



**AIRBANK**<sup>®</sup>  
HSE SOLUTIONS PROVIDER

TAKING CARE OF THE ENVIRONMENT





## COMPANY PROFILE

■ THE COMPANY .....	page 04
■ SAFETY POINTS .....	page 16

## ABSORPTION PRODUCTS



1 ABSORBENTS FOR OILS AND HYDROCARBONS ON SOIL OR WATER .....	page 20
2 ABSORBENTS FOR ALL LIQUIDS .....	page 31
3 ABSORBENTS FOR CORROSIVE, CAUSTIC AND TOXIC LIQUIDS.....	page 47
4 SPECIAL ABSORBENTS .....	page 52

## EMERGENCY SPILL KITS FOR INDUSTRY AND TRANSPORT



KITS FOR OIL AND HYDROCARBON SPILLS .....	page 58
KITS FOR ALL LIQUID SPILLS.....	page 66
5 KITS FOR SPILLS OF CORROSIVE, CAUSTIC AND TOXIC LIQUIDS.....	page 72
KIT FOR SPILLS OF SPECIAL LIQUIDS.....	page 78
EYE WASH STATIONS .....	page 84

## PRODUCTS FOR LAND AND WATER SPILLS



CONTAINMENT BOOMS FOR SEA SPILLS .....	page 88
6 FLOOD BOOMS.....	page 92
OIL SKIMMERS.....	page 95
7 SAFETY GUARDS FOR DRAINS AND GRIDS.....	page 99

## CLEANING PRODUCTS



8 DEPOLLUTANTS AND DETERGENTS FOR INDUSTRIAL CLEANING .....	page 104
9 BIODEGRADABLE AND BIOLOGICAL PRODUCTS .....	page 114

## CONTAINMENT PRODUCTS



- 10 SMALL AND MEDIUM STORAGE SOLUTIONS .....page 122
- 11 LARGE STORAGE SOLUTIONS.....page 165
- 12 LIQUIDS CONTAINMENT AND TRANSPORT .....page 176
- 13 SOLIDS CONTAINMENT AND TRANSPORT .....page 229

## PRODUCTS FOR LOGISTICS AND HANDLING



- 14 LOGISTICS AND DRUM AND CARGO PALLET HANDLING EQUIPMENT .....page 264

## PRODUCTS FOR EMERGENCIES



- 15 EMERGENCY AND CIVIL PROTECTION EQUIPMENT .....page 282
- 16 SPECIAL EQUIPMENT .....page 287

## PRODUCTS FOR SAFETY AND MAINTENANCE



- 17 PROTECTIVE COATINGS FOR INDOOR/OUTDOOR SURFACES .....page 292
- ANCHORING SYSTEMS .....page 301
- 18 LABEL PRINTERS.....page 303
- SAFETY SIGNAGE.....page 305

## PRODUCTS FOR STORAGE AND TRANSPORT OF LITHIUM BATTERIES



- 19 PRODUCTS FOR STORAGE AND TRANSPORT OF LITHIUM BATTERIES .....page 308



## TAKING CARE OF THE ENVIRONMENT

*Airbank is the Italian leader in **environmental protection** and **industrial safety**.*

*For over 20 years, it has offered specialist advice to companies and public bodies, and provides products and solutions for managing **HSE aspects** (Health, Safety, Environment).*

*Airbank - which has always been synonymous with high quality standards - can boast the achievement of **UNI EN ISO 9001:2015** and **UNI CEI 11352:2014** certifications.*







**2,000+** LISTINGS



**5,000+** CUSTOMERS



**1,000+** SPECIAL PROJECTS



**4,800+** SURVEYS AT THE CUSTOMER'S PREMISES



**107+** PROVINCES SERVED



**15,000+** CATALOGUES DISTRIBUTED EVERY YEAR



**21+** SAFETY POINTS



**100+** TECHNICAL-COMMERCIAL TRAINING



**m<sup>2</sup> 6,000+** OFFICES AND WAREHOUSES



**10,000+** PHONE CONSULTATIONS/YEAR



Airbank has always been convinced that the preservation of the environment is strictly connected to human well-being. To this end, during 2009, we added a photovoltaic system to our plant, capable of producing over 100,000 KW/h of renewable power per year, with zero impact on the environment.

This important investment has prevented, up to now, the emission of 750,000 kg of CO<sub>2</sub> in the atmosphere, equal to 1800 trees planted, and resulting in Airbank's independence from an energetic point of view.

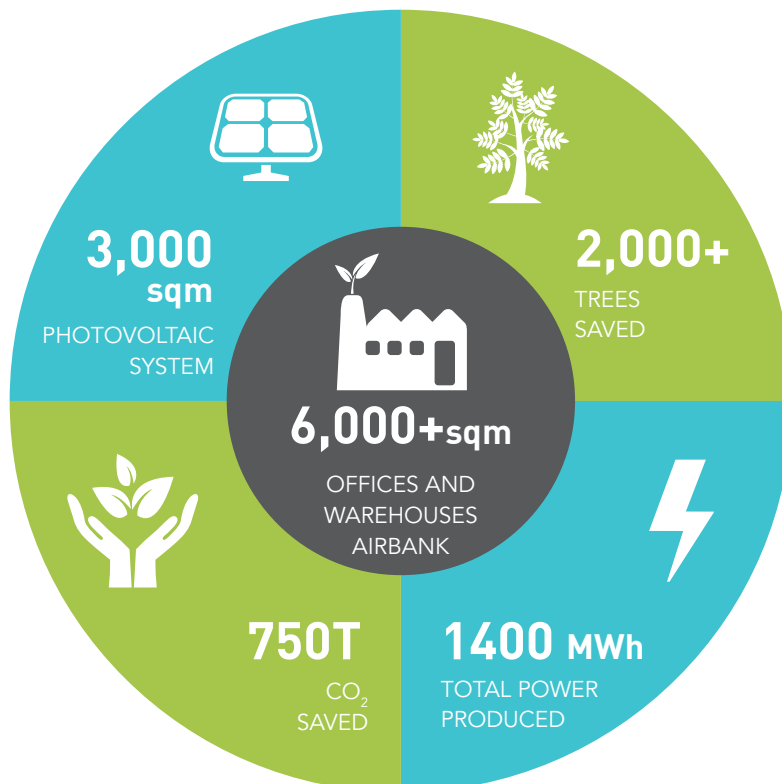





Since 2010, AIRBANK has been a partner of Yamaha Motor Racing, the company which manages Yamaha's MotoGP arm, providing consultancy and supplying products to maintain the ISO 14001 environmental certification which was obtained together in 2010.

“For some years, Yamaha Motor Racing has been involved in a project as ambitious as it is stimulating, whose objective is improving the working conditions of its staff in terms of health and safety and environmental aspects, both in Gernodi Lesmo, headquarters of the Yamaha Factory Racing MotoGP Team, and in the various circuits of the world MotoGP championship. In 2010 we reached the first main objective: ISO 14001 certification. Having reached this first important goal, we are now committed to maintaining an environmental management system which is effective and integrated with the health and safety system. The whole project is in line with Yamaha Motor's CSR (Corporate Social Responsibility)

program, which will be further developed by extending the concept of “sustainability” to all company activities and processes.

We are also particularly committed to a process of sharing experiences and results with the key players of the MotoGP Championship, in other words the Grand Prix promoters, the circuits, the Team Associations (IRTA) and, above all, Dorna, the company which organizes and manages the Championship, with the aim of spreading the concepts of environmental, social and economic sustainability. All this is done with the hope that our motivation and results can also “infect” the public through effective messages and leading by example.

The assistance and consultancy of our partners has been essential throughout the whole process, and above all continues to be crucial during phase 2. We are proud to continue on this path with Airbank, a Yamaha Motor Racing Official Partner, whose products and services will allow us to further improve our company processes and working environment.

Yamaha Motor Racing General Manager



On the back of its experience in the environmental protection and industrial safety sector, Airbank is now ready to take on a leading role in the energy efficiency field.

Thanks to our accreditation as an Energy Saving Company (ESCo) and to the related UNI CEI 11352:2014 compliance certificate, the company will be able to offer our customers the possibility to transform the energy savings obtained through works to improve the energy efficiency of buildings or systems into Energy Efficiency Certificates (white certificates) and follow the whole management of the process, from presentation of the project to the national grid operator GSE up to the sale of the EECs obtained.

In this way, our customers' bill will be cheaper, and they will obtain benefits from the EECs (White Certificates).

The EEC system, apart from giving benefits to the final users, has also positive effects on the environment in terms of prevented emissions: a certificate is equal to a tonne of oil equivalent (TOE) saved.

In view of the new corporate Visions and Missions, Airbank is searching for qualified partners to create a highly professional network, with the aim of supplying the best solutions to its customers in terms of service quality, efficacy, timing, costs and return on investment.







Airbank makes available its certified skills to the Partner organization, as well as the possibility of:

- Negotiating the EECs directly with the GSE and GME
- Carry out the energy audits according to Legislative Decree 102/2014
- Design and implement integrated solutions
- Define the investment criteria by drafting EPC contracts (Energy Performance Contract)

In this way, the partner organization can offer an all-round project management to its customer, with high-quality, efficient and rapid contents at advantageous conditions.

Airbank offers technical and legal training in energy management, efficiency analysis and energy certification.

Furthermore, Airbank offers seminars, workshops and a customer newsletter with the latest regulations.





Airbank, through its research and development department, is constantly in search of innovative emergency and HSE (Health Safety Environment) management solutions, in multiple industrial sectors.



Special products on customer request for the management and resolution of environmental and safety crises.



Products developed by our Team to meet the specific needs of our customers.



Products resulting from partnerships with leading international companies in the antipollution field, of which Airbank is a retailer for Italy.



Biodegradable products with a low environmental impact. These are designed for ISO 14001 or EMAS-certified companies.



Accidental spill kits, completely customisable according to customer requirements, and for which refills are available.



Signs supplied free of charge with the product or kit purchased, which help prevent the risk of potential spills or indicate the location of the anti-spill kit within the work areas.



Integrity ring to be extracted when opening the kit to indicate its use and the consequent need for replenishment, so that each kit is always provided with each component.



### AIRBANK BRANDS



### AIRBANK EXCLUSIVES





### ANTI-POLLUTION CONSULTANCY AND TECHNICAL INSPECTIONS

Environmental consultancy service for environmental protection solutions, technical and regulatory consultancy and implementation of technical and product documentation pursuant to EC and HARMONIZED DIRECTIVES; technical inspections aimed at training company personnel by thorough theoretical education and practical experience with use of the environmental protection products.



### IMPLEMENTATION OF MANAGEMENT SYSTEMS

- Environmental Management Systems (E.M.S.).
- Worker Health and Safety Management Systems.
- Energy management systems.



### CONSTANT SUPPORT

Airbank provides a Technical/Commercial Area Manager for support in your customers' companies, aimed at offering advice, training, and practical demonstrations on the use, efficiency / effectiveness of the products.

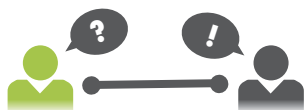

### DEDICATED KEY ACCOUNT

Airbank dedicates a Technical/Commercial figure, to follow every HSE need of your company, day by day, also with the support of our technical department, offering advice, training, and practical demonstrations on the use, efficiency / effectiveness of the products.



### CUSTOMER SERVICE

Assistance, support and supply of products for emergency spill management, thanks to a huge warehouse stock and immediate telephone consultancy to help you choose the right product in a crisis and show you how to use it. Telephone support for environmental emergencies 24/7/365.



### ACADEMY

We organize customised environmental training courses and webinars at your companies, in our Airbank headquarters or online.



### SAFETY DAY

Airbank organizes the "Safety Day" to raise awareness and involve stakeholders, managers, employees and suppliers on the main HSE issues. The event will take place in person or online.



The Airbank Environmental Engineers Team is at your disposal for a FREE CHECK UP at your company, in order to analyse processes and any environmental issues and, following a report, offer you the most appropriate solutions to implement in your company, considering all the regulations in force.



### 01. INSPECTION

*Airbank's Team comes to your company and, with help from the HSE and/or RSPP, carries out a visual and documentary inspection of environmental procedures and issues.*



### 02. ANALYSIS

*With the information gathered during the inspection, Airbank's Team begins a detailed analysis of the risks and problems encountered.*



### 03. DESIGN

*The problems and risks encountered are grouped, and then the relevant anti-pollution solutions are identified.*



### 04. REPORT AND SOLUTION

*At the end of the inspection, the engineer draws up a report showing, for each critical issue detected, a possible start for improvement and the related solution.*

**ASK FOR A CHECK-UP  
OF YOUR COMPANY**







We organize customised environmental training courses and at your companies, in our Airbank headquarters or online.

### RECIPIENTS

- Health and Safety managers and representatives
- Qualified operators
- Company safety teams
- Consultants
- Employers

### PLUS

- The course leaders are highly specialized experts in the sector as well as being experienced trainers.
- Course contents are made topical for your company and its individual requirements: problem finding and operational identification of solutions.
- Possibility to tailor courses to the specific needs of the participants.
- Use of innovative and effective products.

### OUR COURSES

- Emergency spill response procedures and regulatory updates in the environmental safety field
- ISO14001 and Ecological Footprint
- Waste and hazardous substance management
- Management of corporate environmental and industrial safety issues



### E-LEARNING

*you can participate in Airbank courses on environmental safety in e-learning mode! You just need a computer or tablet connected to the Internet to finally stay up to date on first response procedures, in addition to the new regulations in the field of environmental safety.*

**DISCOVER  
AIRBANK TRAINING**



### SECTOR REGULATORY CATALOGUES

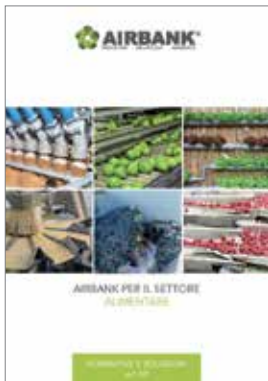

**FOOD**



**CHEMICAL/PHARMA**



**ENGINEERING**



**PUBLIC ADMINISTRATION**



**PORT/NAVAL**



**TRANSPORT**



**WASTE MANAGEMENT**

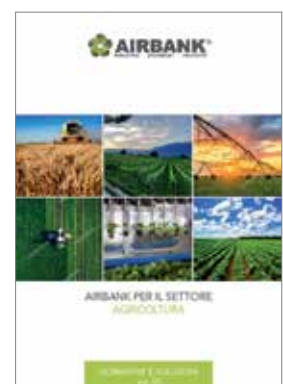

**AGRICULTURE**

**DOWNLOAD THE  
FIELD BROCHURES**



### TUTORIALS AND COMPARATIVE VIDEOS

Airbank has created several videos to support its customers: numerous tutorials to show the possible use of the main products for containment, absorption, cleansing and protection purposes, and comparative videos that prove the pros of our products in practice, by comparing them to commonly adopted solutions.



Uni-safe



Absorbent pad comparison



Absorbent powder comparison

**WATCH THE  
VIDEO GALLERY**



*Airbank launched its first network of "Safety Points" to ensure capillary assistance, support and supply of products for emergency spill management over the entire Italian territory.*



## ENVIRONMENTAL EMERGENCY

As of today, your company has a partner in case of **environmental emergencies**: whether it is flammable liquids, spills of oils into water, or battery chemicals. **Airbank's Safety Points** are at your side to guide you in the application of the most suitable procedures and provide you with **emergency response products**.



## SERVICES

Not only products, but also **services**: **Airbank's Safety Points** offer advice for timely intervention management, **video tutorials** to make the best use of our products and an **environmental check-up service** to prevent future spills.







**SAFETY  
POINT**

Airbank's Safety Points **are** the reference in Italy for the **extraordinary supply of products for managing emergencies** on land and in water, for any type of company present in neighbouring territories.

## SAFETY POINTS IN ITALY

-  ANCONA
-  BARI
-  BELLUNO
-  BRESCIA
-  CAGLIARI
-  FLORENCE
-  LATINA
-  MANTOVA
-  MONFALCONE
-  NAPLES
-  PERUGIA
-  **PIACENZA**
-  POTENZA
-  RAVENNA
-  SONDRIO
-  TERAMO
-  TORINO PINEROLO
-  TORINO SETTIMO
-  TRAPANI
-  VARESE
-  VICENZA



**LOOK FOR AIRBANK'S  
SAFETY POINT CLOSEST TO YOU**







# ABSORPTION PRODUCTS

1	ABSORBENTS FOR OILS AND HYDROCARBONS ON SOIL OR WATER .....	page 20
2	ABSORBENTS FOR ALL LIQUIDS .....	page 31
3	ABSORBENTS FOR CORROSIVE, CAUSTIC AND TOXIC LIQUIDS.....	page 47
4	SPECIAL ABSORBENTS .....	page 52



# OKO-PUR

 AIRBANK EXCLUSIVE



### Full saturation oil binder in powder and granulate form

Specially designed to absorb oil, grease, petrol, diesel oil, paints and chemicals on the floor of working areas. Being an absorbent powder, OKO-PUR can be used to absorb the spreading of oil and hydrocarbon spills on the ground or in artificial and confined water bodies such as tanks and reservoirs. IS a user-friendly product (to be used like sawdust) with unique features: just think that OKO-PUR can even absorb oil in water, forming large, easily retrievable lumps. In this way OKO-PUR reduces the oil content in the polluted water by more than 95%. OKO PUR is available both as a powder and as granules. It boasts enormous absorbency: a 6.8 kg bag can absorb 30-80 kg of liquid. OKO-PUR is the only absorbent which has a positive effect on the environment: producing 1 kg of OKO-PUR prevents the emission of 250 Kg of CO<sup>2</sup> into the atmosphere, as the polyurethane it is composed of comes from the insulation of discarded refrigerators. OKO-PUR saves both raw materials and the energy required to produce them, contributing to protecting the environment.

### STRONG POINTS

- Water repellent
- Absorption speed
- It doesn't stick to shoes or vehicle wheels
- Does not produce sludge or solidify
- Saves half the work
- Water repellent also in the event of rain
- Significantly reduced disposal costs
- Unchanged road adherence (MPA NRW)

### APPLICATIONS

- Roads
- Motorways
- Industry
- Reclamation
- Workshops
- Spare parts dealers

### FEATURES

- The most widely used absorbent in Europe for environmental reclamation
- It is water repellent
- It separates oil from water, leaving it clean and up to 95% decontaminated
- It holds oil even when squeezed
- OKO PUR floats on water even when saturated
- It does not contain aggressive chemicals
- Thanks to its minimal weight and absorbency you can save up to 2/3 of disposal costs
- It can be disposed of at waste tips without problems
- It replaces sawdust, wipes and detergents
- OKO-PUR is certificated by the German hygiene office and MPA-NRW materials control board
- OKO-PUR can absorb up to 10 times its own weight, depending on the product being dealt with

CODE	DESCRIPTION	PACKAGING	BOX AVERAGE ABSORPTION
401 000 001	Powder absorbent OKO PUR PLUS • 6.8 kg bag	-	34 L
401 000 002	Powder absorbent OKO PUR PLUS • 204 kg box	30 bags x 6.8 kg	1012 L
401 000 003	Granules absorbent OKO PUR KOMPACT • 16 kg bag	-	21 L
401 000 004	Granules absorbent OKO PUR KOMPACT • 480 kg box	30 bags x 16 kg	633 L
401 004 575	Powder absorbent OKO-PUR PLUS • 13 L bucket	-	9 L
401 004 576	Granules absorbent OKO-PUR KOMPACT • 13 L bucket	-	5.5 L

Average absorption derived from laboratory tests in compliance with UNI CEN/TS 15366/2010

Pictures indicated in this catalogue are representative and not binding for the supplier in terms of layout and colours. They may be subject to changes by the supplier without prior notice.

### Absorption test with OKO-PUR powder in oil polluted water



### Absorption test with OKO-PUR powder on the floor



### IIIR APPROVED FOR ROAD SAFETY:

OKO PUR, both in powder and granulate form, has been certified as an excellent absorbent for heavily trafficked roads. The German Home Office (BMI) in their report "Removal of oil residue from heavily trafficked roads" specifies that after making use of absorbents for the elimination of

the polluting substance and the subsequent clean-up with a water-detergent mixture, the road surface must still provide good grip, in any case not less than 80% of the original value, especially if it is damp. In carrying out the obligation laid down by the Italian Home Office,

the Italian regions specify that only approved absorbents with MPA-III R certification can be used on road surfaces. Each OKO-PUR bag carries the corresponding approval label.



WATCH THE VIDEO



Pictures indicated in this catalogue are representative and not binding for the supplier in terms of layout and colours. They may be subject to changes by the supplier without prior notice.

### OIL FREE



#### Full saturation oil binder in powder and granulate form

OIL FREE can be used for absorbing oil and hydrocarbon spills on the ground. It is a user-friendly product (to be used like sawdust). OIL FREE is water-repellent and as such does not absorb water. This gives OIL FREE an impressive absorption capacity, and has impressive yield when used on oils and hydrocarbons, offering significant savings in the procurement and disposal stages.

OIL FREE is available in two formats: powder and granules. The powder is recommended for indoor environments, while the granules are more suited to outdoor spills; both versions are manufactured from recycled polyurethane.

The product complies with the technical specification UNI CEN/TS 15366/2010, issued by Italian standardisation body UNI, for granular products for the absorption of hydrocarbons, mineral oils and similar products on road surfaces and in transit areas.



#### STRONG POINTS

- It is water repellent
- It holds oil even when squeezed
- It floats on water even when saturated
- It does not contain aggressive chemicals
- It replaces sawdust, wipes and detergents
- Complies with UNI CEN/TS 15366/2010

#### APPLICATIONS

- Roads/Highways
- Industry
- Reclamation
- Workshops

#### FEATURES

- Recycled polyurethane foam
- Physical appearance: powder or granules
- Colour: grey
- Odour: none
- pH (at 25°C): 7.4

CODE	DESCRIPTION	PACKAGING	BOX AVERAGE ABSORPTION
401 004 156	Powder absorbent OIL FREE • 50 L bag	-	42 L
401 004 157	Powder absorbent OIL FREE • 1500 L box	30 bags x 50 L	1260 L
401 004 158	Granules absorbent OIL FREE • 50 L bag	-	28 L
401 004 159	Granules absorbent OIL FREE • 1500 L box	30 bags x 50 L	840 L
401 004 577	Powder absorbent OIL FREE • 13 L bucket	-	11 L
401 004 578	Granules absorbent OIL FREE • 13 L bucket	-	7.5 L

Average absorption derived from laboratory tests in compliance with UNI CEN/TS 15366/2010



WATCH THE VIDEO



Pictures indicated in this catalogue are representative and not binding for the supplier in terms of layout and colours. They may be subject to changes by the supplier without prior notice.



# NATURAL CORK SORB



### Granular absorbent certified for liquids such as hydrocarbons, mineral oils and similar liquids

Product made from natural cork, treated to absorb liquid pollutants such as hydrocarbons, mineral oils and similar liquids on roads, paving and other solid surfaces. The granular cork does not rot or decay and has a virtually unlimited shelf life in dry environments. The product as-is can be disposed of as solid urban waste. Disposal must comply with applicable legislation, taking into account the absorbed liquid inasmuch as the product contaminated by the liquid will present the same hazards as the absorbed product.



### STRONG POINTS

- UNI CEN TS 15366/2010 certified
- Water repellent
- Biodegradable
- Non-flammable
- Absorbs pollutant liquids such as hydrocarbons, mineral oils and similar liquids

### APPLICATIONS

- Roads
- Flooring
- Solid surfaces in general

### FEATURES

- Granule diameter up to approx. 1.5 mm diameter; s.w. 0.18 - 0.30 approx.
- Inflammable, and does not produce harmful powders. Testing has highlighted an impressive ability to make flooring and roads safe thanks to its high coefficient of friction.
- The product complies with the technical specification UNI CEN/TS 15366/2010, issued by Italian standardisation body UNI, for granular products for the absorption of hydrocarbons, mineral oils and similar products on road surfaces and in transit areas.

CODE	DESCRIPTION	PACKAGING	BOX AVERAGE ABSORPTION
401 003 776	NATURAL CORK SORB granular absorbent • 10 kg bag	-	16 L
401 003 777	NATURAL CORK SORB granular absorbent • 300 kg box	30 bags x 10 kg	480 L
401 004 581	Granular absorbent NATURAL CORK SORB • 13 L bucket	-	4 L

Average absorption derived from laboratory tests in compliance with UNI CEN/TS 15366/2010



WATCH THE VIDEO



Pictures indicated in this catalogue are representative and not binding for the supplier in terms of layout and colours. They may be subject to changes by the supplier without prior notice.

### "OIL ONLY ULTRA" SERIES ABSORBENTS



Absorbents made of 100% polypropylene (PP) fibre to clean up large spills and leakages of oil, hydrocarbons, paints and solvents, both on the ground and in water. The "Oil Only Ultra" range of absorbents is authorised by the Italian Ministry of the Environment for use at sea. The absorbers of this series combines a great absorption, low costs and can be reused until fully saturated.



BAG

PADS

BOOM

#### STRONG POINTS

- They do not absorb water - water-repellent
- High absorption capacity
- Reduced disposal costs
- Save up to 30%.

CODE	DESCRIPTION	BOX AVERAGE ABSORPTION
401 000 053	Oil Only Ultra absorbent pad • 41 x 46 cm • 100 pieces/box	146 L
401 000 054	Oil Only Ultra absorbent pad • 41 x 46 cm • 200 pieces/box	151 L
401 000 055	Oil Only Ultra absorbent pad • 81 x 91 cm • 50 pieces/box 	264 L



CODE	DESCRIPTION	BOX AVERAGE ABSORPTION
401 000 056	Oil Only Ultra absorbent pillow • 25 x 25 cm • 20 pieces/box	57 L
401 000 057	Oil Only Ultra absorbent pillow • 46 x 46 cm • 10 pieces/box	78 L



Pictures indicated in this catalogue are representative and not binding for the supplier in terms of layout and colours. They may be subject to changes by the supplier without prior notice.

CODE	DESCRIPTION	BOX AVERAGE ABSORPTION
401 000 060	Oil Only Ultra absorbent sock • Ø 7.6 x 122 cm • 15 pieces/box	85 L
401 000 061	Oil Only Ultra absorbent sock • Ø 7.6 x 122 cm • 40 pieces/box	220 L
401 000 062	Oil Only Ultra absorbent sock • Ø 7.6 x 305 cm • 6 pieces/box	84 L
401 000 063	Oil Only Ultra absorbent sock • Ø 13 x 300 cm • 4 pieces/box*	135 L
401 000 064	Oil Only Ultra absorbent sock • Ø 20 x 300 cm • 4 pieces/box*	269 L

\* Equipped with clips for linking



CODE	DESCRIPTION	BOX AVERAGE ABSORPTION
401 000 065	Oil Only Ultra absorbent roll • 81 cm x 46 m • 1 piece/box	292 L
401 000 066	Oil Only Ultra absorbent roll • 41 cm x 46 m • 2 pcs/box	292 L



CODE	DESCRIPTION	BOX AVERAGE ABSORPTION
401 000 067	Oil Only Ultra drum top cover • Ø 56 cm • 25 pieces/box 	50 L
401 000 058	Oil Only Ultra absorbent boom • Ø 20 x 41 cm • 10 pieces/box	46 L
401 000 059	Oil Only Ultra skimmer bag • 41 x 51 x 12 cm • 10 pieces/box	163 L



DRUM COVERS



BOOM



BAG

 = Perforated  
Faster absorption

 = Pre-cut  
Greater versatility of use

Pictures indicated in this catalogue are representative and not binding for the supplier in terms of layout and colours. They may be subject to changes by the supplier without prior notice.



### "OIL ONLY STRONG" SERIES ABSORBENTS



Absorbents made of 100% polypropylene fibre to clean up large spills and leakages of oil, hydrocarbons, paints and solvents, both on the ground and in water, especially when a high mechanical resistance is required, while guaranteeing that no fibres will be released. The "Oil Only Strong" range of absorbents is authorised by the Italian Ministry of the Environment for use at sea. The absorbents of this series guarantee the widest choice of sizes, the best resistance to abrasion and a high absorption rate. They are reusable up to complete saturation.



#### STRONG POINTS

- They do not absorb water - water-repellent
- High mechanical resistance
- They do not release fibres
- Fast absorption
- Wide range of sizes

CODE	DESCRIPTION	BOX AVERAGE ABSORPTION
401 000 007	Oil Only Strong absorbent pad • 30 x 30 cm • 200 pieces/box 	71 L
401 000 008	Oil Only Strong absorbent pad • 41 x 51 cm • 100 pieces/box  	114 L
401 000 034	Oil Only Strong absorbent pad • 41 x 51 cm • 100 pieces/box	136 L
401 000 009	Oil Only Strong absorbent pad • 41 x 51 cm • 200 pieces/box  	166 L
401 000 036	Oil Only Strong absorbent pad • 41 x 51 cm • 200 pieces/box	221 L
401 000 010	Oil Only Strong absorbent pad • 84 x 100 cm • 50 pieces/box 	230 L



CODE	DESCRIPTION	BOX AVERAGE ABSORPTION
401 000 011	Oil Only Strong absorbent pillow • 22 x 24 cm • 32 pieces/box	53 L
401 000 012	Oil Only Strong absorbent pillow • 43 x 48 cm • 16 pieces/box	105 L



CODE	DESCRIPTION	BOX AVERAGE ABSORPTION
401 000 013	Oil Only Strong absorbent boom • Ø 13 x 45 cm • 10 pieces/box	46 L
401 000 014	Oil Only Strong absorbent boom in a nylon bag with hanging loop Ø 36 x 64 cm • 10 pieces/box	197 L



Pictures indicated in this catalogue are representative and not binding for the supplier in terms of layout and colours. They may be subject to changes by the supplier without prior notice.

CODE	DESCRIPTION	BOX AVERAGE ABSORPTION
401 000 015	Oil Only Strong absorbent sock • Ø 7.6 x 122 cm • 12 pieces/box	43 L
401 000 016	Oil Only Strong absorbent sock • Ø 7.6 x 122 cm • 30 pieces/box	106 L
401 000 017	Oil Only Strong absorbent sock • Ø 7.6 x 244 cm • 6 pieces/box	43 L
401 000 018	Oil Only Strong absorbent sock • Ø 7.6 x 366 cm • 4 pieces/box	43 L
401 000 019*	Oil Only Strong absorbent sock • Ø 13 x 300 cm • 4 pieces/box	119 L
401 000 038	Oil Only Strong absorbent sock • Ø 13 x 300 cm • 4 pieces/box	155 L
401 000 020*	Oil Only Strong absorbent sock • Ø 13 x 500 cm • 2 pieces/box	98 L
401 000 040	Oil Only Strong absorbent sock • Ø 20 x 300 cm • 4 pieces/box	280 L
401 000 021*	Oil Only Strong absorbent sock • Ø 20 x 300 cm • 4 pieces/box	316 L
401 000 022*	Oil Only Strong absorbent sock • Ø 20 x 1000 cm • 1 piece/box	274 L
401 000 023*	Oil Only Strong absorbent sock • Ø 20 x 500 cm • 2 pieces/box	274 L
401 000 024	Oil Only Strong absorbent sock • Ø 7.6 x 1700 cm • 1 piece/box	59 L

\* Equipped with clips for linking





CODE	DESCRIPTION	BOX AVERAGE ABSORPTION
401 000 026	Oil Only Strong absorbent roll • 96 cm x 44 m • 1 piece/box	231 L
401 000 042	Oil Only Strong absorbent roll • 96 cm x 44 m • 1 piece/box	274 L
401 000 027	Oil Only Strong absorbent roll • 48 cm x 44 m • 2 pieces/box	231 L
401 000 044	Oil Only Strong absorbent roll • 48 cm x 44 m • 2 pieces/box	274 L
401 000 028	Oil Only Strong absorbent roll • 38 cm x 46 m • 1 piece/box	94 L
401 000 029	Oil Only Strong absorbent roll (pre-cut every 23 cm and in the centre) • 38 cm x 46 m, 1 piece/box	94 L
401 000 030	Oil Only Strong absorbent roll • 76 cm x 46 m • 1 piece/box	187 L
401 000 031	Oil Only Strong absorbent roll (pre-cut every 38 cm and in the centre) • 76 cm x 46 m, 1 piece/box	187 L
401 003 538	Oil Only Strong mini absorbent roll • 19 cm x 15 m (60 sheets) • 1 piece/box	15 L



CODE	DESCRIPTION	BOX AVERAGE ABSORPTION
401 000 032	Oil Only Strong pre-cut drum top covers • Ø 56 cm • 25 pieces/box	26 L
401 000 033	Oil Only Strong drip tray (tray size 37 x 31 cm) 5 trays + 40 pillows 23 x 23 cm	65 L



 = Perforated  
Faster absorption

 = Pre-cut  
Greater versatility of use

Pictures indicated in this catalogue are representative and not binding for the supplier in terms of layout and colours. They may be subject to changes by the supplier without prior notice.

## "OIL ONLY MINERAL" SERIES ABSORBENTS

Absorbents made from a revolutionary natural mineral fibre, with nano-reinforcement – 100% eco friendly. Can be used for oil and hydrocarbon spills even in water, as it is completely water repellent. Their impressive absorption provides significant disposal and initial procurement savings.



### STRONG POINTS

- *High absorption capacity: 1 g of mineral fibre absorbs up to 50g of oil compared to 14 g of traditional absorbents (average values)*
- *High speed of absorption: absorbs 99% of the spill in the first 15 minutes*
- *Recovery potential: squeezing out the absorbent allows recovery of the spilled oil*
- *Non-flammable*



CODE	DESCRIPTION	BOX AVERAGE ABSORPTION
401 004 007	Oil Only Mineral absorbent sock • ø 8 x 120 cm • 20 pieces/box	120 L
401 004 931	Oil Only Mineral absorbent pillows • 45 x 40 cm • 20 pieces/box	220 L

The 2-in-1 socks contain absorbent pillows and can thus be used like traditional socks to form barriers, or else opened and the pillows inside them used individually.



CODE	DESCRIPTION	BOX AVERAGE ABSORPTION
401 004 004	2-in-1 Oil Only Mineral absorbent sock 8 pillows • 8 pieces/box	160 L



WATCH THE VIDEO











### “OIL ONLY HEAVY TRAFFIC IMPERMEABLE” SERIES ABSORBENTS

Reinforced absorbents with high mechanical resistance (suitable for forklift trucks and heavy vehicles). Polyethylene (PE) (120 micron) backing for perfect insulation from the ground. Used in Europe for protection of stations, stretched between the tracks and the sides.

CODE	DESCRIPTION	BOX AVERAGE ABSORPTION
401 000 046	Oil Only Heavy Traffic Impermeable absorbent pad • 74 x 74 cm • 30 pieces/box 	95 L
401 000 068	Oil Only Heavy Traffic Impermeable absorbent roll • 48 cm x 24.4 m • 2 pieces/box 	230 L
401 000 070	Oil Only Heavy Traffic Impermeable absorbent roll • 147 cm x 24.4 m • 1 piece/box 	352 L

 = Perforated  
Faster absorption



### “OIL ONLY ANTI-STATIC” SERIES ABSORBENTS

Specific absorbents for oils and hydrocarbons designed for those areas where static electricity can cause problems. Ideal for workshops and factories where there are flammable liquid storages.

CODE	DESCRIPTION	BOX AVERAGE ABSORPTION
401 003 404	Oil Only Anti-static absorbent pad • 38 x 48 cm • 50 pieces/box	30 L
401 003 589	Oil Only Anti-static absorbent roll • 76 cm x 46 m • 1 piece/box	167 L



Pictures indicated in this catalogue are representative and not binding for the supplier in terms of layout and colours. They may be subject to changes by the supplier without prior notice.



### OIL FILTER FABRIC



Oil filter fabric allows large volumes of water to pass through while absorbing petroleum products, vegetable oils and animal fats. Great for use in oil-water separators, stormwater and wastewater filtration systems and water “refinement” applications.

When used as a filter medium, water passes freely, while absorption of hydrocarbons begins on contact with the material.

It works well as a fibrous supporting matrix for other water conditioning materials such as selective zeolites and activated carbon.

Approximately 85-90 % of absorbed material can be reclaimed from the filter material when compressed. It is environmentally harmless and user-friendly.

When incinerated, it produces minimal residue or ash.

CODE	DESCRIPTION	THICKNESS
401 002 562	Oil filter fabric roll • 1.5 x 1 m • 1 piece/box	1.5 mm
401 002 278	Oil filter fabric roll • 1.5 x 76 m • 1 piece/box	1.5 mm

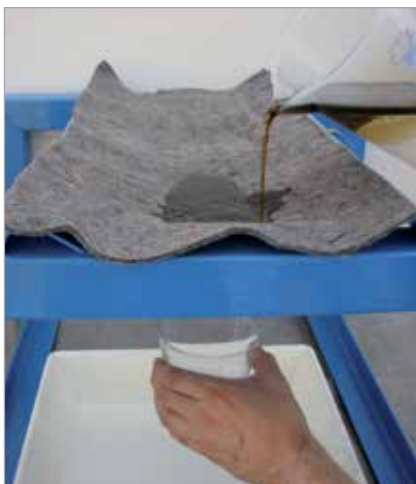

WATCH THE VIDEO



# FIRESORB



### Fireproof plant-based absorbent for all liquids

FIRESORB is a fireproof absorbent composed of spruce granules treated at 800°C which are able to absorb all types of liquids, oils, solvents, inks, non-corrosive chemical products and fats. It can be used in complete safety on all floor surfaces, thanks to its non-slip properties, and does not form a sludge on contact with water or oil. It rapidly absorbs liquids and is easily collected with a vacuum or broom. Disposal to be performed according to applicable regulations for the absorbed liquid.

### STRONG POINTS

- Absorbent with high heat resistance (fireproof)
- Absorption capacity: approx. 3 times its own weight
- Absorbs all types of dangerous liquid
- Does not form a sludge on contact with water and oil
- Complies with standard UNI CEN/TS 15366:2010 for use on roads
- Easy to use

### APPLICATIONS

- Workshops
- Automotive and aerospace industry
- Garages
- Petrol stations
- Transit areas
- Motorway companies
- Petrochemical industry

### FEATURES

- Absorbency by weight: 250%
- Colour: green
- Non-toxic
- Biodegradable
- 100% plant-based
- Absorbs all types of liquids, oils, solvents, inks, non-corrosive chemical products and fats
- Antislip
- Tested by an accredited laboratory which compares FIRESORB to M1 class fireproof wood panels following flammability and propagation testing
- Granulometry: from 0.5 to 1 mm
- Density: 170 - 180 Kg/m<sup>3</sup>

CODE	DESCRIPTION	PACKAGING	BOX AVERAGE ABSORPTION
402 000 126	FIRESORB plant-based absorbent • Bag 70 L	-	34 L
402 000 071	FIRESORB plant-based absorbent • Box 2520 L	36 x 70 L bags	1224 L
402 000 127	FIRESORB plant-based absorbent • Bag 35 L	-	17 L
402 000 072	FIRESORB plant-based absorbent • Box 2450 L	70 x 35 L bags	1190 L
402 004 579	Plant-base absorbent FIRESORB • 13 L bucket	-	7 L



WATCH THE VIDEO



Pictures indicated in this catalogue are representative and not binding for the supplier in terms of layout and colours. They may be subject to changes by the supplier without prior notice.



# STONE UNIVERSAL SORB



UNIVERSAL MINERAL ABSORBENT

### Mineral absorbent for all liquids

STONE UNIVERSAL SORB is a natural mineral absorbent for oils, solvents, thinners, acids, paints, inks, lubricants, refrigerant lubricants, fats and food products. It absorbs any liquid or semi-liquid product of organic, inorganic, synthetic or natural origin, from absolutely any surface. It surrounds the absorbed substance, keeping it inside the powder particle (silica encapsulation), as the product particles are like cotton wool, with a hollow, reticular absorbent structure which absorbs, holds and does not release the collected substance.

To use the product, just spread it on the ground near to, but not on the spill, surrounding it. Then use a broom with thin, stiff bristles to push the powder over the spill, pressing it lightly with circular movements so as to surround the whole of the spill. The surface will be totally dry, with viscous substances such as paint or hydraulic fluid absorbed from the floor, which will be completely clean without requiring washing.

N.B.: the product must not be used on Mercury, as it cannot be absorbed, or on Hydrofluoric acid due to the possible formation of toxic gases on reaction with the absorbent.



UNIVERSAL MINERAL ABSORBENT

### STRONG POINTS

- Powder of 100% mineral origin
- Inflammable, that is it does not burn or feed fires (Reaction to fire class A1)
- It is inert, that is it does not react with any absorbed substance
- It is amorphous and harmless to the environment
- It requires no particular disposal procedure: it is comparable to sand
- It is harmless as it does not damage land or the atmosphere
- It does not contain bacteria or attract insects

### APPLICATIONS

- Industrial sector
- Food sector
- Workshops
- Spare parts dealers

### FEATURES

- Physical appearance: fine powder
- Colour: white
- pH at 3%:  $7 \pm 0.5$
- Density:  $0.08 - 0.26 \text{ g/cm}^3$
- ECO version: density:  $1.12 - 1.15 \text{ g/cm}^3$
- Fire-resistant
- It is lightweight (an economic advantage when disposing of the product, the costs of which are determined by the total weight of the liquid + absorbent)
- Absorption between 3 and 8 times its own weight (80 g of product allows you to absorb 250 g of paint or 600 g of hydrocarbons)

CODE	DESCRIPTION	PACKAGING	BOX AVERAGE ABSORPTION
404 002 787	STONE UNIVERSAL SORB mineral absorbent powder • 5 kg bag	-	37 L
404 002 779	STONE UNIVERSAL SORB mineral absorbent powder • 250 kg box	50 bags x 5 kg	1875 L
404 002 788	STONE UNIVERSAL SORB mineral absorbent powder • 10 kg bag	-	75 L
404 002 780	STONE UNIVERSAL SORB mineral absorbent powder • 300 kg box	30 bags x 10 kg	2250 L
404 003 769	STONE UNIVERSAL SORB ECO mineral absorbent powder • 10 kg bag	-	30 L
404 003 770	STONE UNIVERSAL SORB ECO mineral absorbent powder • 300 kg box	30 bags x 10 kg	900 L
404 004 580	Mineral powder absorbent STONE UNIVERSAL SORB • 13 L bucket	-	11 L

## POWDER COMPARISON

### TESTING METHODS

To carry out the tests, a block of cement was stained with **100 g of waste oil** (one of the most difficult oils to absorb), which was then absorbed with a known quantity of products.

For each test, **the powder used was weighted in a glass, using enough powder to completely absorb the stain.**

The result evaluation has been carried out considering two factors:

- Absorption capacity by weight (quantity in kg of oil absorbed by 1 kg of powder)
- Surface cleaning level

### SEPIOLITE

To absorb the 100 g oil stain, 4 powder glasses were used (600g). The absorption power was 16.7%. At the end of the test, the surface was still soiled and oily.



IN A NUTSHELL	
Oil stain	100 g
Quantity of powder used	4 glasses (600 g)
Absorption power	16.7%
<b>RESULTS</b>	At the end of the test, the surface was still soiled and oily

### STONE UNIVERSAL SORB

With Stone Universal Sorb, 2 glassed of powder were used (70 g): absorption power of 143% (**8.5 times higher than sepiolite's**).



IN A NUTSHELL	
Oil stain	100 g
Quantity of powder used	2 glasses (70 g)
Absorption power	143%
<b>RESULTS</b>	At the end of the test, the surface was perfectly clean and not oily

### DISPOSAL

Hypothesising to purchase and store a quantity of powder necessary to absorb the leakage from a 200 Kg oil drum, I'd have to store:

<b>SEPIOLITE</b>	1200 kg	240 bags x 5 kg
<b>STONE UNIVERSAL SORB</b>	140 kg	28 bags x 5 kg

Hypothesising the absorption of 200 Kg of oil, considering the exhaust product disposal costs (powder used + oil absorbed), which are calculated "by the pound", I'll have to dispose of the following quantities:

<b>SEPIOLITE</b>	1400 Kg	-
<b>STONE UNIVERSAL SORB</b>	340 Kg	cost 4 times lower than SEPIOLITE

WATCH  
THE VIDEO



POWDER  
COMPARATOR.



### STERILSORB



#### Biodegradable plant-based absorbent for food-service and hospital use

STERILSORB is a plant-based absorbent, additive and colouring free, composed of wooden granules thermally treated at 800°C. It boasts very high absorption, is quick to use and absorbs all liquids instantly. It is designed to be spread on the floor following spills of oily or greasy substances, or as a precautionary measure to reduce slipping.

#### STRONG POINTS

- Chemically inert
- Absorption capacity: approx. 3 times its own weight
- Does not form a sludge on contact with water and oil
- Easy to use



### STERILSORB®

PLANT-BASED ABSORBENT  
BIODEGRADABLE

#### APPLICATIONS

- Food industry
- Pharmaceutical industry
- Hospitals
- Restaurants and canteens
- Food shops (butcher, grocer, fishmonger, patisserie, bakery etc.)
- Maintenance of riding facilities and horse boxes
- Makes ideal pet litter

#### FEATURES

- Biodegradable
- Granulometry: from 0.5 to 1 mm
- Retains liquids after absorption
- Density: 140 - 160 Kg/m<sup>3</sup>
- Absorbency by weight: 250%
- Disposal to be performed according to applicable regulations for the absorbed liquid

CODE	DESCRIPTION	PACKAGING	BOX AVERAGE ABSORPTION
402 000 128	STERILSORB biodegradable absorbent • 35 L bag	-	17 L
402 000 073	STERILSORB biodegradable absorbent • 2450 L box	70 x 35 L bags	1225 L



Pictures indicated in this catalogue are representative and not binding for the supplier in terms of layout and colours. They may be subject to changes by the supplier without prior notice.



# OLIV SORB



### Perfumed plant-based absorbent for biological liquids

OLIV SORB is a special absorbent powder for the hygienic removal of various liquid or semi-liquid substances from surfaces; indeed, following clean-up, it allows for the correct disposal of body fluids in places such as schools, nurseries, rest homes, public transport, aircraft etc. OLIV SORB is also suitable for the absorption of non-hazardous odour-causing liquids, such as heating oil. Its natural perfume eliminates foul odours.

### STRONG POINTS

- High absorption capacity
- Stops the spread of foul odours
- Easy to use

### APPLICATIONS

- Fire brigades
- Hospitals and clinics
- Private laboratories
- Veterinary practices
- Food industry

### FEATURES

- Non-toxic
- Does not contain colourings
- Non-flammable

CODE	DESCRIPTION	PACKAGING	BOX AVERAGE ABSORPTION
402 004 243	OLIV SORB universal powder absorbent	300 g bottle	0.14 L
402 004 244	OLIV SORB universal powder absorbent	15 x 300 g bottles	2.10 L

Pictures indicated in this catalogue are representative and not binding for the supplier in terms of layout and colours. They may be subject to changes by the supplier without prior notice.

### “UNIVERSAL ULTRA” SERIES ABSORBENTS

Absorbents made of polypropylene fibre with a surfactant to be used in case of big spills and leaks of any liquid (except for highly-concentrated or toxic chemical fluids). The absorbers of this series combines a great absorption, low costs and can be reused until fully saturated.



#### STRONG POINTS

- It absorb all liquid types
- High absorption capacity
- Reduced disposal costs
- Save up to 30%

CODE	DESCRIPTION	BOX AVERAGE ABSORPTION
402 000 114	Universal Ultra absorbent pad • 41 x 46 cm • 100 pieces/box 	108 L
402 000 115	Universal Ultra absorbent pad • 41 x 46 cm • 200 pieces/box 	133 L





CODE	DESCRIPTION	BOX AVERAGE ABSORPTION
402 000 116	Universal Ultra absorbent pillow • 25 x 25 cm • 20 pieces/box	57 L
402 000 117	Universal Ultra absorbent pillow • 46 x 46 cm • 10 pieces/box	78 L



Pictures indicated in this catalogue are representative and not binding for the supplier in terms of layout and colours. They may be subject to changes by the supplier without prior notice.

CODE	DESCRIPTION	BOX AVERAGE ABSORPTION
402 000 118	Universal Ultra absorbent sock • Ø 7.6 x 122 cm • 15 pieces/box	85 L
402 000 119	Universal Ultra absorbent sock • Ø 7.6 x 122 cm • 40 pieces/box	220 L
402 000 120	Universal Ultra absorbent sock • Ø 7.6 x 305 cm • 6 pieces/box	84 L





CODE	DESCRIPTION	BOX AVERAGE ABSORPTION
402 000 121	Universal Ultra absorbent roll • 81 cm x 46 m • 1 piece/box  	216 L
402 000 122	Universal Ultra absorbent roll • 41 cm x 46 m • 2 pieces/box  	216 L



CODE	DESCRIPTION	BOX AVERAGE ABSORPTION
402 000 123	Universal Ultra Drum Top cover • Ø 56 cm • 25 pieces/box 	50 L



 = Perforated  
Faster absorption

 = Pre-cut  
Greater versatility of use

Pictures indicated in this catalogue are representative and not binding for the supplier in terms of layout and colours. They may be subject to changes by the supplier without prior notice.



### “UNIVERSAL STRONG” SERIES ABSORBENTS

Absorbents made of polypropylene fibre with a surfactant to be used in case of big spills and leaks of any liquid (except for highly-concentrated or toxic chemical fluids), especially when a high mechanical resistance is required, while guaranteeing that no fibres will be released. The absorbents of this series guarantee the widest choice of sizes, the best resistance to abrasion and a high absorption rate. They are reusable up to complete saturation.



#### STRONG POINTS

- It absorb all liquid types
- High mechanical resistance
- They do not release fibres
- Fast absorption
- Wide range of sizes

CODE	DESCRIPTION	BOX AVERAGE ABSORPTION
402 000 094	Universal Strong absorbent pad • 41 x 51 cm • 100 pieces/box	95 L
402 000 074	Universal Strong absorbent pad • 41 x 51 cm • 100 pieces/box	112 L
402 000 096	Universal Strong absorbent pad • 41 x 51 cm • 200 pieces/box	166 L
402 000 075	Universal Strong absorbent pad • 41 x 51 cm • 150 pieces/box	168 L



CODE	DESCRIPTION	BOX AVERAGE ABSORPTION
402 000 076	Universal Strong absorbent pillow • 22 x 24 cm • 32 pieces/box	58 L
402 000 077	Universal Strong absorbent pillow • 43 x 48 cm • 16 pieces/box	106 L



Pictures indicated in this catalogue are representative and not binding for the supplier in terms of layout and colours. They may be subject to changes by the supplier without prior notice.

CODE	DESCRIPTION	BOX AVERAGE ABSORPTION
402 000 078	Universal Strong absorbent sock • Ø 7.6 x 122 cm • 12 pieces/box	45 L
402 000 079	Universal Strong absorbent sock • Ø 7.6 x 122 cm • 30 pieces/box	113 L
402 000 080	Universal Strong absorbent sock • Ø 7.6 x 244 cm • 6 pieces/box	45 L
402 000 081	Universal Strong absorbent sock • Ø 7.6 x 366 cm • 4 pieces/box	45 L
402 000 084	Universal Strong absorbent sock • Ø 7.6 x 1700 cm • 1 piece/box	53 L



CODE	DESCRIPTION	BOX AVERAGE ABSORPTION
402 000 085	Universal Strong absorbent roll • 38 cm x 46 m • 1 piece/box	94 L
402 000 086	Universal Strong absorbent roll (perforated every 23 cm and in the middle) 38 cm x 46 m 1 piece/box	94 L
402 000 087	Universal Strong absorbent roll • 38 cm x 46 m • 1 piece/box	89 L
402 000 100	Universal Strong absorbent roll • 48 cm x 44 m • 2 pieces/box	192 L
402 000 088	Universal Strong absorbent roll • 76 cm x 46 m • 1 piece/box	177 L
402 000 089	Universal Strong absorbent roll • 76 cm x 46 m • 1 piece/box	187 L
402 000 090	Universal Strong absorbent roll (perforated every 38 cm and in the middle) 76 cm x 46 m 1 piece/box	187 L
402 000 098	Universal Strong absorbent roll • 96 cm x 44 m • 1 piece/box	192 L
402 003 757	Universal Strong mini absorbent roll • 19 cm x 15 m (60 sheets) • 1 piece/box	15 L



CODE	DESCRIPTION	BOX AVERAGE ABSORPTION
402 000 092	Universal Strong pre-cut Drum Top cover • Ø 56 cm • 25 pieces/box	26 L
402 000 093	Universal Strong drip tray (tray size 37 x 31 cm) 5 trays + 40 pillows 23 x 23 cm	65 L





**DRUM COVERS**



**DRIP TRAYS**



 = Perforated  
Faster absorption

 = Pre-cut  
Greater versatility of use

# “UNIVERSAL MINERAL” SERIES ABSORBENTS



Absorbents made from a revolutionary natural mineral fibre, with nano-reinforcement – 100% eco friendly. They can be used for spills of oils, hydrocarbons, water-based liquids and, more generally, all types of liquids. Their impressive absorption provides significant disposal and initial procurement savings.



### STRONG POINTS

- *High absorption capacity: 1 g of mineral fibre absorbs up to 50g of oil compared to 14 g of traditional absorbents (average values)*
- *High speed of absorption: absorbs 99% of the spill in the first 15 minutes*
- *Recovery potential: squeezing out the absorbent allows recovery of the spilled oil*
- *Non-flammable*



CODE	DESCRIPTION	BOX AVERAGE ABSORPTION
402 004 005	Universal Mineral absorbent sock • Ø 8 x 120 cm • 20 pieces/box	120 L
402 004 008	Universal Mineral absorbent pillow • 45 x 45 cm • 30 pieces/box	60 L

The 2-in-1 socks contain absorbent pillows and can thus be used like traditional socks to form barriers, or else opened and the pillows inside them used individually.



CODE	DESCRIPTION	BOX AVERAGE ABSORPTION
402 004 002	2-in-1 Universal Mineral absorbent sock 8 pillows • 8 pieces/box	160 L

WATCH  
THE VIDEO







## "UNIVERSAL HEAVY TRAFFIC IMPERMEABLE" SERIES ABSORBENTS

Universal absorbents with high mechanical strength to allow vehicles to drive over them. Strong grip on both sides, one of which is also covered with a thin rubber layer. Perfect for industry, road works, rail and harbours. Can be used as a containment boom and as a mat around machine tools.

CODE	DESCRIPTION	BOX AVERAGE ABSORPTION
402 000 102	Universal Heavy Traffic Impermeable absorbent roll • 91 cm x 15 m • 1 piece/box	46 L
402 000 103	Universal Heavy Traffic Impermeable absorbent roll • 91 cm x 30 m • 1 piece/box	94 L



## "UNIVERSAL DRIVEWAY" SERIES ABSORBENT

Universal "heavy traffic" absorbents; forklifts and heavy vehicles can drive over them without causing damage. These absorbents are equipped with a non-slip surface to increase their stability. Indispensable in areas subject to continuous passage of vehicles and where high mechanical resistance to abrasion and trampling is required. New non-slip model with an adhesive base.

CODE	DESCRIPTION	BOX AVERAGE ABSORPTION
402 000 124	Universal Heavy Traffic Impermeable absorbent roll • 91 cm x 91 m • 1 piece/box	167 L
402 000 105	Universal Heavy Traffic Impermeable absorbent roll • 182 cm x 46 m • 1 piece/box	223 L
402 003 735	Universal Heavy Traffic adhesive, non-slip absorbent roll • 86 cm x 30 m • 1 piece/box	79 L



Pictures indicated in this catalogue are representative and not binding for the supplier in terms of layout and colours. They may be subject to changes by the supplier without prior notice.





### “UNIVERSAL GRAPHITIZED” SERIES ABSORBENTS

Same features as “Universal Strong” absorbents, but they are also covered with a graphitized nylon mesh which also makes them more resistant to foot traffic. Their mechanical resistance also makes them suitable for machine tool maintenance and lubricating liquid absorption.

CODE	DESCRIPTION	BOX AVERAGE ABSORPTION
402 000 107	Universal Graphitized absorbent pad • 41 x 51 cm • 100 pieces/box  	81 L
402 000 109	Universal Graphitized absorbent roll (perforated every 46 cm) 38 cm x 46 m • 1 piece/box  	70 L
402 000 110	Universal Graphitized absorbent roll (perforated every 23 cm and in the centre) 76 cm x 46 m • 1 piece/box  	141 L







 = Perforated  
Faster absorption

 = Pre-cut  
Greater versatility of use





### “UNIVERSAL CAMOUFLAGE PATTERNED” SERIES ABSORBENTS

Unique universal pre-cut and perforated rolls: camouflage pattern. Camouflage pattern hides dirt and reduces premature replacement. Highly resistant, they absorb spills and leaks of any liquid (water, oils, coolants, glues, greases, solvents, acids, bases and detergents). Ideal for foot traffic and machine areas. Abrasion-resistant and highly versatile absorbents which adapt to any workplace.

CODE	DESCRIPTION	BOX AVERAGE ABSORPTION
402 003 534	Universal Camouflage patterned absorbent roll • 41 cm x 46 m • 2 pieces/box  	214 L
402 003 535	Universal Camouflage patterned absorbent roll • 81 cm x 46 m • 1 piece/box  	214 L



 = Perforated  
Faster absorption





 = Pre-cut  
Greater versatility of use

Pictures indicated in this catalogue are representative and not binding for the supplier in terms of layout and colours. They may be subject to changes by the supplier without prior notice.





## “UNIVERSAL HIGH-VISIBILITY” SERIES ABSORBENTS

These high-visibility safety absorbents have improved performance, with absorbent three-ply 100% polypropylene. Specifically manufactured in yellow for safety and for easy separation of hazardous/corrosive waste, they also carry a “CAUTION” symbol to prevent the risk of slipping and falling.

CODE	DESCRIPTION	BOX AVERAGE ABSORPTION
402 003 536	Universal High Visibility absorbent pad • 41 x 46 cm • 100 pieces/box  	86 L
402 003 537	Universal High Visibility absorbent roll • 81 x 91 m • 1 piece/box  	224 L



 = Perforated  
Faster absorption

 = Pre-cut  
Greater versatility of use



## ACCIDENTAL SPILL KIT FOR PUBLIC PLACES

Accidental spill kit designed for public places where immediate action is essential for personal safety. Quicker and more practical to use than standard techniques with a broom/mop and bucket, the practical handle allows it to be easily transported and stored in small spaces.

The pads are suitable for absorbing water- and oil-based liquids, and are made of a tough material resistant to foot traffic and cuts while cleaning in the presence of shards of glass.

Each kit is equipped with 20 absorbent pads per pocket.

CODE	DESCRIPTION	BOX AVERAGE ABSORPTION
402 003 738	Accidental spill kit for public places • 1 portable sign • 40 pads, 36 x 41 cm	15 L
402 003 739	Accidental spill kit for public places refill • 80 pads • 36 x 41 cm • 20 pcs/box	38 L

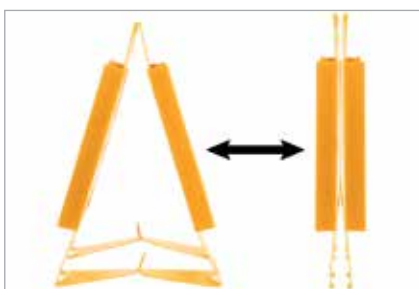





### 2-IN-1 ABSORBENT WIPE DISPENSER

Highly absorbent wipes packaged in a unique 2-in-1 dispenser. The dispenser can be wall- or door-mounted, or else placed directly on the work surface. The product is two-ply and extremely tough and durable; the material is soft and offers superior absorbency compared to paper rolls. Highly absorbent, it is able to absorb oil, fats, water etc. Available for applications in the chemical, medical, food, industrial and machine shop sector.

CODE	DESCRIPTION	PACKAGING	BOX AVERAGE ABSORPTION
402 003 727	Absorbent wipes for food/medical use • 25 x 29 cm • 25 pcs/box	Case of 5 boxes	35 L
402 003 728	Absorbent wipes for chemical use • 25 x 29 cm • 25 pcs/box	Case of 5 boxes	35 L
402 003 729	Absorbent wipes for industrial/engineering use • 25 x 29 cm • 25 pcs/box	Case of 5 boxes	35 L



402 003 727



402 003 728

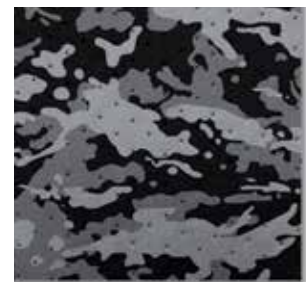

402 003 729

### GRAB & GO ABSORBENT WIPES

Grab & go wipes are packaged in a pop-out dispenser box that allows you to take only one wipe for a clean, non-contaminated wipe every time. This also helps eliminate needless wasted product usage. Available in different models which adapt to a wide range of uses, both in light absorption pack and in heavy absorption pack.

CODE	DESCRIPTION	PACKAGING
402 002 284	DRC wipes • 20.3 x 30.4 cm • 250 wipes/box	4 boxes/case
402 002 286	Spunlace wipes • 25.4 x 33 cm • 200 wipes/box	4 boxes/case



Pictures indicated in this catalogue are representative and not binding for the supplier in terms of layout and colours. They may be subject to changes by the supplier without prior notice.

## NO TOUCH UNIVERSAL KIT

Innovative solution for industrial spills. The NO TOUCH system, composed of a holder, handle and absorbent cloths/pads, is practical and designed to access difficult-to-reach places with ease, and above all without getting your hands dirty.

CODE	DESCRIPTION	BOX AVERAGE ABSORPTION
402 004 195	NO TOUCH Universal Kit (handle + 3 cloths with holder)	5 L
402 004 196	Universal Strong cloths w/NO TOUCH holder • 48 x 38 cm • 25 pcs/box	47 L
402 004 197	Universal Strong pads w/NO TOUCH holder • 46 x 46 cm • 10 pcs/box	57 L
402 004 198	NO TOUCH cloths refill - 48 x 38 cm • 100 pcs/box • (1 holder)	94 L



402 004 195



402 004 196



402 004 197

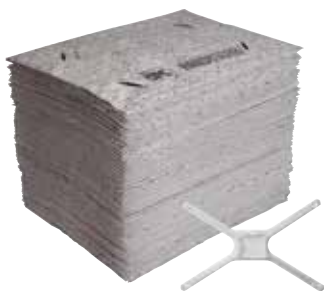

402 004 198



## CLEAN TOOLS ABSORBENTS

Industrial absorbent pads, chemically resistant and long-life. This means that these pads stand up to the hardest tests, with oil, water, solvents and even acids. Absorbent pads are cheaper, very light and long-life and they can be used many times until they are worn out, unlike rags which are considered hazardous waste, and more costly as they are heavy and not very absorbent.

CODE	DESCRIPTION	PACKAGING	BOX AVERAGE ABSORPTION
402 000 106	Clean Tools pad • 30 x 38 cm	10 packs of 50 pads each	38 L



### DEGREASER WIPES

Degreaser wipes ideal for cleaning up tools, dirty products and also hands. Citrus scented degreaser dissolves grime, grease, tar and printer ink. Also acts as a rust inhibitor. Made of polypropylene (PP), it gives the wipes superior strength.

CODE	DESCRIPTION	PACKAGING
402 002 260	Degreaser wipe • 25,4 x 30,4 cm	Can (70 wipes)
402 002 255	Degreaser wipe • 25,4 x 30,4 cm	Box of 6 cans (70 wipes each)

### UNIVERSAL SUPER-ABSORBENT ROLL

AIRBANK PRODUCT

CUSTOMIZABLE PRODUCT



#### High absorbency and liquid retention

Ideal when high absorbency of water, salt water, blood and liquid foodstuffs is required. Composed of two-ply cellulose nonwoven fabric with a sodium polyacrylate mesh between them. In contact with liquids, the granular powder turns into a gel with high retention, as the absorption is based on a chemical/physical process. Used in food industries, medical and pharmaceutical industries, hospitals and funeral homes.



CODE	DESCRIPTION	AVERAGE ABSORPTION
402 004 109	Universal SUPER-ABSORBENT roll • 1.3 x 25 m • 1 piece/box	36 L/m <sup>2</sup>
402 004 110	Universal SUPER ABSORBENT pad • 1.3 x 1 m • 1 piece/box	36 L/m <sup>2</sup>



WATCH THE VIDEO



Pictures indicated in this catalogue are representative and not binding for the supplier in terms of layout and colours. They may be subject to changes by the supplier without prior notice.



### "CHEM ULTRA" SERIES ABSORBENTS

Absorbents made of polypropylene fibre with the addition of a surfactant to be used in cases of large spills or losses consisting of concentrated chemicals (acids, bases) and hazardous liquids in general. The ideal absorbents in the presence of strong chemical corrosiveness. Ideal for use in chemical and pharmaceutical industries. Their colour allows an immediate detection of the product during an emergency. The absorbents of this series combine great absorption capacity with considerable convenience.



#### STRONG POINTS

- It absorbs concentrated chemicals
- High absorption capacity
- Reduced disposal costs
- Save up to 30%.

CODE	DESCRIPTION	BOX AVERAGE ABSORPTION
403 000 141	Chem Ultra absorbent pad • 30 x 30 cm • 100 pieces/box 	41 L
403 000 140	Chem Ultra absorbent pad • 41 x 46 cm • 100 pieces/box 	114 L
403 000 139	Chem Ultra absorbent pad • 41 x 46 cm • 200 pieces/box 	163 L



CODE	DESCRIPTION	BOX AVERAGE ABSORPTION
403 000 142	Chem Ultra absorbent pillow • 25 x 25 cm • 20 pieces/box	57 L
403 000 143	Chem Ultra absorbent pillow • 46 x 46 cm • 10 pieces/box	78 L





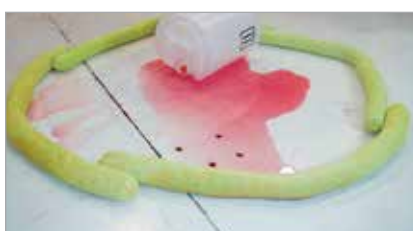

CODE	DESCRIPTION	BOX AVERAGE ABSORPTION
403 000 144	Chem Ultra absorbent sock • Ø 7.6 x 122 cm • 15 pieces/box	84 L
403 000 145	Chem Ultra absorbent sock • Ø 7.6 x 122 cm • 40 pieces/box	220 L
403 000 146	Chem Ultra absorbent sock • Ø 7.6 x 305 cm • 6 pieces/box	84 L



Pictures indicated in this catalogue are representative and not binding for the supplier in terms of layout and colours. They may be subject to changes by the supplier without prior notice.

# ABSORPTION PRODUCTS

## 3 ABSORBENTS FOR CORROSIVE, CAUSTIC AND TOXIC LIQUIDS

CODE	DESCRIPTION		BOX AVERAGE ABSORPTION
403 000 147	Chem Ultra absorbent roll • 81 cm x 46 m • 1 piece/box	 	228 L
403 000 148	Chem Ultra absorbent roll • 41 cm x 46 m • 2 pieces/box	 	228 L



CODE	DESCRIPTION		BOX AVERAGE ABSORPTION
403 000 149	Chem Ultra Drum Top cover • Ø 56 cm • 25 pieces/box		41 L

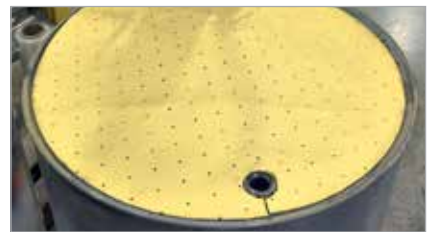

 = Perforated  
Faster absorption

 = Pre-cut  
Greater versatility of use



Pictures indicated in this catalogue are representative and not binding for the supplier in terms of layout and colours. They may be subject to changes by the supplier without prior notice.

# "CHEM STRONG" SERIES ABSORBENTS

Absorbents made of polypropylene fibre with a surfactant to be used in case of big spills and leaks of concentrated chemicals (acids, bases) and hazardous liquids in general, especially when a high mechanical resistance is required, while guaranteeing that no fibres will be released. They greatly restrict evaporation of the treated products and are among the few products in the world capable of absorbing hydrofluoric acid. The ideal absorbents in the presence of strong chemical corrosiveness. Added surfactants to considerably reduce vapour escape. Ideal for the chemical industry and analysis labs. The absorbents of this series guarantee the widest choice of sizes, the best resistance to abrasion and a high absorption rate.



### STRONG POINTS

- It absorbs concentrated chemicals
- They do not release fibres
- High mechanical resistance
- Fast absorption
- Wide range of sizes

CODE	DESCRIPTION	BOX AVERAGE ABSORPTION
403 000 129	Chem Strong absorbent pad packaged in 4 dispensers of 50 pads each • 30 x 30 cm • 200 pieces/box 	76 L
403 000 130	Chem Strong absorbent pad • 41 x 51 cm • 100 pieces/box  	88 L

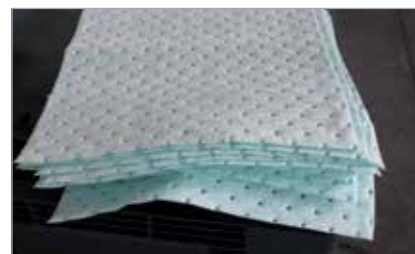

CODE	DESCRIPTION	BOX AVERAGE ABSORPTION
403 000 131	Chem Strong absorbent pillow • 22 x 24 cm • 32 pieces/box	53 L
403 000 132	Chem Strong absorbent pillow • 43 x 48 cm • 16 pieces/box	105 L



Pictures indicated in this catalogue are representative and not binding for the supplier in terms of layout and colours. They may be subject to changes by the supplier without prior notice.









# ABSORPTION PRODUCTS

## 3 ABSORBENTS FOR CORROSIVE, CAUSTIC AND TOXIC LIQUIDS

CODE	DESCRIPTION	BOX AVERAGE ABSORPTION
403 000 133	Chem Strong absorbent sock • Ø 7.6 x 122 cm • 12 pieces/box	45 L
403 000 134	Chem Strong absorbent sock • Ø 7.6 x 366 cm • 4 pieces/box	45 L
403 000 135	Chem Strong absorbent sock • Ø 13 x 300 cm • 4 pieces/box	118 L
403 000 136	Chem Strong absorbent sock • Ø 20 x 300 cm • 4 pieces/box	263 L



CODE	DESCRIPTION		BOX AVERAGE ABSORPTION
403 000 137	Chem Strong absorbent roll (perforated every 46 cm) • 38 cm x 46 m • 2 pieces/box	 	147 L
403 000 138	Chem Strong absorbent roll (perforated every 38 cm and in the centre) • 76 cm x 46 m • 1 piece/box	 	147 L
403 003 756	Chem Strong mini absorbent roll • 19 cm x 15 m (60 sheets) • 1 piece/box	 	12 L



 = Perforated  
Faster absorption

 = Pre-cut  
Greater versatility of use



Pictures indicated in this catalogue are representative and not binding for the supplier in terms of layout and colours. They may be subject to changes by the supplier without prior notice.

### "CHEM MINERAL" SERIES ABSORBENTS



Absorbents made from a revolutionary natural mineral fibre, with nano-reinforcement – 100% eco friendly. Can be used for spills of chemical, acidic and basic substances. Their impressive absorption provides significant disposal and initial procurement savings.



#### STRONG POINTS

- *High absorption capacity: 1 g of mineral fibre absorbs up to 50g of oil compared to 14 g of traditional absorbents (average values)*
- *High speed of absorption: absorbs 99% of the spill in the first 15 minutes*
- *Recovery potential: squeezing out the absorbent allows recovery of the spilled oil*
- *Non-flammable*



CODE	DESCRIPTION	BOX AVERAGE ABSORPTION
403 004 006	Chem Mineral absorbent sock • Ø 8 x 120 cm • 20 pieces/box	120 L
403 004 009	Chem Mineral absorbent pillow • 45 x 45 cm • 30 pieces/box	60 L

The 2-in-1 socks contain absorbent pillows and can thus be used like traditional socks to form barriers, or else opened and the pillows inside them used individually.



CODE	DESCRIPTION	BOX AVERAGE ABSORPTION
403 004 003	2-in-1 Chem Mineral absorbent sock 8 pillows • 8 pieces/box	160 L



WATCH THE VIDEO



Pictures indicated in this catalogue are representative and not binding for the supplier in terms of layout and colours. They may be subject to changes by the supplier without prior notice.

### SOLFORLESS



#### Absorbent and neutralizer for sulphuric acid used in lead-acid batteries, to be used for accidental spills

SOLFORLESS is a product tested and certified by the Department of Chemicals, Materials and Chemical Engineering of the Polytechnic University of Milan, meeting the requirements of decree no. 20 of 24 January 2011 issued by the Italian Ministry of the Environment.

In the event of accidental spillages of battery acid, spread SOLFORLESS® over the whole of the spill.

At the end of the reaction (5 minutes), the resulting slush will have a pH of around 7, that is it neutralizes as well as absorbs the acid.

This mixture can be collected and disposed of as NON-HAZARDOUS SPECIAL WASTE by authorized companies.

#### STRONG POINTS

- 100% ecological (inert mineral powders)
- Completely non-flammable (Reaction to fire class A1)
- Non-toxic and environmentally friendly
- The product has a shelf life of 6 years



### SOLFORLESS®

ABSORBENT AND NEUTRALIZING PRODUCT FOR SULPHURIC ACID



#### APPLICATIONS

- Industrial companies with forklifts
- Battery storage/production
- Hauliers
- Workshops
- Vehicle electricians
- Spare parts dealers
- Car and bike dealerships

#### FEATURES

- Physical appearance: fine powder
- Colour: white/pink
- pH: 8.5-10.5 (10% w/w suspension)
- Electrical conductivity: negative
- Solubility in water: insoluble
- Flash point: non-flammable
- Absorbent and neutralizing power: 530 g of product per 1 litre electrolyte with density 1.26 kg/dm<sup>3</sup>

CODE	DESCRIPTION	PACKAGING	ABSORPTION/NEUTRALIZATION
404 002 226	SOLFORLESS absorbent and neutralizer	5 kg bucket	530 g/l electrolyte with density 1.26 kg/dm <sup>3</sup>
404 002 239		15 kg bucket	

YOU CAN FIND VARIOUS DIFFERENT KITS CONTAINING SOLFORLESS ON PAGES 82 AND 83

WATCH THE VIDEO



Pictures indicated in this catalogue are representative and not binding for the supplier in terms of layout and colours. They may be subject to changes by the supplier without prior notice.



# BATTERY ACID (SULPHURIC ACID) EMERGENCY SIGN

Sign indicating the location of SOLFORLESS product and/or kits (absorbent/neutralising powder pursuant to Italian Ministerial Decree no. 20 of 24/01/11) in the company in order to allow the assigned operatives to identify it rapidly and thus intervene in a timely manner.

The goal of the supplied sign is to rapidly attract workers' attention in an emergency, and it must therefore be placed in a location where it is easily visible even from a distance.

*\*The symbols on the signs/stickers offered by Airbank do not fall within those specified by international standards (EN ISO 7010), and as such purchasers must be aware that they are not displaying a universally recognised symbol but rather a sign which, while it respects the general criteria, does not incorporate the preventive measures specified by the same standard.*



CODE	DESCRIPTION
404 004 165	Battery acid (sulphuric acid) emergency sign, A4



**OUR TECHNICAL DEPARTMENT CAN CALCULATE THE CORRECT QUANTITY OF SOLFORLESS TO MEET THE REQUIREMENTS OF YOUR COMPANY**

**WATCH THE VIDEO**



Pictures indicated in this catalogue are representative and not binding for the supplier in terms of layout and colours. They may be subject to changes by the supplier without prior notice.

### UNI-SAFE



UNI-SAFE is a powder which is able to absorb substances such as nitric acid, sulphuric acid, oils, hydrogen peroxide, bromine etc. while preventing the formation of hazardous gases. The main component of UNI-SAFE is a special polymer with exceptional absorbent power (can absorb up to 75 times its own weight).

CODE	DESCRIPTION	PACKAGING	BOX MAX ABSORPTION
404 004 386	UNI-SAFE absorbent	1 bottle x 0.5 kg	37.5 L
404 004 387	UNI-SAFE absorbent	10 bottles x 0.5 kg	375 L

WATCH THE VIDEO



### NEUTRALIZER FOR ACIDS AND BASES



Acid or base neutralizing powder with KOLOR SAFE® colour-changing process indicating when the base or acid has been neutralized and is safe for final clean-up. Greater neutralizing capacity compared to neutralizing liquids.

CODE	DESCRIPTION	PACKAGING
404 000 152	Base neutralizer	10 x 0.9 kg bottles
404 000 153		4.5 kg bag
404 000 151	Acid neutraliser	10 x 0.9 kg bottles
404 000 150		4.5 kg bag



Pictures indicated in this catalogue are representative and not binding for the supplier in terms of layout and colours. They may be subject to changes by the supplier without prior notice.

## ABSORBENT PRODUCTS FOR OFF-SHORE PLATFORMS

A total of 4580 m of absorbent socks and a total of 10 m<sup>3</sup> of absorbent material were required. Part of the material must be placed inside containers that allow safe storage and a functional handling, transport, and reuse as containers of the contaminated material (once used in depollution operations).  
Socks must have a diameter of at least 20 cm and a length of at least 10 m as well as an excellent mechanical resistance.

### AIRBANK'S SOLUTION:

As for the 10 m<sup>3</sup> of absorbent material, packaging in ISO container DNV 2.7.1 certified for use and offshore lifting has been proposed.



The necessary socks (4,580 m) instead, were placed on 800x1200 plastic pallets with beams. The choice of plastic pallets is due to the greater storage resistance in outdoor areas, unlike traditional wooden pallet.

Above each pallet, an eyelet PVC cover has been placed to protect the material against the elements; in addition, 3 x UN-approved 1000-litre big bags have been added to each pallet, for the disposal of hazardous waste.











# EMERGENCY SPILL KITS FOR INDUSTRY AND TRANSPORT

	KITS FOR OIL AND HYDROCARBON SPILLS .....	page 58
	KITS FOR ALL LIQUID SPILLS.....	page 66
5	KITS FOR SPILLS OF CORROSIVE, CAUSTIC AND TOXIC LIQUIDS.....	page 72
	KITS FOR SPILLS OF SPECIAL LIQUIDS.....	page 78
	EYEWASH STATIONS.....	page 84



## ASSORBIKIT



### Accidental spill kits

Accidental spill kits are the easiest and quickest solution to clean up accidental spills of dangerous and polluting substances. A quick response with the right products in these cases ensures effective and immediate clean-up of land, groundwater and work sites. They consist of different absorbent product lines contained in different types and sizes of container, in order to make it easy for the customer to choose the most suitable kit in accordance with the spilled materials and location.

The absorbent products contained in the kits belong to four categories:



**OIL ONLY** - These kits contain specific oil and hydrocarbon water-repellent absorbents



**UNIVERSAL** - These kits contain absorbents ideal for any type of liquid, even water



**CHEM** - These kits contain absorbents ideal for particularly-aggressive chemical liquids



**SPECIAL KITS** - These kits contain absorbents for specific situations, such as neutralising sulphuric acid and for specific industrial sectors

THEY CAN CONTAIN ABSORBING POWDERS AND FIBRE ABSORBENTS, SUCH AS PADS, PILLOWS AND SOCKS.

**Absorbing powders** are ideal for large spills, because they are fast to dose and they have an instant absorbing capacity.

**Pads and pillows** are ideal for smaller spills and to clean machines or areas that cannot be reached with the powders.

**Socks** are ideal and recommended to delimit the spill. By acting as an absorbing boom, they prevent the liquid from scattering and the spill from expanding, allowing the operator to proceed with the powders or the pads/pillows.



It is essential to place the kits in a visible area that can be easily reached by the operators when an emergency situation should occur. For this reason, Airbank has created a sign\* to indicate the location of the kit inside the company in order to allow the assigned operative to quickly identify it and therefore act in a timely manner. The goal of the supplied sign, to be placed on the wall/racking where the kit is located, is to rapidly attract workers' attention in an emergency, and it must therefore be placed in a location where it is easily visible even from a distance. A second sign carrying the same signal\* is already positioned on the kit's container.

CODE	DESCRIPTION
405 003 855	Spill kit sticker, 9 x h 15 cm
405 003 813	Spill kit sign, A4



CONTROLLO REINTEGRO KIT		SE	SE	SE	SE	SE	SE
GEN							
FEB							
MAR							
APR							
MAG							
GIU							
LUG							
AGO							
SET							
OTT							
NOV							
DIC							

The emergency kit is an indispensable tool in emergency situations, and it must always include every single component. To make it immediately visible that the kit has been used to the HSE or other figures in charge of corporate safety, Airbank has created a seal of integrity: once the kit is opened, the seal is torn indicating that it has been used. In this way, you can easily check the missing components by checking only the contents of those company kits that have the seal torn. Subsequently, the missing pieces will be rearranged and a new integrity seal will be affixed, as well as the check and reinstatement sticker.

CODE	DESCRIPTION
405 004 688	Integrity Seal Sticker - 30 x 5 cm - Pack of 10
405 004 691	Kit Refill Sticker - 6 x 12 cm - Pack of 10

### CREATE YOUR CUSTOMISED KIT WITH THE AIRBANK CONFIGURATOR

If you have specific requirements which are not met by the kits available in the catalogue, compose your customised kit by choosing from a wide range of products, containers and PPE.

\*The symbols on the signs offered by Airbank do not fall within those specified by international standards (EN ISO 7010), and as such purchasers must be aware that they are not displaying a universally recognised symbol but rather a sign which, while it respects the general criteria, does not incorporate the preventive measures codified by the standard itself.





### OIL ONLY WHEELED RESPONSE CONTAINER KIT

 AIRBANK PRODUCT

 CUSTOMIZABLE PRODUCT

Wheeled stackable container, 600 L. Large polyethylene (PE) tank, cover and wheels.



CODE	DESCRIPTION	KIT AVERAGE ABSORPTION
405 000 159	OIL ONLY 600 L wheeled response container kit 1200 x 800 x h 990 mm	408 L
CONTENTS: 200 pads, 16 pillows, 24 socks, 2 pair of gloves, 2 pair of goggles, 4 disposal bags, 2 overalls.		
405 000 160	OIL ONLY 600 L wheeled response container kit 1200 x 800 x h 990 mm	500 L
CONTENTS: 100 pads, 1 roll, 24 socks, 2 pair of gloves, 2 pair of goggles, 4 disposal bags, 2 overalls.		
405 000 161	OIL ONLY 600 L wheeled response container kit 1200 x 800 x h 990 mm	306 L
CONTENTS: 9 OKO-PUR PLUS bags, 1 dustpan, 1 pair of gloves, 1 pair of goggles, 1 overall, 4 disposal bags		
405 000 162	OIL ONLY 600 L wheeled response container kit 1200 x 800 x h 990 mm	189 L
CONTENTS: 9 OKO-PUR KOMPAKT bags, 1 dustpan, 1 pair of gloves, 1 pair of goggles, 1 overall, 4 disposal bags		

Wheeled stackable container, 300 L. Large polyethylene (PE) tank, cover and wheels.



CODE	DESCRIPTION	KIT AVERAGE ABSORPTION
405 000 166	OIL ONLY 300 L wheeled response container kit 1000 x 700 x h 790 mm	173 L
CONTENTS: 100 pads, 4 pillows, 12 socks, 1 pair of gloves, 1 pair of goggles, 3 disposal bags, 1 overall.		

120 / 240 / 360 L polyethylene (PE) container. Wheelie bin model.



CODE	DESCRIPTION	KIT AVERAGE ABSORPTION
405 000 163	OIL ONLY 120 L wheeled response container kit 550 x 500 x h 940 mm	135 L
CONTENTS: 50 pads, 4 pillows, 12 socks, 1 pair of gloves, 1 pair of goggles, 2 disposal bags, 1 overall.		
405 000 164	OIL ONLY 240 L wheeled response container kit 580 x 720 x h 1060 mm	260 L
CONTENTS: 150 pads, 8 pillows, 6 socks, 1 pair of gloves, 1 pair of goggles, 3 disposal bags, 2 overalls.		
405 000 165	OIL ONLY 360 L wheeled response container kit 620 x 865 x h 1100 mm	333 L
CONTENTS: 200 pads, 12 pillows, 16 socks, 2 pair of gloves, 2 pair of goggles, 4 disposal bags, 2 overalls.		

**CUSTOMISE YOUR KIT:** you can choose the absorbing material that best fits your needs  
**REFILL YOUR KIT:** you can order only the absorbing material and the PPE to refill the kit you already have

ON REQUEST

Pictures indicated in this catalogue are representative and not binding for the supplier in terms of layout and colours. They may be subject to changes by the supplier without prior notice.

## 5 KITS FOR OIL AND HYDROCARBON SPILLS

### OIL ONLY CYLINDRICAL CONTAINER KIT

AIRBANK PRODUCT

CUSTOMIZABLE PRODUCT

30, 60, 120, 220 L polyethylene (PE) drums. ADR approved. Anticorrosion. Lid sealed with galvanized metal band.



CODE	DESCRIPTION	KIT AVERAGE ABSORPTION
405 000 167	30 L OIL ONLY cylindrical container kit Ø 320 x h 520 mm	37 L
CONTENTS: 20 pads, 4 socks, 1 pair of gloves, 1 pair of goggles, 1 disposal bag, 1 overall.		
405 000 168	60 L OIL ONLY cylindrical container kit Ø 400 x h 620 mm	79 L
CONTENTS: 20 pads, 4 pillows, 6 socks, 1 pair of gloves, 1 pair of goggles, 2 disposal bags, 1 overall.		
405 000 169	120 L OIL ONLY cylindrical container kit Ø 496 x h 800 mm	143 L
CONTENTS: 100 pads, 2 socks, 1 pair of gloves, 1 pair of goggles, 3 disposal bags, 1 overall.		
405 000 170	220 L OIL ONLY cylindrical container kit Ø 582 x h 985 mm	229 L
CONTENTS: 1 roll, 4 socks, 2 pair of gloves, 2 pair of goggles, 4 disposal bags, 2 overalls.		

### OIL ONLY TROLLEY KIT

AIRBANK PRODUCT

CUSTOMIZABLE PRODUCT

150 L polyethylene trolley case, equipped with a practical handle and two wheels for easy movement.



CODE	DESCRIPTION	KIT AVERAGE ABSORPTION
405 004 874	150 L OIL ONLY trolley kit • 800 x 600 x h 530 mm	117 L
CONTENTS: 50 pads, 4 pillows, 12 socks, 1 bag OIL FREE powder, 1 pair of gloves, 1 pair of goggles, 2 disposal bags, 1 overall.		

### OIL ONLY MAXI CONTAINER KIT

AIRBANK PRODUCT

CUSTOMIZABLE PRODUCT

Rectangular polyethylene (PE) container with hinged upper lid, designed for fork-lift transportation.



CODE	DESCRIPTION	KIT AVERAGE ABSORPTION
405 000 171	OIL ONLY maxi container kit 1870 x 920 x h 1060 mm	908 L
CONTENTS: 200 pads, 16 pillows, 1 roll, 8 socks, 2 pair of gloves, 2 pair of goggles, 10 disposal bags, 2 overalls.		
405 000 172	OIL ONLY maxi container kit 1870 x 920 x h 1060 mm	756 L
CONTENTS: 100 pads, 1 roll, 8 socks, 3 NATURAL CORK SORB bags, 2 pairs of gloves, 2 pairs of goggles, 10 disposal bags, 2 overalls.		
405 000 173	OIL ONLY maxi container kit 1870 x 920 x h 1060 mm	1107 L
CONTENTS: 200 pads, 16 pillows, 1 roll, 12 socks, 2 pair of gloves, 2 pair of goggles, 10 disposal bags, 2 overalls.		

**CUSTOMISE YOUR KIT:** you can choose the absorbing material that best fits your needs  
**REFILL YOUR KIT:** you can order only the absorbing material and the PPE to refill the kit you already have

ON REQUEST

### OIL ONLY CABINET KIT

AIRBANK PRODUCT

CUSTOMIZABLE PRODUCT

Polyethylene (PE) cabinets with one or two doors. Equipped with internal adjustable shelves.



405 000 174



405 000 175

CODE	DESCRIPTION	KIT AVERAGE ABSORPTION
405 000 174	OIL ONLY cabinet kit • 350 x 440 x h 980 mm	75 L

CONTENTS: 100 pads, 8 pillows, 3 socks, 1 pair of gloves, 1 pair of goggles, 2 disposal bags, 1 overall.

405 000 175	OIL ONLY cabinet kit • 350 x 440 x h 1820 mm	164 L
-------------	--	-------

CONTENTS: 100 pads, 20 pillows, 3 socks, 1 pair of gloves, 1 pair of goggles, 2 disposal bags, 1 overall.

405 000 176	OIL ONLY cabinet kit • 700 x 440 x h 1820 mm	298 L
-------------	--	-------

CONTENTS: 150 pads, 16 pillows, 12 socks, 1 OKO-PUR PLUS bag, 1 pair of gloves, 1 pair of goggles, 3 disposal bags, 1 overall.

### OIL ONLY CABINET WITH CASTORS KIT

AIRBANK PRODUCT

CUSTOMIZABLE PRODUCT

Polyethylene (PE) cabinets with one or two doors. Equipped with internal adjustable shelves.



CODE	DESCRIPTION	KIT AVERAGE ABSORPTION
405 000 177	OIL ONLY cabinet with castors kit • 700 x 440 x h 980 mm	102 L

CONTENTS: 50 pads, 4 pillows, 6 socks, 1 pair of gloves, 1 pair of goggles, 2 disposal bags, 1 overall.

405 000 178	OIL ONLY cabinet with castors kit • 700 x 440 x h 980 mm	129 L
-------------	--	-------

CONTENTS: 20 pads, 8 pillows, 12 socks, 5 Kg of OKO-PUR PLUS, 1 pair of gloves, 1 pair of goggles, 2 disposal bags, 1 overall.

405 000 179	OIL ONLY cabinet with castors kit • 700 x 440 x h 980 mm	117 L
-------------	--	-------

CONTENTS: 20 pads, 8 pillows, 12 socks, 10 Kg of OKO-PUR KOMPACT, 1 pair of gloves, 1 pair of goggles, 2 disposal bags, 1 overall.

### OIL ONLY MINI KIT

AIRBANK PRODUCT

CUSTOMIZABLE PRODUCT

Emergency response kit for truck drivers. These emergency kits can be wall mounted or stored in the truck's cab.



CODE	DESCRIPTION	KIT AVERAGE ABSORPTION
405 000 180	OIL ONLY mini kit • 400 x 400 x h 150 mm	28 L

CONTENTS: 15 pads, 3 socks, 1 pair of gloves, 1 pair of goggles, 1 disposal bag.

**CUSTOMISE YOUR KIT:** you can choose the absorbing material that best fits your needs  
**REFILL YOUR KIT:** you can order only the absorbing material and the PPE to refill the kit you already have

ON REQUEST

Pictures indicated in this catalogue are representative and not binding for the supplier in terms of layout and colours. They may be subject to changes by the supplier without prior notice.



## 5 KITS FOR OIL AND HYDROCARBON SPILLS

### OIL ONLY BAG KIT

AIRBANK PRODUCT

CUSTOMIZABLE PRODUCT

Emergency response kits for truck drivers and service interventions.



405 000 182



405 000 183

CODE	DESCRIPTION	KIT AVERAGE ABSORPTION
405 000 182	OIL ONLY bag kit • 420 x 230 x h 370 mm	24 L

CONTENTS: 10 pads, 3 socks, 1 pair of gloves, 1 pair of goggles, 1 disposal bag.

405 000 183	OIL ONLY bag kit • 840 x 350 x h 330 mm	84 L
-------------	---	------

CONTENTS: 50 pads, 8 pillows, 3 socks, OKO-PUR PLUS (0.5 Kg), OKO-PUR COMPACT (1.5 Kg), FIRESORB (0.5 Kg), 1 pair of gloves, 1 pair of goggles, 1 disposal bag.



### OIL ONLY MINERAL CABINET KIT

AIRBANK PRODUCT

CUSTOMIZABLE PRODUCT

Polyethylene (PE) cabinet with castors with two doors. Equipped with adjustable shelves.



CODE	DESCRIPTION	KIT AVERAGE ABSORPTION
405 004 184	OIL ONLY Mineral cabinet kit • 700 x 440 x h 980 mm	90 L

CONTENTS: 10 socks, 15 pillows, 1 pair of gloves, 1 overall, 1 pair of goggles, 2 disposal bags.

**CUSTOMISE YOUR KIT:** you can choose the absorbing material that best fits your needs  
**REFILL YOUR KIT:** you can order only the absorbing material and the PPE to refill the kit you already have

ON REQUEST

### OIL ONLY CABINET KIT

AIRBANK PRODUCT

CUSTOMIZABLE PRODUCT

Single polyethylene (PE) door cabinet.



CODE	DESCRIPTION	KIT AVERAGE ABSORPTION
405 004 181	OIL ONLY cabinet kit • 567 x 375 x h 850 mm	98 L

CONTENTS: 8 socks, 6 pillows, 50 pads, 2 pair of gloves, 2 pair of goggles, 2 disposal bags.

### OIL ONLY MOBILE STATION KIT W/CABINET

AIRBANK PRODUCT

CUSTOMIZABLE PRODUCT

Mobile station kit w/cabinet, for indoor/outdoor use. Easy to assemble and disassemble. Ergonomic handles for ease of use. Solid rubber wheels (Ø 200 mm).



CODE	DESCRIPTION	KIT AVERAGE ABSORPTION
405 004 169	OIL ONLY mobile station kit w/cabinet 580 x 595 x h 1725 mm	111 L

CONTENTS: 70 pads, 6 socks, 2 pairs of gloves, 2 pairs of goggles, 2 disposable bags, OKO-PUR PLUS 5 kg.

\*product to be assembled

### OIL ONLY MOBILE STATION KIT W/MANHOLE

AIRBANK PRODUCT

CUSTOMIZABLE PRODUCT

Mobile station kit w/manhole, for indoor/outdoor use. Easy to assemble and disassemble. Ergonomic handles for ease of use. Solid rubber wheels (Ø 200 mm).



CODE	DESCRIPTION	KIT AVERAGE ABSORPTION
405 004 817	OIL ONLY mobile station kit w/manhole 580 x 595 x h 1725 mm	86 L

CONTENTS: 70 pads, 6 socks, 1 pair of gloves, 1 pair of goggles, 2 disposal bags, 1 manhole cover.

\*product to be assembled

**CUSTOMISE YOUR KIT:** you can choose the absorbing material that best fits your needs  
**REFILL YOUR KIT:** you can order only the absorbing material and the PPE to refill the kit you already have

ON REQUEST

Pictures indicated in this catalogue are representative and not binding for the supplier in terms of layout and colours. They may be subject to changes by the supplier without prior notice.

## 5 KITS FOR OIL AND HYDROCARBON SPILLS

### OIL ONLY MOBILE STATION KIT W/ROLL HOLDER

AIRBANK PRODUCT

CUSTOMIZABLE  
PRODUCT

Mobile station kit w/paper towel roll holder, for indoor use. Easy to assemble and disassemble. Ergonomic handles for ease of use. Solid rubber wheels (Ø 200 mm).

**K**  
OIL ONLY



CODE	DESCRIPTION	KIT AVERAGE ABSORPTION
405 004 820	OIL ONLY mobile station kit w/paper towel 580 x 595 x h 1725 mm	49 L

CONTENTS: 1 OKOPUR PLUS bag, 1 mini roll 19 cm x 15 m, 1 pair of gloves, 1 pair of goggles, 2 disposal bags.

\*product to be assembled

### OIL ONLY MOBILE STATION KIT W/BAG

AIRBANK PRODUCT

CUSTOMIZABLE  
PRODUCT

Mobile station kit w/bag, for indoor/outdoor use. Easy to assemble and disassemble. Ergonomic handles for ease of use. Solid rubber wheels (Ø 200 mm).

**K**  
OIL ONLY



CODE	DESCRIPTION	KIT AVERAGE ABSORPTION
405 004 173	OIL ONLY mobile station kit w/bag 580 x 595 x h 1725 mm	62 L

CONTENTS: 15 pads, 3 socks, 1 pair of gloves, 1 pair of goggles, 2 disposal bags, 1 OKO-PUR PLUS bag.

\*product to be assembled

**CUSTOMISE YOUR KIT:** you can choose the absorbing material that best fits your needs  
**REFILL YOUR KIT:** you can order only the absorbing material and the PPE to refill the kit you already have

ON REQUEST

Pictures indicated in this catalogue are representative and not binding for the supplier in terms of layout and colours. They may be subject to changes by the supplier without prior notice.



### OIL ONLY TROLLEY KIT

 AIRBANK PRODUCT

 CUSTOMIZABLE PRODUCT

Mobile container, suitable for indoor and outdoor use. Compact, space-saving design with rubber wheels and cover. Capacity 75 L. Each trolley will be provided with gasket and lock.



CODE	DESCRIPTION	KIT AVERAGE ABSORPTION
405 004 176	OKO-PUR granules trolley kit w/OIL ONLY dustpan 435 x 590 x h 1070 mm	21 L
CONTENTS: plastic dustpan and 1 bag OKO-PUR KOMPAKT		
405 004 177	OKO-PUR powder trolley kit w/OIL ONLY dustpan 435 x 590 x h 1070 mm	34 L
CONTENTS: plastic dustpan and 1 bag OKO-PUR PLUS		
405 004 263	OIL FREE powder trolley kit w/OIL ONLY dustpan 435 x 590 x h 1070 mm	42 L
CONTENTS: plastic dustpan and 1 bag OIL FREE powder		
405 004 264	OIL FREE granules trolley kit w/OIL ONLY dustpan 435 x 590 x h 1070 mm	28 L
CONTENTS: plastic dustpan and 1 bag OIL FREE granules		
405 004 265	NATURAL CORK SORB trolley kit w/OIL ONLY dustpan 435 x 590 x h 1070 mm	16 L
CONTENTS: plastic dustpan and 1 bag NATURAL CORK SORB		
405 004 210	OIL ONLY trolley kit 435 x 590 x h 1070 mm	93 L

CONTENTS: 8 socks, 50 pads, 4 pillows, 1 pair of gloves, 1 overall, 1 pair of goggles, 1 disposal bag.

WATCH THE VIDEO



### OIL ONLY ROLL HOLDER DISPENSER

 AIRBANK PRODUCT

 CUSTOMIZABLE PRODUCT

Floor-mounted paper towel roll dispenser, in painted metal, ideal for industrial environments and workshops. Maximum roll dimensions ø 38 cm h 38 cm.



CODE	DESCRIPTION	AVERAGE ABSORPTION
405 004 852	OIL ONLY paper towel roll dispenser Dimensions 510 x 520 x h 860 mm	94 L

**CUSTOMISE YOUR KIT:** you can choose the absorbing material that best fits your needs  
**REFILL YOUR KIT:** you can order only the absorbing material and the PPE to refill the kit you already have

ON REQUEST

Pictures indicated in this catalogue are representative and not binding for the supplier in terms of layout and colours. They may be subject to changes by the supplier without prior notice.

## 5 KITS FOR OIL AND HYDROCARBON SPILLS

### UNIVERSAL WHEELED RESPONSE CONTAINER KIT

 AIRBANK PRODUCT

 CUSTOMIZABLE PRODUCT

Wheeled stackable container, 600 L. Large polyethylene (PE) tank, cover and wheels.



CODE	DESCRIPTION	KIT AVERAGE ABSORPTION
405 000 184	UNIVERSAL 600 L wheeled response container kit 1200 x 800 x h 990 mm	440 L
CONTENTS: 100 pads, 16 pillows, 1 roll, 6 socks, 2 pairs of goggles, 2 pairs of gloves, 4 disposal bags, 2 overalls.		
405 000 185	UNIVERSAL 600 L wheeled response container kit 1200 x 800 x h 990 mm	238 L 
CONTENTS: 7 FIRESORB bags, 1 dustpan, 1 pair of gloves, 1 pair of goggles, 1 overall, 4 disposal bags.		
405 000 186	UNIVERSAL 600 L wheeled response container kit 1200 x 800 x h 990 mm	238 L 
CONTENTS: 14 STERILSORB bags, 1 dustpan, 1 pair of gloves, 1 pair of goggles, 1 overall, 4 disposal bags.		

Wheeled stackable container, 300 L. Large polyethylene (PE) tank, cover and wheels.



CODE	DESCRIPTION	KIT AVERAGE ABSORPTION
405 000 190	UNIVERSAL 300 L wheeled response container kit 1000 x 700 x h 790 mm	153 L
CONTENTS: 50 pads, 12 pillows, 12 socks, 1 pair of goggles, 1 pair of gloves, 3 disposal bags, 1 overall.		

120 / 240 / 360 L polyethylene (PE) container. Wheelie bin model.



CODE	DESCRIPTION	KIT AVERAGE ABSORPTION
405 000 187	UNIVERSAL 120 L wheeled response container kit 550 x 500 x h 940 mm	130 L
CONTENTS: 50 pads, 4 pillows, 12 socks, 1 pair of goggles, 1 pair of gloves, 2 disposal bags, 1 overall.		
405 000 188	UNIVERSAL 240 L wheeled response container kit 580 x 720 x h 1060 mm	245 L
CONTENTS: 150 pads, 8 pillows, 6 socks, 1 pair of goggles, 1 pair of gloves, 3 disposal bags, 1 overall.		
405 000 189	UNIVERSAL 360 L wheeled response container kit 620 x 865 x h 1100 mm	314 L
CONTENTS: 200 pads, 12 pillows, 16 socks, 2 pairs of goggles, 2 pairs of gloves, 4 disposal bags, 2 overalls.		

### UNIVERSAL CYLINDRICAL CONTAINER KIT

 AIRBANK PRODUCT

 CUSTOMIZABLE PRODUCT

60 L UV resistant polyethylene (PE) drum. ADR approved. With cover sealed with galvanized metal band.



CODE	DESCRIPTION	KIT AVERAGE ABSORPTION
405 000 191	UNIVERSAL 60 L cylindrical container kit • Ø 400 x 620 mm	77 L
CONTENTS: 20 pads, 4 pillows, 6 socks, 1 pair of goggles, 1 pair of gloves, 2 disposal bags, 1 overall.		

**CUSTOMISE YOUR KIT:** you can choose the absorbing material that best fits your needs  
**REFILL YOUR KIT:** you can order only the absorbing material and the PPE to refill the kit you already have

ON REQUEST

Pictures indicated in this catalogue are representative and not binding for the supplier in terms of layout and colours. They may be subject to changes by the supplier without prior notice.

### UNIVERSAL TROLLEY KIT

AIRBANK PRODUCT

CUSTOMIZABLE PRODUCT

150 L polyethylene trolley case, equipped with a practical handle and two wheels for easy movement.



CODE	DESCRIPTION	KIT AVERAGE ABSORPTION
405 004 875	150 L UNIVERSAL trolley kit • 800 x 600 x h 530 mm	147 L

CONTENTS: 50 pads, 4 pillows, 12 socks, 1 FIRESORB bag, 1 pair of gloves, 1 pair of goggles, 2 disposal bags, 1 overall.

### UNIVERSAL CABINET KIT

AIRBANK PRODUCT

CUSTOMIZABLE PRODUCT

Polyethylene (PE) cabinets with one or two doors. Equipped with internal adjustable shelves.



CODE	DESCRIPTION	KIT AVERAGE ABSORPTION
405 000 192	UNIVERSAL cabinet kit • 350 x 440 x h 980 mm	47 L

CONTENTS: 100 pads, 8 pillows, 3 socks, 1 pair of goggles, 1 pair of gloves, 2 disposal bags, 1 overall.

405 000 193	UNIVERSAL cabinet kit • 350 x 440 x h 1820 mm	171 L
-------------	---	-------

CONTENTS: 100 pads, 20 pillows, 3 socks, 1 pair of goggles, 1 pair of gloves, 2 disposal bags, 1 overall.

405 000 194	UNIVERSAL cabinet kit • 700 x 440 x h 1820 mm	282 L
-------------	---	-------

CONTENTS: 150 pads, 16 pillows, 12 socks, 1 FIRESORB bag, 1 pair of goggles, 1 pair of gloves, 3 disposal bags, 1 overall.

### UNIVERSAL CABINET WITH CASTORS KIT

AIRBANK PRODUCT

CUSTOMIZABLE PRODUCT

Polyethylene (PE) cabinets with one or two doors. Equipped with internal adjustable shelves.



CODE	DESCRIPTION	KIT AVERAGE ABSORPTION
405 000 195	UNIVERSAL cabinet with castors kit • 700 x 440 x h 980 mm	81 L

CONTENTS: 50 pads, 4 pillows, 3 socks, 1 pair of goggles, 1 pair of gloves, 2 disposal bags, 1 overall.

405 000 196	UNIVERSAL cabinet with castors kit • 700 x 440 x h 980 mm	118 L
-------------	---	-------

CONTENTS: 20 pads, 8 pillows, 12 socks, 1 FIRESORB bag, 1 pair of goggles, 1 pair of gloves, 2 disposal bags, 1 overall.

**CUSTOMISE YOUR KIT:** you can choose the absorbing material that best fits your needs  
**REFILL YOUR KIT:** you can order only the absorbing material and the PPE to refill the kit you already have

ON REQUEST

Pictures indicated in this catalogue are representative and not binding for the supplier in terms of layout and colours. They may be subject to changes by the supplier without prior notice.



## 5 KITS FOR ALL LIQUID SPILLS

### UNIVERSAL MINI KIT

 AIRBANK PRODUCT

 CUSTOMIZABLE PRODUCT

Emergency response kit for truck drivers. These emergency kits can be wall mounted or stored in the truck's cab.



CODE	DESCRIPTION	KIT AVERAGE ABSORPTION
405 000 197	UNIVERSAL mini kit • 400 x 400 x h 150 mm	26 L

CONTENTS: 15 pads, 3 socks, 1 pair of goggles, 1 pair of gloves, 2 disposal bags.

### UNIVERSAL BAG KIT

 AIRBANK PRODUCT

 CUSTOMIZABLE PRODUCT

Emergency response kits for truck drivers and service interventions.



405 000 199



405 000 200

CODE	DESCRIPTION	KIT AVERAGE ABSORPTION
405 000 199	UNIVERSAL bag kit • 420 x 230 x h 370 mm	30 L

CONTENTS: 20 pads, 3 socks, 1 pair of goggles, 1 pair of gloves, 1 disposal bag.

405 000 200	UNIVERSAL bag kit • 840 x 350 x h 330 mm	79 L
-------------	--	------

CONTENTS: 50 pads, 8 pillows, 3 socks, FIRESORB (2 Kg), 1 pair of goggles, 1 pair of gloves, 1 disposal bag.

### UNIVERSAL MINERAL CABINET KIT

 AIRBANK PRODUCT

 CUSTOMIZABLE PRODUCT

Polyethylene (PE) cabinet with castors with two doors. Equipped with adjustable shelves.



CODE	DESCRIPTION	KIT AVERAGE ABSORPTION
405 004 185	UNIVERSAL Mineral cabinet kit • 700 x 440 x h 980 mm	90 L

CONTENTS: 10 socks, 15 pillows, 1 pair of gloves, 1 overall, 1 safety mask, 1 pair of goggles, 2 disposal bags.

**CUSTOMISE YOUR KIT:** you can choose the absorbing material that best fits your needs  
**REFILL YOUR KIT:** you can order only the absorbing material and the PPE to refill the kit you already have

ON REQUEST

Pictures indicated in this catalogue are representative and not binding for the supplier in terms of layout and colours. They may be subject to changes by the supplier without prior notice.

### UNIVERSAL CABINET KIT

 AIRBANK PRODUCT

 CUSTOMIZABLE PRODUCT

Single polyethylene (PE) door cabinet.



CODE	DESCRIPTION	KIT AVERAGE ABSORPTION
405 004 182	UNIVERSAL cabinet kit • 565 x 375 x h 850 mm	94 L

CONTENTS: 8 socks, 6 pillows, 50 pads, 2 pair of gloves, 2 pair of goggles, 2 disposal bags.

### UNIVERSAL MOBILE STATION KIT W/CABINET

 AIRBANK PRODUCT

 CUSTOMIZABLE PRODUCT

Mobile station kit w/cabinet, for indoor/outdoor use. Easy to assemble and disassemble. Ergonomic handles for ease of use. Solid rubber wheels (Ø 200 mm).



CODE	DESCRIPTION	KIT AVERAGE ABSORPTION
405 004 170	UNIVERSAL mobile station kit w/cabinet 580 x 595 x h 1725 mm	97 L

CONTENTS: 70 pads, 6 socks, 2 pairs of goggles, 2 pairs of gloves, 2 chemical overalls, 2 disposal bags, 1 FIRESORB bag.

*\*product to be assembled*

### UNIVERSAL MOBILE STATION KIT W/MANHOLE

 AIRBANK PRODUCT

 CUSTOMIZABLE PRODUCT

Mobile station kit w/manhole, for indoor/outdoor use. Easy to assemble and disassemble. Ergonomic handles for ease of use. Solid rubber wheels (Ø 200 mm).



CODE	DESCRIPTION	KIT AVERAGE ABSORPTION
405 004 818	UNIVERSAL mobile station kit w/manhole 580 x 595 x h 1725 mm	80 L

CONTENTS: 70 pads, 6 socks, 1 pair of gloves, 1 pair of goggles, 2 disposal bags, 1 manhole cover.

*\*product to be assembled*

**CUSTOMISE YOUR KIT:** you can choose the absorbing material that best fits your needs  
**REFILL YOUR KIT:** you can order only the absorbing material and the PPE to refill the kit you already have

ON REQUEST

Pictures indicated in this catalogue are representative and not binding for the supplier in terms of layout and colours. They may be subject to changes by the supplier without prior notice.

## 5 KITS FOR ALL LIQUID SPILLS

### UNIVERSAL MOBILE STATION KIT W/ROLL HOLDER

AIRBANK PRODUCT

CUSTOMIZABLE PRODUCT

Mobile station kit w/paper towel roll holder, for indoor use. Easy to assemble and disassemble. Ergonomic handles for ease of use. Solid rubber wheels (Ø 200 mm).



CODE	DESCRIPTION	KIT AVERAGE ABSORPTION
405 004 821	UNIVERSAL mobile station kit w/paper towel roll holder 580 x 595 x h 1725 mm	32 L

CONTENTS: 1 FIRESORB (35L) bag, 1 mini roll 19 cm x15 m, 1 pair of gloves, 1 pair of goggles, 2 disposal bags.

*\*product to be assembled*

### UNIVERSAL MOBILE STATION KIT W/BAG

AIRBANK PRODUCT

CUSTOMIZABLE PRODUCT

Mobile station kit w/bag, for indoor/outdoor use. Easy to assemble and disassemble. Ergonomic handles for ease of use. Solid rubber wheels (Ø 200 mm).



CODE	DESCRIPTION	KIT AVERAGE ABSORPTION
405 004 174	UNIVERSAL mobile station kit w/bag 580 x 595 x h 1725 mm	43 L

CONTENTS: 15 pads, 3 socks, 1 pair of gloves, 1 pair of goggles, 1 disposal bag, 1 FIRESORB bag.

*\*product to be assembled*

**CUSTOMISE YOUR KIT:** you can choose the absorbing material that best fits your needs  
**REFILL YOUR KIT:** you can order only the absorbing material and the PPE to refill the kit you already have

ON REQUEST

Pictures indicated in this catalogue are representative and not binding for the supplier in terms of layout and colours. They may be subject to changes by the supplier without prior notice.

### UNIVERSAL TROLLEY KIT

 AIRBANK PRODUCT

 CUSTOMIZABLE PRODUCT

Trolley kit complete with dustpan. Mobile container, suitable for indoor and outdoor use. Compact, space-saving design with rubber wheels and cover. Capacity 75 L. Each trolley will be provided with gasket and lock.



CODE	DESCRIPTION	KIT AVERAGE ABSORPTION
405 004 178	FIRESORB powder trolley kit w/UNIVERSAL dustpan 435 x 590 x h 1070 mm	34 L
405 004 179	STONE UNIVERSAL SORB ECO trolley kit w/UNIVERSAL dustpan 435 x 590 x h 1070 mm	30 L
405 004 180	STONE UNIVERSAL SORB trolley kit w/UNIVERSAL dustpan 435 x 590 x h 1070 mm	37 L
405 004 211	UNIVERSAL trolley kit 435 x 590 x h 1070 mm	88 L

CONTENTS: plastic dustpan and 1 FIRESORB bag.

CONTENTS: plastic dustpan and 1 STONE UNIVERSAL SORB ECO bag.

CONTENTS: plastic dustpan and 1 STONE UNIVERSAL SORB bag.

CONTENTS: 8 socks, 50 pads, 4 pillows, 1 pair of gloves, 1 overall, 1 pair of goggles, 1 disposal bag.



WATCH THE VIDEO



### UNIVERSAL ROLL HOLDER DISPENSER

 AIRBANK PRODUCT

 CUSTOMIZABLE PRODUCT

Floor-mounted paper towel roll dispenser, in painted metal, ideal for industrial environments and workshops. Maximum roll dimensions ø 38 cm h 38 cm.



CODE	DESCRIPTION	AVERAGE ABSORPTION
405 004 853	UNIVERSAL paper towel roll dispenser Dimensions 510 x 520 x h 860 mm	89 L

**CUSTOMISE YOUR KIT:** you can choose the absorbing material that best fits your needs  
**REFILL YOUR KIT:** you can order only the absorbing material and the PPE to refill the kit you already have

ON REQUEST

Pictures indicated in this catalogue are representative and not binding for the supplier in terms of layout and colours. They may be subject to changes by the supplier without prior notice.



## 5 KITS FOR ALL LIQUID SPILLS

### CHEM WHEELED RESPONSE CONTAINER KIT

AIRBANK PRODUCT

CUSTOMIZABLE PRODUCT

Wheeled stackable container, 600 L. Large polyethylene (PE) tank, cover and wheels.



CODE	DESCRIPTION	KIT AVERAGE ABSORPTION
405 000 202	CHEM 600 L wheeled response container kit 1200 x 800 x h 990 mm	467 L

CONTENTS: 100 pads, 16 pillows, 1 roll, 6 socks, 2 pairs of goggles, 2 pairs of gloves, 4 disposal bags, 2 overalls, 1 safety mask.

Wheeled stackable container, 300 L. Large polyethylene (PE) tank, cover and wheels.



CODE	DESCRIPTION	KIT AVERAGE ABSORPTION
405 000 207	CHEM 300 L wheeled response container kit 1000 x 700 x h 790 mm	161 L

CONTENTS: 50 pads, 12 pillows, 12 socks, 1 pair of goggles, 1 pair of gloves, 2 disposal bags, 1 overall, 1 safety mask.

120 / 240 / 360 L polyethylene (PE) container. Wheelie bin model.



CODE	DESCRIPTION	KIT AVERAGE ABSORPTION
405 000 204	CHEM 120 L wheeled response container kit 550 x 500 x h 940 mm	138 L

CONTENTS: 50 pads, 4 pillows, 12 socks, 1 pair of goggles, 1 pair of gloves, 2 disposal bags, 1 overall, 1 safety mask.

405 000 205	CHEM 240 L wheeled response container kit 580 x 720 x h 1060 mm	269 L
-------------	--	-------

CONTENTS: 150 pads, 8 pillows, 6 socks, 1 pair of goggles, 1 pair of gloves, 3 disposal bags, 1 overall, 1 safety mask.

405 000 206	CHEM 360 L wheeled response container kit 620 x 865 x h 1100 mm	345 L
-------------	--	-------

CONTENTS: 200 pads, 12 pillows, 16 socks, 2 pairs of goggles, 2 pairs of gloves, 4 disposal bags, 2 overalls, 1 safety mask.

### CHEM CYLINDRICAL CONTAINER KIT

AIRBANK PRODUCT

CUSTOMIZABLE PRODUCT

60 L UV resistant polyethylene (PE) drum. ADR approved. With cover sealed with galvanized metal band.



CODE	DESCRIPTION	KIT AVERAGE ABSORPTION
405 000 208	CHEM 60 L cylindrical container kit • Ø 400 x 620 mm	81 L

CONTENTS: 20 pads, 4 pillows, 6 socks, 1 pair of goggles, 1 pair of gloves, 2 disposal bags, 1 overall, 1 safety mask.

**CUSTOMISE YOUR KIT:** you can choose the absorbing material that best fits your needs  
**REFILL YOUR KIT:** you can order only the absorbing material and the PPE to refill the kit you already have

ON REQUEST

### CHEM TROLLEY KIT

AIRBANK PRODUCT

CUSTOMIZABLE PRODUCT

150 L polyethylene trolley case, equipped with a practical handle and two wheels for easy movement.



CODE	DESCRIPTION	KIT AVERAGE ABSORPTION
405 004 876	150 L UNIVERSAL trolley kit • 800 x 600 x h 530 mm	175 L

CONTENTS: 50 pads, 4 pillows, 12 socks, 1 STONE UNIVERSAL SORB bag, 1 pair of gloves, 1 pair of goggles, 1 mask, 2 disposal bags, 1 overall.

### CHEM CABINET KIT

AIRBANK PRODUCT

CUSTOMIZABLE PRODUCT

Polyethylene (PE) cabinets with one or two doors. Equipped with internal adjustable shelves.



405 000 209



405 000 210



405 000 211

CODE	DESCRIPTION	KIT AVERAGE ABSORPTION
405 000 209	CHEM cabinet kit • 350 x 440 x h 980 mm	80 L

CONTENTS: 100 pads, 8 pillows, 3 socks, 1 pair of goggles, 1 pair of gloves, 2 disposal bags, 1 overall, 1 safety mask.

405 000 210	CHEM cabinet kit • 350 x 440 x h 1820 mm	134 L
-------------	--	-------

CONTENTS: 100 pads, 20 pillows, 3 socks, 1 pair of goggles, 1 pair of gloves, 2 disposal bags, 1 overall, 1 safety mask.

405 000 211	CHEM cabinet kit • 700 x 440 x h 1820 mm	304 L
-------------	--	-------

CONTENTS: 150 pads, 16 pillows, 12 socks, 1 FIRESORB bag, 1 pair of goggles, 1 pair of gloves, 2 disposal bags, 1 overall, 1 safety mask.

### CHEM CABINET WITH CASTORS KIT

AIRBANK PRODUCT

CUSTOMIZABLE PRODUCT

Polyethylene (PE) cabinet with castors with two doors. Equipped with internal adjustable shelves.



CODE	DESCRIPTION	KIT AVERAGE ABSORPTION
405 000 212	CHEM cabinet with castors kit • 700 x 440 x h 980 mm	105 L

CONTENTS: 50 pads, 4 pillows, 6 socks, 1 pair of goggles, 1 pair of gloves, 2 disposal bags, 1 overall, 1 safety mask.

405 000 213	CHEM cabinet with castors kit • 700 x 440 x h 980 mm	121 L
-------------	--	-------

CONTENTS: 20 pads, 8 pillows, 12 socks, 1 FIRESORB bag, 1 pair of goggles, 1 pair of gloves, 2 disposal bags, 1 overall, 1 safety mask.

**CUSTOMISE YOUR KIT:** you can choose the absorbing material that best fits your needs  
**REFILL YOUR KIT:** you can order only the absorbing material and the PPE to refill the kit you already have

ON REQUEST

## 5 KITS FOR SPILLS OF CORROSIVE, CAUSTIC AND TOXIC LIQUIDS

### CHEM MINI KIT

AIRBANK PRODUCT

CUSTOMIZABLE PRODUCT

Emergency response kit for truck drivers. These emergency kits can be wall mounted or stored in the truck's cab.



CODE	DESCRIPTION	KIT AVERAGE ABSORPTION
405 000 215	CHEM mini kit • 400 x 400 x h 150 mm	29 L

CONTENTS: 15 pads, 3 socks, 1 pair of goggles, 1 pair of gloves, 2 disposal bags, 1 safety mask.

### CHEM BAG KIT

AIRBANK PRODUCT

CUSTOMIZABLE PRODUCT

Emergency response kits for truck drivers and service interventions.



405 000 217

CODE	DESCRIPTION	KIT AVERAGE ABSORPTION
405 000 217	CHEM bag kit • 420 x 230 x h 370 mm	25 L

CONTENTS: 20 pads, 3 socks, 1 pair of goggles, 1 pair of gloves, 2 disposal bags, 1 safety mask.



405 000 218

405 000 218	CHEM bag kit • 840 x 350 x h 330 mm	66 L
-------------	-------------------------------------	------

CONTENTS: 50 pads, 8 pillows, 3 socks, FIRESORB (2 Kg), 1 pair of goggles, 1 pair of gloves, 1 disposal bag, 1 safety mask.



### CHEM MINERAL CABINET KIT

AIRBANK PRODUCT

CUSTOMIZABLE PRODUCT

Polyethylene (PE) cabinet with castors with two doors. Equipped with adjustable shelves.



CODE	DESCRIPTION	KIT AVERAGE ABSORPTION
405 004 186	CHEM Mineral cabinet kit • 700 x 440 x h 980 mm	90 L

CONTENTS: 10 socks, 15 pillows, 1 pair of gloves, 1 overall, 1 safety mask, 1 pair of goggles, 2 disposal bags.

**CUSTOMISE YOUR KIT:** you can choose the absorbing material that best fits your needs  
**REFILL YOUR KIT:** you can order only the absorbing material and the PPE to refill the kit you already have

ON REQUEST

Pictures indicated in this catalogue are representative and not binding for the supplier in terms of layout and colours. They may be subject to changes by the supplier without prior notice.

### CHEM CABINET KIT

 AIRBANK PRODUCT

 CUSTOMIZABLE PRODUCT

Single polyethylene (PE) door cabinet.



CODE	DESCRIPTION	KIT AVERAGE ABSORPTION
405 004 183	CHEM cabinet kit • 565 x 375 x h 850 mm	101 L

CONTENTS: 50 pads, 8 socks, 6 pillows, 2 pairs of gloves, 2 overalls, 2 safety mask, 2 pairs of goggles, 2 disposal bag.

### CHEM MOBILE STATION KIT W/CABINET

 AIRBANK PRODUCT

 CUSTOMIZABLE PRODUCT

Mobile station kit w/cabinet, for indoor/outdoor use. Easy to assemble and disassemble. Ergonomic handles for ease of use. Solid rubber wheels (Ø 200 mm).



CODE	DESCRIPTION	KIT AVERAGE ABSORPTION
405 004 171	CHEM mobile station kit w/cabinet 580 x 595 x h 1725 mm	128 L

CONTENTS: 70 pads, 6 socks, 2 pairs of goggles, 2 pairs of gloves, 2 chemical overalls, 1 mask, 2 disposal bags, 1 bag STONE UNIVERSAL SORB.

*\*product to be assembled*

### CHEM MOBILE STATION KIT W/MANHOLE

 AIRBANK PRODUCT

 CUSTOMIZABLE PRODUCT

Mobile station kit w/manhole, for indoor/outdoor use. Easy to assemble and disassemble. Ergonomic handles for ease of use. Solid rubber wheels (Ø 200 mm).



CODE	DESCRIPTION	KIT AVERAGE ABSORPTION
405 004 847	CHEM mobile station kit w/manhole 580 x 595 x h 1725 mm	90 L

CONTENTS: 70 pads, 6 socks, 1 pair of gloves, 1 pair of goggles, 1 overall, 1 mask, 2 disposal bags, 1 manhole.

*\*product to be assembled*

**CUSTOMISE YOUR KIT:** you can choose the absorbing material that best fits your needs  
**REFILL YOUR KIT:** you can order only the absorbing material and the PPE to refill the kit you already have

ON REQUEST

Pictures indicated in this catalogue are representative and not binding for the supplier in terms of layout and colours. They may be subject to changes by the supplier without prior notice.



## 5 KITS FOR SPILLS OF CORROSIVE, CAUSTIC AND TOXIC LIQUIDS

### CHEM MOBILE STATION KIT W/ROLL HOLDER

AIRBANK PRODUCT

CUSTOMIZABLE PRODUCT

Mobile station kit w/paper towel roll holder, for indoor use. Easy to assemble and disassemble. Ergonomic handles for ease of use. Solid rubber wheels (Ø 200 mm).



CODE	DESCRIPTION	KIT AVERAGE ABSORPTION
405 004 819	CHEM mobile station kit w/paper towel roll holder 580 x 595 x h 1725 mm	49 L

CONTENTS: 1 STONE UNIVERSAL SORB (5 kg) bag, 1 mini roll 19 cm x15 m, 1 pair of gloves, 1 pair of goggles, 2 disposal bags.

\*product to be assembled

### CHEM MOBILE STATION KIT W/BAG

AIRBANK PRODUCT

CUSTOMIZABLE PRODUCT

Mobile station kit w/bag, for indoor/outdoor use. Easy to assemble and disassemble. Ergonomic handles for ease of use. Solid rubber wheels (Ø 200 mm).



CODE	DESCRIPTION	KIT AVERAGE ABSORPTION
405 004 175	CHEM mobile station kit w/bag 580 x 595 x h 1725 mm	67 L

CONTENTS: 15 pads, 3 socks, 1 pair of gloves, 1 pair of goggles, 1 safety mask, 1 disposal bag, 1 STONE UNIVERSAL SORB bag.

\*product to be assembled

**CUSTOMISE YOUR KIT:** you can choose the absorbing material that best fits your needs  
**REFILL YOUR KIT:** you can order only the absorbing material and the PPE to refill the kit you already have

ON REQUEST

### CHEM TROLLEY KIT

 AIRBANK PRODUCT

 CUSTOMIZABLE PRODUCT

Mobile container, suitable for indoor and outdoor use. Compact, space-saving design with rubber wheels and cover. Capacity 75 L. Each trolley will be provided with gasket and lock.



CODE	DESCRIPTION	KIT AVERAGE ABSORPTION
405 004 212	CHEM trolley kit • 435 x 590 x h 1070 mm	96 L

CONTENTS: 8 socks, 50 pads, 4 pillows, 1 pair of neoprene gloves, 1 overall, 1 mask, 1 pair of goggles, 1 disposal bag.



WATCH THE VIDEO



### CHEM ROLL HOLDER DISPENSER

 AIRBANK PRODUCT

 CUSTOMIZABLE PRODUCT

Floor-mounted paper towel roll dispenser, in painted metal, ideal for industrial environments and workshops. Maximum roll dimensions ø 38 cm h 38 cm.



CODE	DESCRIPTION	AVERAGE ABSORPTION
405 004 854	CHEM paper towel roll dispenser Dimensions 510 x 520 x h 860 mm	74.5 L

**CUSTOMISE YOUR KIT:** you can choose the absorbing material that best fits your needs  
**REFILL YOUR KIT:** you can order only the absorbing material and the PPE to refill the kit you already have

ON REQUEST

## 5 KIT FOR SPILLS OF SPECIAL LIQUIDS

### SPECIAL CHEMICAL IDENTIFICATION KIT



Classifier strips to identify what liquids have been accidentally spilled. Designed to identify hazardous acids/bases, oxidizers, fluorides, petroleum, organic solvents, iodine, bromine and chlorine. Dip classifier strip vertically into liquid and lay it flat on the colour chart provided with the kit to compare. After identifying the liquid, responders will know how to deal with the spill, using the appropriate absorbent or neutralizing product.

CODE	DESCRIPTION
405 000 219	Chemical classifier kit in special tube: 6 classifier strips, chemical classifier chart
405 000 284	Refill: 10 classifier strips
405 000 285	Refill: 50 classifier strips

### SPECIAL CABINET KIT WITH NEUTRALISER FOR ACIDS, BASES, ACIDS & BASES

AIRBANK PRODUCT

CUSTOMIZABLE PRODUCT

Single-door polyethylene (PE) cabinet. Equipped with adjustable shelves.



CODE	DESCRIPTION	KIT AVERAGE ABSORPTION
405 004 199	SPECIAL cabinet kit with acid neutraliser 350 x 440 x h 980 mm	98 L (neutraliser depends on chemical substance)

CONTENTS: 100 pads, 3 socks, 1 mask, 1 pair of goggles, 1 chemical overall, 2 disposal bags, 1 dustpan + brush kit, 1 x 4.5 kg BASE NEUTRALIZER bag

405 004 201	SPECIAL cabinet kit with base neutralizer 350 x 440 x h 980 mm	98 L (neutraliser depends on chemical substance)
-------------	---	--

CONTENTS: 100 pads, 3 socks, 1 mask, 1 pair of goggles, 1 chemical overall, 2 disposal bags, 1 dustpan + brush kit, 1 x 4.5 kg BASE NEUTRALIZER bag

405 004 200	SPECIAL cabinet kit with acid and base neutraliser 350 x 440 x h 980 mm	16.5 L (neutraliser depends on chemical substance)
-------------	--	--

CONTENTS: 3 socks, 1 mask, 1 pair of goggles, 1 chemical overall, 2 disposal bags, 1 dustpan + brush kit, 1 x 4.5 kg ACID NEUTRALIZER bag, 4.5 kg BASE NEUTRALIZER absorbent product.

### SPECIAL UNI-SAFE BAG KIT

AIRBANK PRODUCT

CUSTOMIZABLE PRODUCT

Portable bag kit.



CODE	DESCRIPTION	KIT AVERAGE ABSORPTION
405 004 202	SPECIAL UNI-SAFE portable bag kit 400 x 400 x h 150 mm	60 L

CONTENTS: 10 pads, 3 socks, 1 mask, 1 pair of goggles, 1 chemical overall, 1 disposal bag, 1 dustpan + brush kit, 1 x 0.5 kg bottle of UNI-SAFE.

**CUSTOMISE YOUR KIT:** you can choose the absorbing material that best fits your needs  
**REFILL YOUR KIT:** you can order only the absorbing material and the PPE to refill the kit you already have

ON REQUEST

### SPECIAL TRANSPORT SECTOR KIT

 AIRBANK PRODUCT

 CUSTOMIZABLE PRODUCT



ADR bag kit for transporting dangerous goods in the indicated hazard classes. Every kit contains the obligatory equipment for "the vehicle" and "the driver".

CODE	DESCRIPTION	HAZARD CLASSES
405 003 175	SPECIAL dangerous goods transport kit 840 x 350 x h 370 mm	4.2 - 5.1 - 5.2 - 6.2 - 7

CONTENTS: 2 freestanding warning signs, 1 eyewash solution, 1 portable lamp, 1 pair of gloves, 1 pair of goggles.

405 003 176	SPECIAL dangerous goods transport kit 840 x 350 x h 370 mm	3 - 4.1 - 4.3 - 8 - 9
-------------	---	-----------------------

CONTENTS: 2 freestanding warning signs, 1 eyewash solution, 1 portable lamp, 1 pair of gloves, 1 pair of goggles, 1 shovel, 1 drain seal, 1 waste collection container.

### SPECIAL WIND-FARM SECTOR KIT

 AIRBANK PRODUCT

 CUSTOMIZABLE PRODUCT



405 003 299



405 003 300

Kit for wind-farm scheduled maintenance, composed of specially designed absorbent pads, absorbent socks, degreasing detergents for oils and the appropriate PPE in order to ensure maximum safety for operators. The kit also contains special bags for waste management.

CODE	DESCRIPTION	KIT AVERAGE ABSORPTION
405 003 299	SPECIAL mini emergency kit for wind farms 420 x 230 x h 370 mm	33 L

CONTENTS: 15 pads, 2 socks, 3 x 0.5 L SOBO QB (degreaser for fresh oils and greases), 2 disposal bags, 1 pair of goggles, 1 pair of gloves.

405 003 300	SPECIAL maxi emergency kit for wind farms 840 x 350 x h 370 mm	72 L
-------------	---	------

CONTENTS: 30 pads, 5 socks, 6 x 0.5 L SOBO QB (degreaser for fresh oils and greases), 2 disposal bags, 1 pair of goggles, 1 pair of gloves.

**CUSTOMISE YOUR KIT:** you can choose the absorbing material that best fits your needs  
**REFILL YOUR KIT:** you can order only the absorbing material and the PPE to refill the kit you already have

ON REQUEST



## 5 KIT FOR SPILLS OF SPECIAL LIQUIDS

### SPECIAL ENGINEERING SECTOR KIT

 AIRBANK PRODUCT

 CUSTOMIZABLE PRODUCT



Emergency kit for the mechanical engineering sector, in a 120 L container with castors composed of Oil Only pads and socks, specific absorbents for oils and the appropriate PPE in order to ensure maximum safety for operators. The kit also contains a bag for management of waste and stickers indicating the emergency and absorbent class of the waste.

CODE	DESCRIPTION	KIT AVERAGE ABSORPTION
405 003 347	SPECIAL emergency spill kit for the engineering sector 550 x 500 x h 940 mm	88 L

CONTENTS: 50 pads, 3 socks, 1 OKO-PUR PLUS bag, 2 disposal bags, 1 pair of goggles, 1 pair of gloves, 1 overall.

### SPECIAL FOOD SECTOR KIT

 AIRBANK PRODUCT

 CUSTOMIZABLE PRODUCT



Emergency kit for the food sector, in a 120 L container with castors composed of Universal pads and socks, specific absorbents and the appropriate PPE in order to ensure maximum safety for operators. The kit also contains a bag for management of waste and stickers indicating the emergency and absorbent class of the waste.

CODE	DESCRIPTION	KIT AVERAGE ABSORPTION
405 003 348	SPECIAL emergency spill kit for the food sector 550 x 500 x h 940 mm	67 L

CONTENTS: 50 pads, 3 socks, 1 STERILSORB bag, 2 disposal bags, 1 pair of goggles, 1 pair of gloves, 1 overall.

### SPECIAL CHEMICAL/PHARMA SECTOR KIT

 AIRBANK PRODUCT

 CUSTOMIZABLE PRODUCT



Emergency kit for the chemical/pharma sector, in a 120 L container with castors composed of Chem pads and socks, specific absorbents and the appropriate PPE in order to ensure maximum safety for operators. The kit also contains a bag for management of waste and stickers indicating the emergency and absorbent class of the waste.

CODE	DESCRIPTION	KIT AVERAGE ABSORPTION
405 003 349	SPECIAL emergency spill kit for the chemicals/pharma sector 550 x 500 x h 940 mm	132 L

CONTENTS: 50 pads, 3 socks, 1 STONE UNIVERSAL SORB bag, 2 disposal bags, 1 pair of goggles, 1 pair of gloves, 1 overall, 1 mask.

**CUSTOMISE YOUR KIT:** you can choose the absorbing material that best fits your needs  
**REFILL YOUR KIT:** you can order only the absorbing material and the PPE to refill the kit you already have

ON REQUEST

Pictures indicated in this catalogue are representative and not binding for the supplier in terms of layout and colours. They may be subject to changes by the supplier without prior notice.

### SPECIAL MARINE SECTOR KIT

 AIRBANK PRODUCT

 CUSTOMIZABLE PRODUCT



Emergency kit for boats and for the marine sector, in a 300 L container with feet composed of Oil Only pads and socks, dispersant for hydrocarbons (authorized by the Ministry of Environment for use at sea) and the appropriate PPE in order to ensure maximum safety for operators. The kit also contains a bag for management of waste and stickers indicating the emergency and absorbent class of the waste.

CODE	DESCRIPTION	KIT AVERAGE ABSORPTION
405 003 547	SPECIAL emergency spill kit for the marine sector 1000 x 700 x h 790 mm	308 L

CONTENTS: 50 pads, 8 socks, 5 kg dispersant for hydrocarbons, 2 disposal bags, 1 pair of gloves, 1 overall.

### OPA 90 SPECIAL



Specific kit compliant with OPA 90 (Oil Pollution Act of 1990) containing OIL ONLY absorbent material for recovery of spills at sea. The materials that make up the kit are placed in a container suitable for storage on ships, boats, offshore systems and therefore resistant to extreme environments. The kit contains pads, pillows, socks and rolls to absorb a spill of up to 7 barrels of crude oil (approximately 1381 L).

CODE	DESCRIPTION	KIT AVERAGE ABSORPTION
405 004 592	OPA90 kit - 7 barrels - "SPECIAL" PE container 1470 x 1000 x h 1040 mm	1381 L

CONTENTS: 750 pads, 8 pillows, 12 socks 7.6 x 120 cm, 12 socks Ø13 cm x 3 m, 1 paper towel roll, 5 pairs of gloves, 2 pair of goggles, 10 disposal bags, 5 overalls, 2 x 20 L buckets, 1 bilge pump, 2 non-sparking paddles, 2 plastic paddles.

CODE	DESCRIPTION	KIT AVERAGE ABSORPTION
405 004 593	OPA90 kit - 12 barrels - "SPECIAL" 2 x PE containers 1470 x 1000 x h 1040 mm	2251 L

CONTENTS: 950 pads, 16 pillows, 48 socks Ø 7.6 cm x 122 cm, 20 socks Ø 13 cm x 3 m, 1 paper towel roll, 5 pairs of gloves, 2 pair of goggles, 10 disposal bags, 5 overalls, 2 x 20 L buckets, 1 bilge pump, 2 non-sparking paddles, 2 plastic paddles.

**CUSTOMISE YOUR KIT:** you can choose the absorbing material that best fits your needs  
**REFILL YOUR KIT:** you can order only the absorbing material and the PPE to refill the kit you already have

ON REQUEST

Pictures indicated in this catalogue are representative and not binding for the supplier in terms of layout and colours. They may be subject to changes by the supplier without prior notice.

### SPECIAL SERIES NEUTRALISATION KIT FOR SULPHURIC ACID



#### Pipe for forklift trucks

Emergency response kits for forklifts and battery recharging and storage areas. Necessary for storage, recharging, maintenance and replacement of batteries. Contains absorbent and neutralising powder compliant with Decree No. 20 of 24 January 2011 issued by the Italian Environment Ministry.

CODE	DESCRIPTION	NEUTRALIZATION
405 000 201	SPECIAL sulphuric acid neutralization kit, pipe for forklift trucks - Ø 200 x h 1000 mm	2 L

CONTENTS: 20 pads, 2 socks, 1 Kg can of SOLFORLESS, 1 pair of gloves, 1 overall, 1 pair of goggles.



#### CARRY BAG for forklift trucks

Emergency response kits for forklifts and battery recharging and storage areas. Bag with full opening and Velcro closure. Straps for forklift attachment. Contains absorbent and neutralising powder compliant with Decree No. 20 of 24 January 2011 issued by the Italian Environment Ministry.

CODE	DESCRIPTION	NEUTRALIZATION
405 002 293	Sulphuric acid neutralizing kit, bag for forklift truck SPECIAL - Ø 100 x h 900 mm	3 L

CONTENTS: 2 x 1 Kg cans of SOLFORLESS, 1 overall, 1 pair of gloves, 1 pair of goggles, 1 safety mask.



#### TYPE APPROVED DRUM

Approved fully opening drum with removable lid containing neutralizing powder for the sulphuric acid contained in lead-acid batteries. These kits are customizable on request, according to the quantity of sulphuric acid to neutralize. Contains absorbent and neutralising powder compliant with Decree No. 20 of 24 January 2011 issued by the Italian Environment Ministry.

CODE	DESCRIPTION	NEUTRALIZATION
405 002 294	SPECIAL sulphuric acid neutralization kit, 60 L cylindrical container Ø 400 x h 620 mm	10 L

CONTENTS: 5 kg tub of neutralizing powder, 1 kg can of SOLFORLESS, 1 overall, 1 safety mask, 1 pair of goggles, 1 pair of gloves, 1 dustpan and brush, DGT approved bag, 1 bottle of eyewash solution.

405 002 295	Sulphuric acid neutralizing kit, 120 L cylinder container SPECIAL Ø 496 x h 800 mm	25 L
-------------	--	------

CONTENTS: 3 x 5 kg tubs of SOLFORLESS, 1 overall, 1 safety mask, 1 pair of goggles, 1 pair of gloves, 1 dustpan and brush, DGT approved bag, 1 bottle of eyewash solution.

**CUSTOMISE YOUR KIT:** you can choose the absorbing material that best fits your needs  
**REFILL YOUR KIT:** you can order only the absorbing material and the PPE to refill the kit you already have

ON REQUEST



### CARRY BAG

Carry bag with neutralizing powder for sulphuric acid of lead batteries. Contains absorbent and neutralising powder compliant with Decree No. 20 of 24 January 2011 issued by the Italian Environment Ministry.

CODE	DESCRIPTION	NEUTRALIZATION
405 002 296	Sulphuric acid neutralizing kit, SPECIAL bag 420 x 230 x h 370 mm	2 L

CONTENTS: 1 kg can of SOLFORLESS, 1 overall, 1 safety mask, 1 pair of goggles, 1 pair of gloves, 1 dustpan and brush, DGT approved bag, 1 Bottle of eyewash solution.



### CABINET

2-door polyethylene (PE) closet with castors, equipped with adjustable shelves, and containing neutralizing powder for accumulator sulphuric acid absorption. Contains absorbent and neutralising powder compliant with Decree No. 20 of 24 January 2011 issued by the Italian Environment Ministry. SPECIAL SERIES: for spills requiring special solutions.

CODE	DESCRIPTION	NEUTRALIZATION
405 003 592	SPECIAL sulphuric acid neutralising cabinet with castors kit 700 x 440 x h 980 mm	75 L

CONTENTS: 2 x 15 kg SOLFORLESS tubs, 2 x 5 kg SOLFORLESS tubs, 1 overall, 1 pair of goggles, 1 pair of gloves, 2 disposal bags, 1 mask.



### MOBILE STATION KIT

Mobile station kit w/bag, for indoor/outdoor use. Easy to assemble and disassemble. Ergonomic handles for ease of use. Solid rubber wheels (Ø 200 mm).

CODE	DESCRIPTION	KIT AVERAGE ABSORPTION
405 004 172	SPECIAL mobile station kit w/bag 580 x 595 x h 1725 mm	30 L

CONTENTS: 15 pads, 3 socks, 1 pair of gloves, 1 pair of goggles, 1 safety mask, 1 disposal bag, 1 X 15 kg bucket of SOLFORLESS and 1 eyewash kit.

\*product to be assembled

**CUSTOMISE YOUR KIT:** you can choose the absorbing material that best fits your needs  
**REFILL YOUR KIT:** you can order only the absorbing material and the PPE to refill the kit you already have

ON REQUEST

Pictures indicated in this catalogue are representative and not binding for the supplier in terms of layout and colours. They may be subject to changes by the supplier without prior notice.



## 5 EYEWASH STATIONS

### EYEWASH KIT



Eyewash station composed of 2 x 500 ml bottles of single-use 0.9% sterile saline solution with eye cap fitted for rapid use. Heat-moulded support with transparent front, dust-proof closure, internal mirror, screws and wall plugs for wall mounting.



CODE	DESCRIPTION
405 004 385	Eyewash kit • 40 x 30 cm

CONTENTS: 2 x 500 ml bottles sterile saline eyewash solution, 2 integrated eye cups, 1 mirror.

### WALL EYEWASH

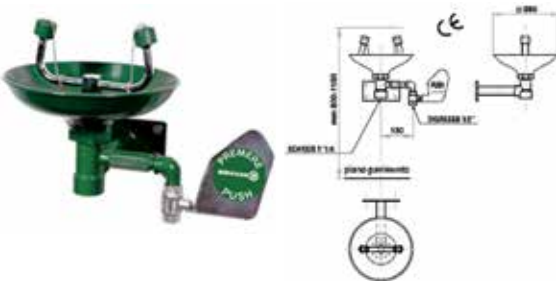

Eyewash with aerated flow, activated via manual shut-off valve with side push handle. Polypropylene (PP) tray, wall mounting.



CODE	DESCRIPTION
416 003 599	Wall eyewash

### EYEWASH STATION

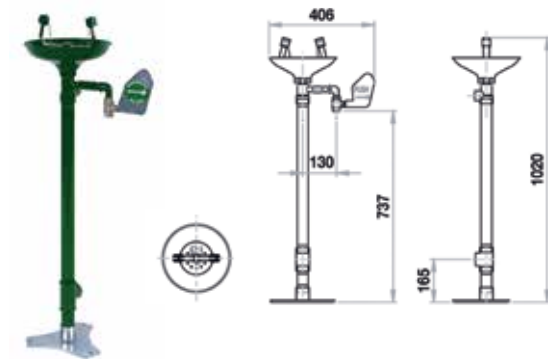

Eyewash with aerated flow, activated via manual shut-off valve with side push handle, green polypropylene (PP) tray, floor mounting.



CODE	DESCRIPTION
416 002 182	Eyewash station

### SHOWER AND EYEWASH COMBINATION

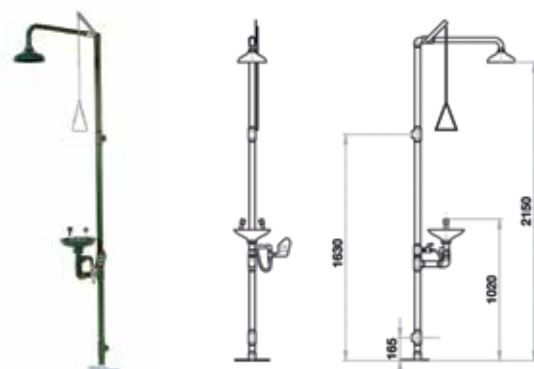

Combined shower and eyewash station, green polypropylene (PP) shower head, hand operated by rigid pull bar with triangular handle. Eyewash with aerated flow, complete with manual shut-off valve with side push handle, green polypropylene (PP) bowl.



CODE	DESCRIPTION
416 002 181	Shower and eyewash combination

## STAINLESS-STEEL PORTABLE PRESSURISED UNIT WITH SINGLE EYEWASH



Stainless-steel portable pressurised unit with single eyewash.

Capacity: 18 litres (max 15 L of potable water).

Operating pressure: 6 bar max. pressure.



CODE	DESCRIPTION	CAPACITY
405 003 931	Stainless-steel portable pressurised unit with single eyewash.	18 L

## REMOVABLE BENCH-MOUNTED SINGLE EYEWASH STATION



Emergency eyewash station for the installation of a work surface at low-pressure to high-pressure with deluge valve, manual push-button opening. RAL 6029 green. Suitable for industry, workshops, laboratories and more generally anywhere there is a risk of eye damage from fire, acids, reagents, petroleum-based products, radioactive material and any other pollutant.



CODE	DESCRIPTION
405 003 933	Removable bench-mounted single eyewash station

## REMOVABLE BENCH-MOUNTED DUAL EYEWASH STATION



Emergency dual eyewash system.

For high and low pressure. Installation of the work surface with deluge valve, manual push-button opening. Dual aerated jet with dust shield. RAL 6029 green.

Suitable for industry, workshops, laboratories and more generally anywhere there is a risk of eye damage from fire, acids, reagents, petroleum-based products, radioactive material and any other pollutant.



CODE	DESCRIPTION
405 003 932	Removable bench-mounted dual eyewash station









# PRODUCTS FOR LAND AND WATER SPILLS

	CONTAINMENT BOOMS FOR SEA SPILLS .....	page 88
6	FLOOD BOOMS.....	page 92
	OIL SKIMMERS.....	page 95
7	SAFETY GUARDS FOR DRAINS AND GRIDS.....	page 99



### RIGID CONTAINMENT BOOMS



High-strength floating booms designed for frequent use and exposure to degradation caused by both atmospheric agents and abrasion. It is the perfect floating boom for sheltered and calm water with weak currents and is recommended for oil refineries, general industry and environmental emergency teams.

#### FLOATS

Cylindrical flexible floats made of expanded technopolymers and filled with closed-cell foam. Float ends are finished at 45° angles to allow better boom mobility once it is deployed. The floats are sewn inside the upper pocket made of waterproof double layer fabric.

#### BALLAST CHAIN

Hot-galvanized chain inside a pocket within the double layer fabric of the boom.

#### ANCHORING SYSTEM

Mechanical clamp system made of Anticorodal aluminium, treated in suitable proportions with magnesium, copper and manganese to make it marine corrosion resistant. The system is supplied with AISI 316 stainless-steel quick connectors for easy boom deployment and retrieval in any situation.

To improve safety some replaceable zinc anodes are fitted on both couplings, in order to provide galvanic protection for longer life.

CODE	DESCRIPTION	MODULE DIMENSIONS
406 000 238	Rigid boom	h 450 mm x 10 m
406 000 239	Rigid boom	h 450 mm x 15 m
406 000 240	Rigid boom	h 450 mm x 20 m
406 000 241	Rigid boom	h 450 mm x 30 m

CODE	DESCRIPTION	MODULE DIMENSIONS
406 000 242	Rigid boom	h 660 mm x 10 m
406 000 243	Rigid boom	h 660 mm x 15 m
406 000 244	Rigid boom	h 660 mm x 20 m
406 000 245	Rigid boom	h 660 mm x 30 m



Pictures indicated in this catalogue are representative and not binding for the supplier in terms of layout and colours. They may be subject to changes by the supplier without prior notice.

# RIGID CONTAINMENT BOOMS WITH ANTI-JELLYFISH AND SEAWEED NET



High-strength floating booms designed for safeguarding bathing beaches from floating solids, oil and other hydrocarbons, sewage foam, mucilage and anything else which floats or remains at a depth of no more than 1.5 m in the water.

This also makes these booms ideal as jellyfish barriers.

They are made of a rigid floating part and a fine net below the water.

CODE	DESCRIPTION	MODULE DIMENSIONS
406 000 262	Rigid boom with net	h 1500 mm x 10 m
406 000 263	Rigid boom with net	h 1500 mm x 15 m
406 000 264	Rigid boom with net	h 1500 mm x 30 m

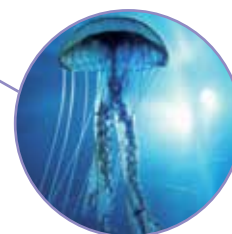
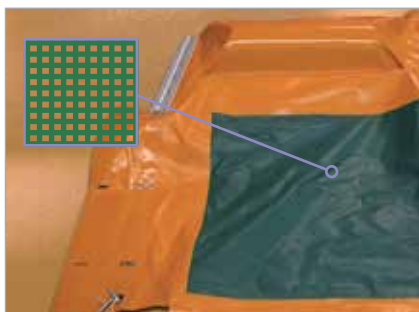

WATCH THE VIDEO



# MINI BOOMS



The same features as traditional rigid containment booms, but smaller, in order to be easily deployed in emergency situations.

Lightweight and easy to handle, they can also be used single-handed and are ideal for small spills in streams, canals and lakes.

Particularly useful for fire departments and emergency response teams, they can be easily transported in a normal pick-up truck and are quick and easy to assemble.

CODE	DESCRIPTION	MODULE DIMENSIONS
406 000 265	Mini Boom	h 200 mm x 7.5 m
406 000 266	Mini Boom	h 200 mm x 10 m
406 000 267	Mini Boom	h 200 mm x 20 m

Pictures indicated in this catalogue are representative and not binding for the supplier in terms of layout and colours. They may be subject to changes by the supplier without prior notice.

# CONTAINMENT BOOMS RIGID AND PERMANENT



These permanent rigid PVC booms with vertical elements in expanded polyethylene (PE) are ideal for separation in ports and calm water; they are ready to use, non-bulky and can be wound up on rolls. These materials allow for use both in high and low temperatures (-30°C - +70°C) without changing the booms' resistance to pollutants. These booms do not require maintenance, have ASTM connections in 6063 marine aluminium, lead ballast incorporated in the float and come in high-visibility ORANGE. Available also in the black polyurethane version, if you require an higher resistance to abrasion, puncturing and certain types of hydrocarbons.

CODE	DESCRIPTION	MODULE DIMENSIONS
406 003 090	Rigid permanent boom	h 600 mm x 10 m
406 003 091	Rigid permanent boom	h 800 mm x 10 m
406 003 092	Rigid permanent boom	h 1200 mm x 10 m

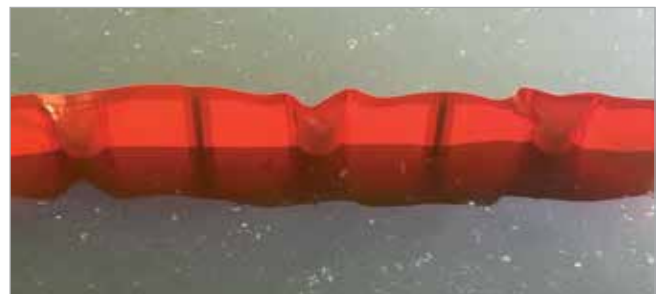

# INFLATABLE CONTAINMENT BOOMS



Ideal for use off-shore or where strong tides are likely. For use in emergency response operations, to dam harbours or docks, as protection barriers for oil loading and unloading areas as well as to protect tourist bathing beaches. The fabric composition makes the booms resistant to changes in temperature, elastic, and resistant to pollutants such as hydrocarbons and solvents. When not inflated the booms can be easily put on manual or motorized reeling rolls, to save space and allow them to be stowed on ships or in port areas; this way the booms are always ready for use in any emergency response situation. All inflatable booms are available in black or orange PU (subject to availability).

CODE	DESCRIPTION	MODULE DIMENSIONS
406 000 269	Inflatable boom	h 440 mm x 10 m
406 000 270	Inflatable boom	h 630 mm x 10 m
406 000 271	Inflatable boom	h 990 mm x 10 m
406 000 272	Inflatable boom	h 1250 mm x 10 m
406 000 273	Inflatable boom	h 1500 mm x 10 m
406 000 274	Inflatable boom	h 1800 mm x 20 m



Pictures indicated in this catalogue are representative and not binding for the supplier in terms of layout and colours. They may be subject to changes by the supplier without prior notice.



# SEMI-RIGID CONTAINMENT BOOMS



Semirigid containment booms consisting of a row of floats connected inside a rubberized nylon structure which makes them extremely strong. These materials allow for use both in high and low temperatures (-40°C - +90°C) without changing the booms' resistance to pollutants. It is also the ideal boom for harbours or calm water. The semirigid structure allows the boom to be positioned on manual or powered boom reels. Available in high-visibility orange, they can also be supplied in rubber, PU or PVC.

CODE	DESCRIPTION	MODULE DIMENSIONS
406 003 675	Semi-rigid boom	h 450 mm x 10 m
406 000 278	Semi-rigid boom	h 600 mm x 10 m
406 000 279	Semi-rigid boom	h 850 mm x 10 m
406 000 280	Semi-rigid boom	h 1150 mm x 10 m



Pictures indicated in this catalogue are representative and not binding for the supplier in terms of layout and colours. They may be subject to changes by the supplier without prior notice.





## POLYETHYLENE (PE) DOUBLE-TUBE BOOMS

New and advanced inflatable boom made of polyethylene (PE) to be used both on water and on land.

Easy and quick to deploy, the boom is delivered rolled on a reel allowing a quick roll-out procedure in emergency situations.

To use the boom on water you need only unroll the double-tube-boom to its intended length and close both ends with the caps. Fill the upper chamber with air, take to the water and then fill the lower chamber with water.

To use the boom on land just unroll the double-tube-boom to its intended length, close both ends with the caps and fill both chambers with water.

CODE	DESCRIPTION	MODULE DIMENSIONS
406 002 008	Set consisting of: • Inflatable boom • 2 clamps with 2" couplings • Uncoiling reel	150 m
406 002 009		300 m



## POLYETHYLENE (PE) DOUBLE-TUBE-BOOM DOOR SEALS

Our inflatable polyethylene (PE) door seals are the ideal solution for containing spills of dangerous substances, water and mud on work sites and in the event of flooding.

Just fill the boom with water using the Y-filling connection (on one side) which enables the 2-chambers to be filled simultaneously. Once filled, the boom will reach a maximum height of 35 cm.

CODE	DESCRIPTION	MODULE DIMENSIONS
406 002 297	Door seal	4 m
406 002 298		8 m
406 002 299		16 m



Pictures indicated in this catalogue are representative and not binding for the supplier in terms of layout and colours. They may be subject to changes by the supplier without prior notice.



# TUBEWALL



TUBEWALL is a self-anchoring mobile protective boom which provides protection against floods – it is able to stem standing or slow-flowing water up to a height of 100 cm. The modules can be connected together and even form corners in order to use the barrier as a water storage basin as well in emergencies. It can also be used to increase the height of existing banks or dykes, as well as making residential areas, buildings and streets safe.

It is light, safe and uses air, as the tube is a series of interconnected reinforced PVC tubes which are filled with air and the water necessary to keep them anchored to the ground. Not limiting itself to the weight of the tube for anchorage, the wall of the tube uses the weight of the flood water on a skirt present on one side of the tube only for a stable and safe hold. When the water starts rising, the skirt is held firmly on the ground, thanks also to a layer of anti-slip material underneath it, creating a water-tight seal and a fastening mechanism.

The tubes can be quickly and easily inflated with air using an electric inflater, and deflated just as easily using the same device. Each tube features 3 non-return valves for inflation, one on each end and one in the centre, making the operation particularly fast; as a matter of fact, it takes just 1.5 minutes to inflate a 10 m tube length (at approx. 7 kPa pressure).

A TUBEWALL boom weighs much less than a corresponding barrier made of sandbags, and can be easily positioned by 2 - 4 persons (2 people can position up to 100 m of TUBEWALL in less than an hour); it also works on grass, fields, dirt and asphalt roads, requiring minimal preparation of the site before installation.

TUBEWALL was developed in Sweden, with the support of the Swiss emergency services, and has been successfully used against numerous floods; the boom was awarded the Skapa prize in Sweden, and in December 2002 won first prize in the BBC's "best inventions" Live Show.

CODE	DESCRIPTION	MODULE DIMENSIONS
406 003 261	TUBEWALL	Ø 500 mm x 10 m
406 003 262	TUBEWALL	Ø 500 mm x 20 m
406 003 263	TUBEWALL	Ø 750 mm x 10 m
406 003 264	TUBEWALL	Ø 750 mm x 20 m
406 003 265	TUBEWALL	Ø 1000 mm x 10 m
406 003 266	TUBEWALL	Ø 1000 mm x 20 m



Pictures indicated in this catalogue are representative and not binding for the supplier in terms of layout and colours. They may be subject to changes by the supplier without prior notice.

### FLOODGATE



FLOODGATE is a quick and simple barrier system for doors and windows of industrial and residential buildings, to be used in the event of river flooding. It is composed of a 25 mm thick steel frame, with a 7 mm neoprene sheath wrapped around it; it expands telescopically on the horizontal and vertical planes to simply and safely adapt to a wide range of door frames. Thanks to its unique design, FLOODGATE does not have permanent connections to the frame it is fastened to, leaving it intact when removed. Once expanded, FLOODGATE guarantees a watertight seal between the inside and outside of the building, and provides more effective protection than over 50 sandbags. It takes just 2 minutes to position, eliminating installation costs and wasted time for inspections. FLOODGATE modules can be joined both vertically and horizontally using the dedicated connection systems.

CODE	DESCRIPTION	MODULE DIMENSIONS
406 003 254	FLOODGATE XS	650 - 880 x h 680 mm
406 003 255	FLOODGATE Standard	750 - 980 x h 680 mm
406 003 256	FLOODGATE Regular	870 - 1100 x h 680 mm
406 003 257	FLOODGATE Medium	955 - 1185 x h 680 mm
406 003 258	FLOODGATE Large	1175 - 1405 x h 680 mm
406 003 259	FLOODGATE XL	1350 - 1580 x h 680 mm
406 003 260	FLOODGATE XXL	1520 - 1660 x h 680 mm
406 004 643	FLOODGATE connection mod. XXL	
406 004 642	FLOODGATE connection mod. L - XL	
406 004 641	FLOODGATE connection mod. Regular M	
406 004 640	FLOODGATE connection mod. XS - Standard	



WATCH THE VIDEO



Pictures indicated in this catalogue are representative and not binding for the supplier in terms of layout and colours. They may be subject to changes by the supplier without prior notice.





# DRUM SKIMMER



The DRUM SKIMMER is a floating system designed to recover oil products on the surface of the water.

Designed for cleaning up oil spills at sea, it is also ideal for recovering oily liquids floating in industrial sumps and tanks without using solvents or other chemicals.

Its special design allows it to be used in rough seas, with the aid of floating booms to contain the spill.

It functions in as little as 20 cm of water and is unsinkable. The construction materials are resistant to salt water and corrosive chemicals. The plastic frame features a tubular shape, where oily materials recovered by rotating brush wheels are collected to be sent to a recovery tank.



## STRONG POINTS

- Easy to transport
- High recovery rate
- Can operate in calm and heavy seas, and with debris
- Easy to dismantle brush wheels and pump
- Recovers petroleum products, vegetable oils and oily chemical substances

## APPLICATIONS

- Refineries
- Fuel deposits
- Iron and steel industries
- Tourist ports
- Tankers
- Harbour and sea clean up
- Maintenance facilities, car washes and workshops
- First flush water treatment equipment

## FEATURES

- Equipped with removable HDPE floats and lifting handles
- Full plastic construction of the frame and the brush wheel
- Dry compressed air or hydraulic power supply
- Patented, with CE marking
- 1 1/2" F coupling for suction mouth connection
- With control panel
- Connecting suction tube available on request

CODE	DESCRIPTION	HYDROCARBON RECOVERY RATE
406 002 269	Drum skimmer with pump on board • 945 x 990 x h 500 mm	3 m <sup>3</sup> /h
406 002 270	Drum skimmer with pump on board • 1100 x 1000 x h 550 mm	5 m <sup>3</sup> /h
406 002 271	Drum skimmer with pump on board • 1570 x 1200 x h 700 mm	10 m <sup>3</sup> /h



WATCH THE VIDEO



Pictures indicated in this catalogue are representative and not binding for the supplier in terms of layout and colours. They may be subject to changes by the supplier without prior notice.



### SELECTIVE SKIMMER



The SELECTIVE SKIMMER is a floating system which can clean the water surface of oil and hydrocarbons thanks to the hydrophobic properties of the bristles making up its brush. It is composed of materials which are not altered by contact with seawater or corrosive chemicals.

This device is particularly useful for all types of recovery of hydrocarbons on the sea, rivers and lakes, with a recovery rate of 5 m<sup>3</sup>/hour. This compact and light yet extremely solid and stable system is connected to a pump for emptying the tank. The skimmer recovers floating substances without the use of solvents or other chemical products to clean pollutants from the water surface.

#### STRONG POINTS

- Particularly suitable for recovery of viscous oils and sludge
- Can be connected to any kind of pumping system present
- Can operate on both calm and heavy seas
- Compact, light and easily transported
- Made of aluminium and stainless steel, making it long lasting and easy to clean

#### APPLICATIONS

- Refineries
- Fuel deposits
- Iron and steel industries
- Tourist ports
- Tankers
- Harbour and sea clean up
- Maintenance facilities, car washes and workshops

#### FEATURES

- Dimensions: 860 x 590 x h 424 mm
- Weight: 20 kg (without pump)
- Motor: pneumatic
- Floating points: 4
- Float material: Polyethylene (PE)
- Frame: Aluminium 5754, stainless steel
- Brush: PP bristles
- Rotation speed: 60 rpm
- Min. usage depth: 167 mm

CODE	DESCRIPTION	HYDROCARBON RECOVERY RATE
406 002 670	Selective skimmer with on-board pump • 860 x 590 x h 424 mm	5 m <sup>3</sup> /h



Pictures indicated in this catalogue are representative and not binding for the supplier in terms of layout and colours. They may be subject to changes by the supplier without prior notice.



# DISC SKIMMER



The DISC SKIMMER is a compact, lightweight and portable system which uses a set of aluminium discs threaded onto an axis perpendicular to the water to facilitate recovery of floating oils and hydrocarbons. The discs, which feature a hydrophobic surface (and therefore do not retain water), recover the pollutant via a rotary motion; this is then directed into an adjoining tank with a scraper; at the same time, the oil is sucked off by a pump and transferred into a tank on the vessel or on the ground. The connection between the Skimmer and the tube for the pumping system uses a Camlock connection; the Skimmer is also equipped with a control panel for pneumatic regulation. All materials used are resistant to the marine environment and contact with hydrocarbons and other pollutants. The oil recovery capacity is around 8 m<sup>3</sup>/h, leaving the water 98% clean.



## STRONG POINTS

- Recovery of a high quantity of oils thanks to the large surface area of the discs
- Particularly suited for recovery of emulsified oil and in the presence of foams
- Can be connected to any kind of pumping system present
- Compact, light and easily transported
- Made of aluminium and stainless steel, making it long lasting and easy to clean

## APPLICATIONS

- Refineries
- Fuel deposits
- Iron and steel industries
- Tourist ports
- Tankers
- Harbour and sea clean up
- Maintenance facilities, car washes and workshops
- First flush water treatment equipment

## FEATURES

- Dimensions: 860 x 590 x h 424 mm
- Weight: 22 kg (without pump)
- Motor: pneumatic
- Floating points: 4
- Float material: Polyethylene (PE)
- Frame: Aluminium 5754, stainless steel
- PVC discs
- Rotation speed: 60 rpm
- Min. usage depth: 167 mm

CODE	DESCRIPTION	HYDROCARBON RECOVERY RATE
406 003 270	Disc skimmer with on-board pump • 860 x 590 x h 424 mm	5 m <sup>3</sup> /h



Pictures indicated in this catalogue are representative and not binding for the supplier in terms of layout and colours. They may be subject to changes by the supplier without prior notice.

## SPECIAL PRODUCTS

Alongside the products offered in our catalogue, Airbank offers custom design and manufacture of products to meet specific customer requirements.

**This process, performed in a professional and flexible manner by Airbank, consists of three stages:**

- Visit to the customer premises to perform analysis of key issues
- Detailed design to come up with the best product
- Final testing to ensure the project meets the customer's requirements

Here are some examples of special products developed by Airbank:

### COMPACT SEMI-RIGID CONTAINMENT BOOMS



### HIGH-VISIBILITY FLOATING BOOMS FOR PROTECTING SENSITIVE AREAS



### RIGID CONTAINMENT BOOMS

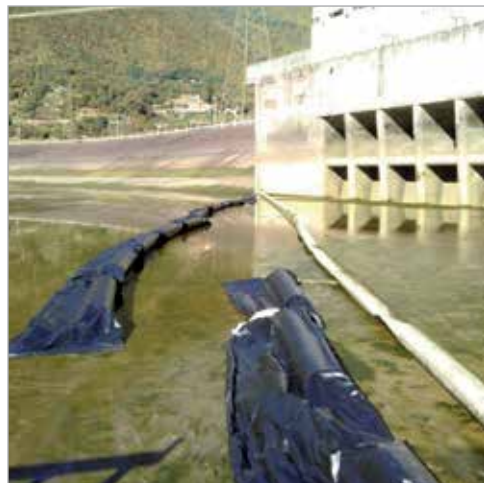

**WATCH  
THE VIDEO**







# HIGH VISIBILITY DRAIN COVERS

Used to prevent pollution from escaping down the drain, they are resistant to water, hydrocarbons and to the most corrosive chemicals.

Easy to use in emergency situations, requiring only laying over the manhole. It adheres perfectly to uneven or sandy ground.

Made of high-quality polymers which make it strong and flexible.

After use it only requires washing before it is ready to be used again.

**N.B.:** can be used for equipment present on board transport vehicles, per ADR (DGT) regulations

CODE	DESCRIPTION	THICKNESS
407 000 286	Green drain seal • 46 x 46 cm	1.3 cm
407 000 287	Green drain seal • 61 x 61 cm	1.3 cm
407 000 288	Green drain seal • 91 x 91 cm	1.3 cm
407 000 289	Green drain seal • 120 x 120 cm	1.3 cm
407 000 290	Green drain seal • 300 x 100 cm	1.3 cm

## TRANSPORT OF HAZARDOUS GOODS: ADR REGULATIONS

### 8.1.5 Miscellaneous equipment and personal protective equipment

#### 8.1.5.2 The following equipment shall be carried on board the goods transport vehicle:

- For each vehicle, a wheel chock of a size suited to the maximum mass of the vehicle and to the diameter of the wheel
- Two freestanding warning signs
- Eyewash

#### For each member of the vehicle crew:

- A high-vis safety vest (e.g. as described in the EN 471 standard)
- Portable lighting apparatus conforming to the provisions of 8.3.4
- A pair of protective gloves
- Eye protection (e.g. protective goggles)

#### 8.1.5.3 Additional equipment required for certain classes:

- An emergency escape mask for each member of the vehicle crew shall be carried on board the vehicle for danger label numbers 2.3 or 6.1
- A shovel\*
- **A drain seal\***
- A collection container\*

(\* Only required for danger label numbers 3, 4.1, 4.3, 8 and 9)

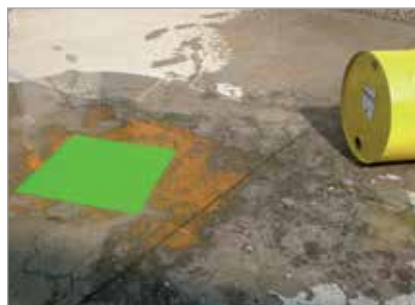

Perfect adherence even on uneven ground.

Pictures indicated in this catalogue are representative and not binding for the supplier in terms of layout and colours. They may be subject to changes by the supplier without prior notice.





## “ECO” SERIES HIGH-VISIBILITY DRAIN COVERS



Used to prevent pollution from escaping down the drain, it is resistant to water, hydrocarbons and to the most corrosive chemicals. Easy to use in emergency situations, requiring only laying over the manhole. It adheres perfectly to uneven or sandy ground. Made of high-quality polymers which make it strong and flexible. After use it only requires washing before it is ready to be used again.

“Eco” series manhole covers are high-visibility orange.

**N.B.:** can be used for equipment present on board transport vehicles, per ADR (DGT) regulations

CODE	DESCRIPTION	THICKNESS
407 003 048	Orange drain seal • 46 x 46 cm	0.8 cm
407 003 049	Orange drain seal • 61 x 61 cm	0.8 cm
407 003 050	Orange drain seal • 91 x 91 cm	0.8 cm
407 003 051	Orange drain seal • 120 x 120 cm	0.8 cm



## ROLL-CARRIER BOXES AND BAGS



### ROLL-CARRIER BOX

Metal case for drain seals, fitted with safety glass made of accident-proof resin which can be broken by pressure when required, and a hinged hatch with security lock. Can be wall mounted.

### ROLL-CARRIER BAG

Bag made of high-visibility yellow heavy nylon with identification printing. Slide closure allows the bag to be hung in areas at risk of a spill.

CODE	DESCRIPTION	DIMENSIONS
407 000 291	Roll-carrier box	330 x 280 x h 610 mm
407 000 292	Roll-carrier box	320 x 245 x h 810 mm
407 000 294	Roll-carrier bag	Ø 200 x h 800 mm
407 000 296	Roll-carrier bag	Ø 250 x h 1300 mm

## FLEXIBLE DIKES



Flexible, triangular berm to seal off or deviate accidental spills without absorbing them. Adheres perfectly to the ground even when uneven.

Made of rubberised technopolymer, it is resistant to oils, hydrocarbons and most chemicals. Easily cleaned for repeated use.

In high-visibility iridescent green; 45° slant means further joints are not required.



CODE	DESCRIPTION	DIMENSIONS
407 000 297	Open flexible dyke	50 x 2000 x h 45 mm
407 000 298	Open flexible dyke	100 x 3000 x h 70 mm
407 000 299	Ring flexible dyke	50 x Ø 450 x h 45 mm



## RIGID DIKES



These dykes are designed to protect spills of hazardous substances or water leakages permanently or temporarily simply by fixing them to the pavement with silicone or screw anchors (standard version) or simply by resting them on a clean surface in the version with adhesive rubber.

These dykes are made of polyurethane, and have a good resistance to abrasion, water, hydrocarbons, oils and to a series of aggressive chemical agents. Resistant to temperatures from -30°C to +100°C.

CODE	DESCRIPTION	DIMENSIONS
407 003 052	Standard rigid dyke	100 x 1500 x h 60 mm
407 003 053	Rigid dyke with nonwoven fabric reinforcement and adhesive rubber	100 x 1500 x h 60 mm
407 003 054	Joint for dyke	120 x 100 x h 60 mm
407 003 055	Corner for standard rigid dyke	100 x 370 x h 60 mm
407 003 114	Corner for rigid dyke with nonwoven fabric reinforcement and adhesive rubber	100 x 370 x h 60 mm



Pictures indicated in this catalogue are representative and not binding for the supplier in terms of layout and colours. They may be subject to changes by the supplier without prior notice.





# INDUSTRIAL CLEANING PRODUCTS

8	DEPOLLUTANTS AND DETERGENTS FOR INDUSTRIAL CLEANING .....	page 104
9	BIODEGRADABLE AND BIOLOGICAL PRODUCTS .....	page 114



## HIDRO CARBON SOLVENT



### Hydrocarbon break-up solution

HCS (Hidro Carbon Solvent) is a hydrocarbon neutralizing solution which effectively mitigates the environmental impact of these compounds.

HCS acts on the hydrocarbon surface tension, breaking the hydrogen and carbon molecular chain. Once these elements have been divided they are made "bio-available". This means that in just a few minutes HCS can decompose hydrocarbons on the surface.

### STRONG POINTS

- Flammability of the hydrocarbons is nearly nullified
- Eliminates all traces of hydrocarbons
- Contaminants rendered chemically inert

### APPLICATIONS

- Cleaning hulls and bilges
- Washing tanks
- Washing refinery systems
- Cleaning of tankers and tanks

### FEATURES

- Quick-acting concentrate
- Non-flammable
- Not affected by freezing temperatures
- Instantly eliminates volatile organic compounds
- Improves natural decomposition of hydrocarbons

**HCS - Foam:** for vertical surfaces or where gripping and lasting foaming is required.

CODE	DESCRIPTION	PACKAGING
408 000 304	HCS foam break-up solution	10 L jerrycan
408 000 305		25 L jerrycan
408 000 306		210 L drum

**HCS - Hidro Carbon Solvent:** Surfactant liquid.

CODE	DESCRIPTION	PACKAGING
408 000 300	HCS break-up solution	10 L jerrycan
408 000 301		25 L jerrycan
408 000 302		210 L drum



Washing of tankers



Washing of underground tanks



Washing of refinery systems

# CHIMSPERSE 4000



### Dispersant for decontamination of marine waters polluted by oil

CHIMSPERSE 4000 is a next-generation dispersant specifically formulated for cleaning sea areas contaminated by hydrocarbons. Its use fragments crude oil into very fine droplets, enormously assisting in its degradation by the micro-organisms naturally present in the sea. In both calm or rough seas, spray on the water surface with appropriate spray arms or similar. The product requires dilution with water. CHIMSPERSE 4000 is totally biodegradable and is non-toxic for marine flora and fauna, as certified by an accredited independent laboratory; it has also passed tests for dispersant-emulsifier effectiveness, biodegradability, and toxicity for seaweed, crustaceans and fish, as required by the Italian ministry for the environment, and has received the corresponding official approval for use at sea.



### STRONG POINTS

- 80% biodegradable
- The toxicity for marine fauna and flora is within the range specified by the Italian Ministry for the Environment
- Easy to use
- Effective both in calm and heavy seas

### APPLICATIONS

- Cleaning sea areas contaminated by hydrocarbons
- Cleaning rocks and cliffs
- Cleaning beaches
- Cleaning hulls, bilges and metal parts of boats
- Use in inland bodies of water must be assessed and approved in advance by the supervisory body concerned

### FEATURES

- Colourless to yellow-amber liquid
- Odourless
- Non-flammable
- Requires dilution with water (fresh or salt)
- No hazard class applicable for transport

CODE	DESCRIPTION	PACKAGING
408 001 027	Dispersant for hydrocarbons CHIMSPERSE 4000	5 Kg jerrycan
408 001 028		10 Kg jerrycan
408 001 029		55 Kg jerrycan
408 001 030		200 Kg drum

### MECHANISM OF DISPERSION IN TREATMENT OF OIL SLICKS

- The dispersant is sprayed on to the oil as droplets. The dispersant contains surfactants, made up of two parts: an oleophilic part (oil-loving) and a hydrophilic part (water-loving) capable of emulsifying the hydrocarbons in water while liberating the water included in the oil slick.
- The emulsion of oil in water which is formed disperses the hydrocarbons in small droplets, favouring their degradation by naturally occurring bacteria.
- The emulsified oil in the form of small droplets does not inhibit oxygen-water exchange, and the oil droplets treated with the surfactants which attach to their surface no longer affect the surfaces they come into contact with. The dispersant can also be used as a cleaner of the surfaces made dirty by the oil spill.

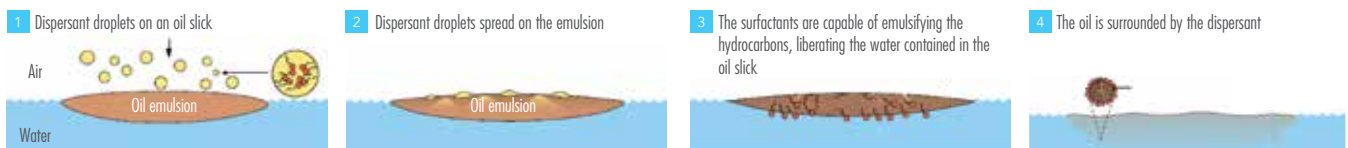

Pictures indicated in this catalogue are representative and not binding for the supplier in terms of layout and colours. They may be subject to changes by the supplier without prior notice.



## OT8

### Biological remover for solid and liquid hydrocarbon residues

OT8 is a viscous liquid that contains a blend of biological enzymes and bacteria to fully digest oil spills. Its enzymes degrade all hydrocarbon molecules into H<sub>2</sub>O and CO<sub>2</sub>, leaving no harmful residue.

#### STRONG POINTS

- Easy to use, it does not damage any kind of surface
- Non-hazardous
- Removes oil and hydrocarbon stains
- Non-corrosive
- A litre of OT8 is sufficient to clean 1 - 2.5 m<sup>2</sup> depending on surface porosity.

WATCH THE VIDEO



#### APPLICATIONS

- Cleaning paved surfaces
- Cleaning tankers
- Cleaning of any washable surface

#### FEATURES

- Composition: enzymatic liquid
- Colour: white and brown layered liquid
- Citrus perfume, water-soluble

CODE	DESCRIPTION	PACKAGING
408 000 327	Biological remover for OT8 hydrocarbons	12 x 1 L bottles
408 000 328		4 x 5 L jerrycans
408 000 326		20 L jerrycan



## BIO TA

### Biological liquid for removing oil and hydrocarbon stains from asphalt

BIO TA is a viscous liquid that contains a blend of biological enzymes and bacteria to fully digest all kinds of oil and hydrocarbon spills on asphalt.

Note: Not suitable for removing of synthetic oils, hydraulic fluids and wood oils.

#### STRONG POINTS

- Easy to use
- Does not damage the road surface
- Environmentally friendly
- Non-hazardous
- Removes oil and hydrocarbon stains
- Non-corrosive

#### APPLICATIONS

- Car parks
- Roads
- Concrete surfaces

#### FEATURES

- Composition: organic liquid
- Colour: white and brown layered liquid

CODE	DESCRIPTION	PACKAGING
408 004 882	Biological liquid for removing oil and hydrocarbon stains from asphalt - BIO TA	20 L jerrycan
408 004 883		4 x 25 L jerrycans



## ROAD BIO

### Asphalt oil stain remover

Oil and diesel spills on road surfaces are very dangerous and need to be contained immediately and effectively, above all on permeable asphalts. ROAD BIO can be used on the spill with dilution rates from 20 to 50%.

#### STRONG POINTS

- Quickly removes and digests hydrocarbons spills
- Non-flammable
- Enzyme-based product with specific bacteria for oil
- 1 L ROAD BIO cleans 1,5 - 3,5 m<sup>2</sup> surface

#### APPLICATIONS

- Petrol stations
- Motorways
- Car parks
- Scrapyards

#### FEATURES

- Appearance: Liquid
- Colour: Straw yellow
- Density 1.07 kg/dm<sup>3</sup>
- Relative density 1.06

CODE	DESCRIPTION	PACKAGING
408 000 338	ROAD BIO hydrocarbon remover for asphalt	4 x 5 L jerrycans
408 000 339		20 L jerrycan
408 000 340		200 L drum



WATCH THE VIDEO







## BIO TUBE

### Enzyme tube

Enzyme tube which absorbs and digests 2 kg of hydrocarbons a week for 6-8 months, turning it into CO<sub>2</sub> and H<sub>2</sub>O. Fitted with connecting cable.

#### STRONG POINTS

- Digests and reduces oil volume
- Helps minimize oil discharge risks
- Reduces BOD and COD levels.
- Separates oil from water

#### APPLICATIONS

- Septic tanks
- Carwash manholes
- Industry
- Oil skimmers

CODE	DESCRIPTION	PACKAGING
408 000 329	BIO TUBE enzyme tube • Ø 29 x 50 cm	3 piece/box
408 000 330	BIO TUBE enzyme tube • Ø 29 x 50 cm	6 piece/box



## SOBO QB

### Degreaser for Oil and fresh greases

A degreaser ideal for removal of oils and fresh greases from dirty surfaces, to be used pure or diluted. SOBO QB can be wiped over the stain and must be rinsed off immediately. Unlike other detergents, it does not require vigorous brushing by hand or cleaning machines and does not produce foam. Helps oil-water separation in sumps or separators. Can be used as supplied or diluted up to 1:50.

#### APPLICATIONS

- Car parks
- Railway stations
- Petrol stations
- OFF-SHORE platforms
- Scrapyards
- Hydroelectric systems
- Separators/oil skimmers

#### STRONG POINTS

- Fast acting
- Degreases on contact, immersion or spray
- Ideal to remove oil and fat from industrial systems (e.g. hydroelectric systems)

CODE	DESCRIPTION	PACKAGING
408 000 335	SOBO QB degreaser for fresh oils	25 L jerrycan
408 000 336		200 L drum

WATCH THE VIDEO





### TANKSHINE

 AIRBANK PRODUCT

#### Degreasing solvent

TANKSHINE is a strong, highly-concentrated and powerful degreasing solvent. This product is able to remove heavy oil and grease stains, and it is a fast and efficient cleanser to remove hydrocarbon residues from storage tanks, walls and floors. It efficiently removes asphaltenes, crude oil, bitumen, hardened fat and dirt. TANKSHINE is more environmentally-friendly compared to other products available on the market. Furthermore, the product is free from volatile organic compounds (VOC) and it is not flammable. Dilute the product in water based on the lever of dirt; this also makes the product more cost-effective, compared to standard cleansers.



#### APPLICATIONS

- Tanks
- Piping
- Floors

#### STRONG POINTS

- Strong degreasing power
- High flash point
- Cost-effective - diluted with 4-10% of water
- Removes hydrocarbon residues
- Free from D-Limonene and VOC

CODE	DESCRIPTION	PACKAGING
408 003 501	TANKSHINE degreasing solvent	25 L jerrycan



### POLYLESS

 AIRBANK PRODUCT

#### Polyelectrolyte stain remover

Polyelectrolytes are polymers used as:

- thickeners for cosmetic products, soap, paints, food products etc.,
- dispersants in clay suspensions, paint pigments, drilling muds etc.
- flocculants in water treatment
- In the textile industry (in gluing, dyeing, finishing operations)
- In ion exchange resin or membrane preparation

POLYLESS is a solvent able to remove polyelectrolyte residue from industrial flooring.



#### APPLICATIONS

- Cosmetics, food, manufacturing industries
- Textile industry
- Paint manufacturers
- Water treatment plants

#### STRONG POINTS

- Easy to use
- Easy to wash after use
- Rapidly removes encrustations from flooring, stopping them becoming slippery

CODE	DESCRIPTION	PACKAGING
408 002 403	POLYLESS polyelectrolyte stain remover	25 L jerrycan

Pictures indicated in this catalogue are representative and not binding for the supplier in terms of layout and colours. They may be subject to changes by the supplier without prior notice.



## MECHCLEAN

AIRBANK PRODUCT

### Specific degreaser for the mechanical industry

MECHCLEAN is a water-based degreaser ideal to remove grease and oil stains, free from VOC and solvents.

Designed to be used in washing tanks and ultrasound systems, MECHCLEAN leaves the surfaces clean and free from oil. Dilute by 2-5% depending on how soiled the surface is and on the required corrosion inhibition properties.



### APPLICATIONS

- Machining sector
- Industry
- Washing basins
- Machine tools

WATCH THE VIDEO



### STRONG POINTS

- Rust inhibitor
- VOC free
- It leaves the surfaces clean and free from oil and grease residues

CODE	DESCRIPTION	PACKAGING
408 003 663	Specific degreaser for the mechanical industry MECHCLEAN	4 x 5 L jerrycans
408 003 664		25 L jerrycan



## FLOORCLEAN

AIRBANK PRODUCT

### Degreaser and deodorizer for industrial floors

FLOORCLEAN is an efficient degreaser that also removes the odours.

It efficiently removes stains and residues from lubricant oils, coolants, cutting oils, etc. from industrial floors.

A mix of biodegradable surfactants, FLOORCLEAN is a water-based non-emulsifiable degreaser ideal also for floor washers. Use diluted by 4-6%. Dilutions under 1:2 are not classified as hazardous.

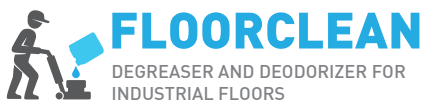

### APPLICATIONS

- Industry
- Floor washers
- Workshops

WATCH THE VIDEO



### STRONG POINTS

- Biodegradable
- High degreasing and deodorizing power
- Low VOC content
- With a dilution under 1:2, the product is not hazardous

CODE	DESCRIPTION	PACKAGING
408 003 661	FLOORCLEAN degreaser and deodorizer for industrial floors	4 x 5 L jerrycans
408 003 662		25 L jerrycan



## E-NOX SHINE



### Water-based cleanser

A new, special and high-performing water-based product to clean and maintain polished and satin stainless steel. It removes dust, fingerprints, oil, light lime build-up and superficial oxidation from polished and satin stainless steel; it can also be used to maintain aluminium, chromed surfaces, ceramics, wood, non-ferrous metals, glass and plastics. It dries fast on treated surfaces, leaving a shiny protective film with an excellent resistance. Dirt repellent and antistatic. It does not ruin printed or etched labels (e.g. on kitchen appliances and elevators).

### APPLICATIONS

- Cafeterias
- Kitchens
- Appliances
- Stainless-steel surfaces

WATCH  
THE VIDEO



### STRONG POINTS

- *Silicone free*
- *Ready to use*
- *VOC free*

CODE	DESCRIPTION	PACKAGING
408 003 693	Water-based cleanser E-NOX SHINE	10 L jerrycan
408 003 694		20 L jerrycan



## UNO SF



### Intense cleanser

Low-foaming water-based cleanser. Highly concentrated and alkaline. Ideal to remove oils and mineral fats, protein residues, separating agents, smoke and wax residues, fresh paint and pigmented ink residues.

Do not use the product on aluminium and/or galvanized surfaces without diluting it.

### APPLICATIONS

- Industrial kitchens
- Plastic materials sector
- Printing companies
- Lithographic plants

### STRONG POINTS

- *Non-flammable*
- *VOC reduced*
- *Ideal for mechanical and manual cleansing*
- *Phosphate-free*

CODE	DESCRIPTION	PACKAGING
408 003 692	UNO SF intense cleanser	20 L jerrycan

The NSF (National Sanitation Foundation) is a US-based non-profit involved in public health and environmental protection. Among other activities, it gives **awards to products which are not harmful when used in contact with foodstuffs, water or air**. As well as product performance, the design and construction quality, as well as the safety of the material, are assessed.





**GRAFFLESS®**  
GRAFFITI REMOVAL GEL

### APPLICATIONS

- All kinds of natural stone
- Bricks
- Concrete
- Concrete blocks
- Roadsigns
- Railway wagons

## GRAFFLESS

AIRBANK PRODUCT

### Graffiti remover gel

The innovative product GRAFFLESS is a gelatinous cleaning product for cleaning spray paint from surfaces.

The product is applied as-is to the vandalized surface. Its consistency allows it to grip the surface, and after just 10-15 minutes it can be removed with running water, pressure-washer, abrasive fabric or stiff-bristle brush. The quantity required will depend on the surface porosity and roughness, but as an approximate guide allow for 100 to 200 g/m<sup>2</sup>.

### STRONG POINTS

- Sustainable technology
- Reduced cleaning costs
- Easy to use
- Fast acting
- Non-flammable

CODE	DESCRIPTION	PACKAGING
408 002 804	GRAFFLESS graffiti remover gel	6 Kg jerrycan
408 002 805		30 Kg jerrycan

WATCH THE VIDEO



**KEEP CLEAN**  
**GRAFFLESS®**  
ANTI-GRAFFITI BARRIER

### APPLICATIONS

- All kinds of natural stone
- Bricks
- Concrete
- Concrete blocks
- Painted renders (resistant to hot high-pressure washing)
- Granite
- Marble

## GRAFFLESS KEEP CLEAN

AIRBANK PRODUCT

### Anti-graffiti barrier

The innovative GRAFFLESS KEEP CLEAN is a protective anti-graffiti barrier to be applied to walls and other surfaces to protect them against spray-can graffiti.

The product is based on an aqueous emulsion of modified organic polymers. It is ready to use and can be applied by brush, roller or airless spray; the surface to be treated must be cleaned and dry before application.

GRAFFLESS KEEP CLEAN fills the pores of the treated surface, forming an invisible protective film without impeding breathability – a real oil-, water- and graffiti-proof barrier. The quantity required will depend on the surface porosity and roughness, but as an approximate guide allow for 50 to 150 g/m<sup>2</sup>; drying time is approximately 20 minutes at 20°C.

### STRONG POINTS

- Sustainable technology
- Reduced cleaning costs
- Easy to use
- Fast acting
- Non-flammable

CODE	DESCRIPTION	PACKAGING
408 002 806	GRAFFLESS KEEP CLEAN anti-graffiti barrier	5 L jerrycan
408 002 807		25 L jerrycan

WATCH THE VIDEO



## SANITIZING DISINFECTANT CLEANERS



Disinfectant formulated by combining the excellent disinfecting power of quaternary ammonium salt with the synergistic strength of EDTA, monoethanolamine and a non-ionic surfactant with strong cleaning properties; it reduces cleaning and disinfection of surfaces and equipment to a single step. It is non-corrosive and acts on both gram + and gram - bacteria and fungi. It is ready to use, cleans and disinfects quickly, leaves no odours or halos and is easy to rinse.

CODE	DESCRIPTION	PACK
408 004 460	UPS sanitizing disinfectant cleaner	Box with 8 x 750 ml bottles
408 004 461	UPS sanitizing disinfectant cleaner	1 x 750 ml bottle



Cleaning disinfectant with citrus fragrance, ready to use for surfaces at risk of contamination. Self-drying detergent for bacteria (both Gram+ and Gram-) fungi and virus control. It can be used to protect any washable surface from the risk of contamination. It is used in the health-care and civil sectors for the daily disinfection of furnishings, toilets, windows and surfaces in general. It is a medical-grade product (USP) registered with the Ministry of Health. **It is a CAM compliant product with EPD certified environmental performance.**

- Bactericidal activity: all gram+ and gram- bacteria (including Pseudomonas aeruginosa, Staphylococcus aureus, Enterococcus hirae, Escherichia coli).
- Fungicidal activity: Aspergillus niger, Candida albicans
- Virucidal activity: poliovirus type 1, Adenovirus type 5

CODE	DESCRIPTION	PACK
408 004 467	USP surface disinfectant cleaner	Box with 12 x 750 ml bottles
408 004 471	USP surface disinfectant cleaner	1 x 750 ml bottle
408 004 515	USP surface disinfectant cleaner	10 L jerrycan

## DEGREASING DISINFECTANT CLEANER ACTIVATED CHLORINE



Degreasing disinfectant cleaner with deodorizing effect, particularly effective for disinfecting floors, walls, toilets, taps, steel, toilets and changing rooms. It is employed in hospitals, nursing homes, nursing homes, schools, nurseries and homes in general. It is a medical-grade product (USP) registered with the Ministry of Health, compliant with CAM and with EPD certified environmental performance. Suitable for use in ministerial anti-Ebola protocols. To be diluted.

CODE	DESCRIPTION	PACK
408 004 466	USP chlorine-active degreasing disinfectant cleaner	Box with 12 x 1 L bottles
408 004 472	USP chlorine-active degreasing disinfectant cleaner	1 x 1 L bottle
408 004 507	USP chlorine-active degreasing disinfectant cleaner	10 L jerrycan

## MICROFIBRE CLOTH



CODE	DESCRIPTION	PACK
402 004 478	30x40 cm microfiber cloth	Box with 20 pcs

### OIL BIO REMOVER



**OIL BIO REMOVER®**  
HYDROCARBON EMULSIFYING  
BIOLOGICAL ABSORBENT

#### Biologic hydrocarbon absorbent specific for soil

OIL BIO REMOVER is a biological hydrocarbon absorbent composed of biological surfactants obtained by a natural fermentation process, making it a biodegradable product with negligible environmental impact. The main benefit of the biological surfactants is that they produce a low surface tension for the water and hydrocarbons, for effective emulsification of the encrusted hydrocarbons. For removal of the most difficult hydrocarbons, dilute the product in water from 1:15 up to 1:1500.

#### STRONG POINTS

- 100% biodegradable
- Natural product
- Product manufactured from renewable resources
- Low environmental impact
- Excellent emulsifier
- Non-corrosive

#### APPLICATIONS

- It can be used for soil remediation
- Washing crude oil from tanks
- Degreasing of hard washable surfaces
- Washing of oil tankers
- Removal of oil stains

#### FEATURES

- Appearance: brown liquid
- Odour: none
- pH: 7 ± 0.5
- Storage temperature: +5° to +35°C

CODE	DESCRIPTION	PACKAGING
409 002 810	Hydrocarbon emulsifying biological absorbent OIL BIO REMOVER	5 L jerrycan
409 002 811		25 L jerrycan

#### BIOREMEDIATION

Bioremediation is a waste-management technique that involves the use of organisms to remove or neutralize hydrocarbon pollutants from a contaminated site. The innovation represented by bioremediation consists in the possibility to work directly on the site instead of removing the soil to decontaminate it elsewhere, avoiding further environmental damage caused by this removal.

#### HOW IT WORKS

Autochthonous bacteria, that is those found naturally in the soil, are not sufficient to decontaminate the ground in a short timeframe. As such, biological reinforcement is required to stimulate their reproduction, accelerating the decontamination process.

Once a sufficient quantity of micro-organisms specially selected for the site has been obtained in the laboratory, they are then inoculated into the soil, thus accelerating the hydrocarbon conversion process into carbon dioxide and water.

In order for this process to proceed correctly, certain chemical and physical site conditions must be respected, such as:

- Correct oxygen concentration (the greater the quantity of oxygen used, the quicker the cleaning process will be)
- Optimum temperature (must be maintained around 28°C)
- Humidity level (between 15% and 20%)
- pH (between 6.5 and 8.0).

In conclusion, bioremediation favours ground decontamination from hydrocarbons quickly and with the minimum possible impact on the environment.

AIRBANK offers a professional consulting service and cutting-edge products for reclaiming soils contaminated by pollutants, and hydrocarbons in particular.

ON REQUEST

Pictures indicated in this catalogue are representative and not binding for the supplier in terms of layout and colours. They may be subject to changes by the supplier without prior notice.

# SOLVLESS



### Degreaser without solvents

SOLVLESS degreaser to remove rubber marks, bitumen and wax residues, fat, oil, steel processing dust and paste, aluminium, non-ferrous metals, etc. This water-based degreaser features a pleasant scent and it is made of natural raw materials, such as coconuts. These ingredients give the product its excellent solvent power and are delicate on the surfaces treated.



### STRONG POINTS

- Exempted from labelling (in compliance with EU Directives)
- Use: spray, brush and immersion
- VOC-free

### APPLICATIONS

- Industry
- Workshops
- Machine tools
- Mechanical component washing

### FEATURES

- Exempted from labelling, in compliance with EU Directives
- VOC-free
- Pleasant odour
- Ready to use
- Low foam
- Water-based

WATCH THE VIDEO



CODE	DESCRIPTION	PACKAGING
409 003 549	SOLVLESS degreaser	20 L jerrycan



Pictures indicated in this catalogue are representative and not binding for the supplier in terms of layout and colours. They may be subject to changes by the supplier without prior notice.



### ODORLESS



#### Biological elimination of foul smells in waste containers and tips

Many organic materials generate foul odours in their natural oxidation and decay process.

The system normally used in these cases is to use perfumes or similar substances to cover up odours. ODORLESS, on the other hand, uses innocuous, non-pathogenic micro-organisms to provide a solution to foul smells.

#### STRONG POINTS

- Destruction of waste odours by a natural process
- Optimum distribution due to surfactant content
- Surfactants help to emulsify fats, facilitating degradation by the micro-organisms

#### APPLICATIONS

- Waste containers
- Composting containers
- Slaughterhouses
- Fisheries
- Butcher's shops
- Tips
- Waste management

#### FEATURES

- Selected and stabilized mixture of bacterial cultures, able to degrade organic substances
- The enzymes produced by the micro-organisms reduce odours via a natural process
- ODORLESS is composed of micro-organisms and therefore must NOT come into contact with bleach or acidic and/or basic products

CODE	DESCRIPTION	PACKAGING
409 002 339	ODORLESS odour neutralizing powder	5 L jerrycan
409 002 340		25 L jerrycan



Pictures indicated in this catalogue are representative and not binding for the supplier in terms of layout and colours. They may be subject to changes by the supplier without prior notice.



### APPLICATIONS

- Septic tanks
- Restaurants and bars
- Hotels
- Hospitals
- Canteens and food preparation areas
- Food sector, slaughterhouses and fishmongers

## GREASELESS



### Biological Liquid for waste water

Ideal for cleaning drainage pipes. The micro-organisms contained in GREASELESS have been selected for their capacity to destroy grease and prevent the formation of fats and other organic substances, favouring their dissolution. The product must be diluted with 1 to 10 parts warm water (not over 30°C) before use. Due to the biological nature of the product, avoid excessive temperature changes and do not put chemical substances down the drains immediately after use.

### STRONG POINTS

- 100% biodegradable
- Does not contain micro-organisms harmful to humans or animals
- Decrease of pipe clogging
- 60% lowering of draining operations for grease separators
- GMO-free
- Elimination of smells

CODE	DESCRIPTION	PACKAGING
409 000 356	GREASELESS biological liquid for waste water	5 L jerrycan
409 000 357		25 L jerrycan



### APPLICATIONS

- Restaurants and bars
- Hotels
- Hospitals
- Public places
- Food
- industry
- Floors
- Walls
- Tiles
- Shower
- Bathroom

## DIRTLESS



### Biological liquid for washing of waste containers and surfaces

DIRTLESS combines the benefits of surfactants and biotechnology to solve the problem of cleaning hard surfaces and deodorizing waste storage containers. The primary cleaning effect of the product is based on using a biodegradable mixture of surfactants which help the emulsification and mobility of organic substances. The microbial building blocks of DIRTLESS produce enzymes which help degrade organic stains (fat, protein, starch and cellulose). The product must be diluted to 10% with cold water before use. We recommend leaving it to act for at least 20 minutes before rinsing.

### STRONG POINTS

- 100% biodegradable
- Does not contain micro-organisms harmful to humans or animals
- Salmonella Free (tested by independent lab)
- GMO-free
- Sanitizes and deodorizes

CODE	DESCRIPTION	PACKAGING
409 000 359	DIRTLESS biological liquid for washing of waste containers and surfaces	5 L jerrycan
409 000 360		25 L jerrycan

Pictures indicated in this catalogue are representative and not binding for the supplier in terms of layout and colours. They may be subject to changes by the supplier without prior notice.

### NIFFLESS



#### Biological detergent and deodorizer

NIFFLESS is a concentrated biological product formulated with the specific aim of removing marks and stains which can form on the ceramic part of urinals and toilets, eliminating the odours which normally accompany them.

It contains a mixture of micro-organisms in a liquid formula which have been selected for their ability to grow and produce a large quantity of enzymes which contribute to eliminating the organic waste substances.

The product also contains a surfactant mixture able to reinforce the cleaning effect of the product and penetrate tough surface stains.

The combination of micro-organisms which produces enzymes and surfactants allows the formula to provide exceptional results. It can be used as a detergent on all washable surfaces as the elements favour dissolution of uric acid crystals without having to resort to abrasive acids. The product must be diluted to 10 - 20% with cold water before use. The product's ingredients are completely biodegradable and therefore do not interfere with the flow.



**NIFFLESS®**  
BIOLOGICAL DETERGENT AND DEODORIZER

#### STRONG POINTS

- 100% biodegradable *(tested by independent lab)*
- Does not contain micro-organisms harmful to humans or animals
- Salmonella Free
- Removes stains and spots
- Sanitizes and deodorizes
- Helps preserving the pipes

#### APPLICATIONS

- Restaurants and bars
- Hotels
- Hospitals
- Public places
- Food industry

#### FEATURES

- Appearance: white liquid
- Scent: pine
- Storage temperature: +5° to +30°C (away from heat sources)

CODE	DESCRIPTION	PACKAGING
409 000 362	NIFFLESS biological detergent and deodorizer	5 L jerrycan



Pictures indicated in this catalogue are representative and not binding for the supplier in terms of layout and colours. They may be subject to changes by the supplier without prior notice.

# WATERLESS



**WATERLESS®**  
BIODEGRADABLE LIQUID  
FOR WATERLESS CLEANING

### Ecological water-free cleaning

WATERLESS is a natural and 100% biodegradable liquid. It is easy to use, requiring only soft microfibre cloths. It allows all washable surfaces to be cleaned without water using just one pass and no rinsing. The liquid is sprayed onto the parts to be cleaned (bodywork, metal, plastic, rubber, glass) before wiping with a slightly moistened microfibre cloth.

Cleaning PV panels requires a simple specific tool: a pressure pump and telescopic shaft with a frame to hold a rectangular microfibre cloth. Use of this product allows cleaning even where there is no water supply, and without wetting either the surface requiring cleaning (e.g. solar panels) or the support surface (e.g. the roof). Thanks to this system and its low pH (2.45 compared to pH 4.00 of reverse-osmosis purified water, which must then be piped to the installation), the solution is ideal for cleaning solar panels, and can help improve their output.

Surfactant- and solvent-free liquid cleaning product; it allows removal of dirt from all washable materials (painted surfaces, plastics and laminates, plexiglass, glass, polished and satin steel, metals) without foaming and without rinsing. It can be used for cleaning surfaces in contact with foodstuffs.

### Water-less cleanser

Surface cleaning liquid, ideal to remove contaminated micro-organisms from the environment (it removes the bioburden from surfaces completely, and it can significantly reduce microbial recontamination up to 15 days from the cleaning action). Natural, with essential eucalyptus oil and plant-based surfactants, solvent-free. With a pleasant, balsamic and deodorant eucalyptus scent.

### STRONG POINTS

- Ecological
- Water savings
- All-in-one: a single product for all materials

### APPLICATIONS

- Cars
- Motorcycles
- Vans
- Trucks
- Campers
- Boats
- All washable surfaces

### FEATURES

- 100% Biodegradable
- Ecological
- No chemical components
- Surfactant free
- Non-foaming
- Composed of herbal distillates and natural acids

#### Water-less strong

Strong cleanser, gentle on surfaces, slightly foamy. 100% plant-based.

ON REQUEST

CODE	DESCRIPTION	PACKAGING
409 002 691	Multi-use cloth	20 cloths
409 002 693	WATERLESS refill,	5 L jerrycan (equivalent to 50 x 750 ml spray bottles)
409 002 694	WATERLESS kit	6 x 750 ml spray bottles
409 002 770	WATERLESS spray bottle and microfibre cloth	1 x 750 ml spray bottle + 2 microfibre cloths
409 002 857	WATERLESS display kit	6 x 750 ml spray bottles + 12 microfibre cloths
409 004 512	WATERLESS sanitizer bottle	1 x 500 ml bottle



WATCH THE VIDEO



Pictures indicated in this catalogue are representative and not binding for the supplier in terms of layout and colours. They may be subject to changes by the supplier without prior notice.







# CONTAINMENT PRODUCTS

10	SMALL AND MEDIUM STORAGE SOLUTIONS .....	page 122
11	LARGE STORAGE SOLUTIONS.....	page 165
12	LIQUIDS CONTAINMENT AND TRANSPORT .....	page 176
13	SOLIDS CONTAINMENT AND TRANSPORT .....	page 229

### CONTAINMENT SYSTEMS

Airbank offers two types of containment systems: steel and polyethylene (PE). The steel tanks are customisable, while the polyethylene (PE) ones offer high levels of compatibility with corrosive chemical substances.



**SPILL HAZARD**

Airbank has created a warning sign\* which will be supplied together with Airbank containment products; this sign, when correctly positioned, allows operatives to identify the areas of the work environment in which a spill hazard exists.

A second sign carrying the same hazard signal, is already positioned on the Airbank containment product.

The goal of the supplied sign, which should be positioned on a wall near to where the Airbank product will be installed (e.g. containment sump for drums or tanks), is to rapidly attract the attention of the workers to the hazard in the work area; it must therefore be installed in a location where it is highly visible, even from a distance.

CODE	DESCRIPTION
410 003 854	Spill hazard sticker 9 x h 15 cm
410 003 814	Spill hazard sign, A4

**WATCH THE VIDEO**



\*The symbols on the signs offered by Airbank do not fall within those specified by international standards (EN ISO 7010), and as such purchasers must be aware that they are not displaying a universally recognised symbol but rather a sign which, while it respects the general criteria, does not incorporate the preventive measures codified by the standard itself.

#### HOW TO CALCULATE THE CORRECT CAPACITY OF A SPILL SUMP

Italian law (Ref. D.M. 392 16/05/1996 for oils and D.M. 18/05/1995 for deposits of hydroalcoholic solutions, decision of 27/07/1984) states that containment sumps must contain the greatest of the following:



##### EXAMPLE 1

- TOTAL STORED LITRES 1500 thus  $1500 \times 1/3 = 500 \text{ L}$
- LARGEST STORED CONTAINER: **1000 L**

**1000 L > 500 L**

CONSEQUENTLY THE SUMP **MUST CONTAIN 1000 L** as this is the higher of the two.

##### EXAMPLE 2

- TOTAL STORED LITRES 5000 thus  $5000 \times 1/3 = 1667 \text{ L}$
- LARGEST STORED CONTAINER: **1000 L**

**1000 L < 1667 L**

CONSEQUENTLY THE SUMP **MUST CONTAIN 1667 L** as this is the higher of the two.

Pictures indicated in this catalogue are representative and not binding for the supplier in terms of layout and colours. They may be subject to changes by the supplier without prior notice.

## STEEL CONTAINMENT SUMPS



**Sump features:** carbon steel with reinforced frame, MIG welded. The watertightness of the sumps is checked via non-destructive (dye penetrant) testing.

**Hot-galvanised carbon steel** grille with heavy duty handles, arranged on the "L" welded perimeter profile and (for some models) central reinforcing element.

**Cabinets** all fitted with natural ventilation grille.

### SUMP FOR 1 X 200 LITRE DRUM



CODE	DESCRIPTION	SUMP CAPACITY
410 000 374	Sump for 1 x 200 litre drum • painted 860 x 860 x h 430 mm	240 L
410 000 375	Sump for 1 x 200 litre drum • galvanised 860 x 860 x h 430 mm	240 L

### SPILL SUMP WITH FRAME FOR 1 X 200 LITRE DRUM



CODE	DESCRIPTION	SUMP CAPACITY
410 000 376	Spill sump with frame for 1 x 200 litre drum • painted 860 x 860 x h 1460 mm	240 L
410 000 377	Spill sump with frame for 1 x 200 litre drum • galvanised 860 x 860 x h 1460 mm	240 L

### SPILL SUMP WITH FRAME FOR 1 X 200 LITRE DRUM, WITH SAFETY ROD



CODE	DESCRIPTION	SUMP CAPACITY
410 003 486	Spill sump with frame for 1 x 200 litre drum, with safety rod • Painted 860 x 860 x h 1460 mm	240 L



### SPILL SUMP WITH SHEET METAL WALLS FOR 1 X 200 L DRUM



CODE	DESCRIPTION	SUMP CAPACITY
410 004 865	Spill sump with 3 sheet metal walls for 1 x 200 L drum • painted 860 x 860 x h 1460 mm	240 L
410 004 866	Spill sump with 3 sheet metal walls for 1 x 200 L drum • galvanised 860 x 860 x h 1460 mm	240 L

### SPILL SUMP WITH MESH WALLS FOR 1 X 200 L DRUM



CODE	DESCRIPTION	SUMP CAPACITY
410 004 863	Spill sump with 3 mesh walls for 1 x 200 L drum • painted 860 x 860 x h 1460 mm	240 L
410 004 864	Spill sump with 3 mesh walls for 1 x 200 L drum • galvanized 860 x 860 x h 1460 mm	240 L

### CABINET FOR 1 X 200 LITRE DRUM



CODE	DESCRIPTION	SUMP CAPACITY
410 000 378	Cabinet for 1 x 200 litre drum • painted 860 x 860 x h 1600 mm	240 L
410 000 379	Cabinet for 1 x 200 litre drum • galvanised 860 x 860 x h 1600 mm	240 L

### MOBILE SUMP FOR 1 X 200 LITRE DRUM



CODE	DESCRIPTION	SUMP CAPACITY
410 000 380	Mobile sump for 1 x 200 litre drum • painted 860 x 860 x h 1000 mm	240 L
410 000 381	Mobile sump for 1 x 200 litre drum • galvanised 860 x 860 x h 1000 mm	240 L

## SUMP FOR 2 X 200 LITRE DRUMS



CODE	DESCRIPTION	SUMP CAPACITY
410 000 382	Sump for 2 x 200 litre drums • painted 1340 x 850 x h 330 mm	260 L
410 000 383	Sump for 2 x 200 litre drums • galvanised 1340 x 850 x h 330 mm	260 L

## SPILL SUMP WITH FRAME FOR 2 X 200 LITRE DRUMS



Opening on the long side.

CODE	DESCRIPTION	SUMP CAPACITY
410 000 384	Spill sump with frame for 2 x 200 litre drums • painted 1350 x 860 x h 1460 mm • Opening on the long side	260 L
410 000 385	Spill sump with frame for 2 x 200 litre drums • galvanised 1350 x 860 x h 1460 mm • Opening on the long side	260 L

Opening on the short side.

CODE	DESCRIPTION	SUMP CAPACITY
410 000 386	Spill sump with frame for 2 x 200 litre drums • painted 1350 x 860 x h 1460 mm • Opening on the short side	260 L
410 000 387	Spill sump with frame for 2 x 200 litre drums • galvanised 1350 x 860 x h 1460 mm • Opening on the short side	260 L

## SPILL SUMP WITH FRAME FOR 2 X 200 LITRE DRUMS, WITH SAFETY ROD



CODE	DESCRIPTION	SUMP CAPACITY
410 003 937	Spill sump with frame for 2 x 200 litre drums, with safety rod • Painted 1350 x 860 x h 1460 mm	260 L

### SPILL SUMP WITH SHEET METAL WALLS FOR 2 X 200 L DRUMS



CODE	DESCRIPTION	SUMP CAPACITY
410 004 869	Spill sump with 3 sheet metal walls for 2 x 200 L drums • painted 1350 x 860 x h 1460 mm	260 L
410 004 870	Spill sump with 3 sheet metal walls for 2 x 200 L drums • galvanised 1350 x 860 x h 1460 mm	260 L

### SPILL SUMP WITH MESH WALLS FOR 2 X 200 L DRUMS



CODE	DESCRIPTION	SUMP CAPACITY
410 004 867	Spill sump with 3 mesh walls for 2 x 200 L drums • painted 1350 x 860 x h 1460 mm	260 L
410 004 868	Spill sump with 3 mesh walls for 2 x 200 L drums • galvanized 1350 x 860 x h 1460 mm	260 L

### MESH CABINET WITH PROTECTION FOR 2 X 200 LITRE DRUMS



CODE	DESCRIPTION	SUMP CAPACITY
410 000 390	MESH cabinet for 2 x 200 L drums • painted 1380 x 910 x h 1520 mm	260 L
410 000 391	MESH cabinet for 2 x 200 L drums • galvanised 1380 x 910 x h 1520 mm	260 L

## CABINET FOR 2 X 200 LITRE DRUMS



CODE	DESCRIPTION	SUMP CAPACITY
410 000 388	Cabinet for 2 x 200 litre drums • painted 1350 x 860 x h 1570 mm	260 L
410 000 389	Cabinet for 2 x 200 litre drums • galvanised 1350 x 860 x h 1570 mm	260 L

## DRUM CABINET WITH SHELF FOR 2 X 200 LITRE DRUMS



CODE	DESCRIPTION	SUMP CAPACITY
410 000 392	Drum cabinet with shelf for 2 x 200 litre drums • painted 1350 x 860 x h 1900 mm	260 L
410 000 393	Drum cabinet with shelf for 2 x 200 litre drums • galvanised 1350 x 860 x h 1900 mm	260 L

## MOBILE SUMP FOR 2 X 200 LITRE DRUMS



CODE	DESCRIPTION	SUMP CAPACITY
410 000 394	Mobile sump for 2 x 200 litre drums • painted 860 x 1340 x h 1000 mm	260 L
410 000 395	Mobile sump for 2 x 200 litre drums • galvanised 860 x 1340 x h 1000 mm	260 L

## MOBILE SUMP FOR 2 X 200 LITRE DRUMS, WITH SAFETY STRAP



CODE	DESCRIPTION	SUMP CAPACITY
410 004 613	Mobile sump for 2 x 200 litre drums, with safety strap • painted 860 x 1560 x h 1000 mm	260 L
410 004 614	Mobile sump for 2 x 200 litre drums, with safety strap • galvanised 860 x 1560 x h 1000 mm	260 L



### SUMP FOR 4 X 200 LITRE DRUMS



CODE	DESCRIPTION	SUMP CAPACITY
410 000 396	Sump for 4 x 200 litre drums • painted 1340 x 1250 x h 300 mm	330 L
410 000 397	Sump for 4 x 200 litre drums • galvanised 1340 x 1250 x h 300 mm	330 L

### IN-LINE SPILL SUMP FOR 4 X 200 LITRE DRUMS



CODE	DESCRIPTION	SUMP CAPACITY
410 000 398	In-line sump for 4 x 200 litre drums • painted 2720 x 850 x h 330 mm	540 L
410 000 399	In-line sump for 4 x 200 litre drums • galvanised 2720 x 850 x h 330 mm	540 L

### SPILL SUMP WITH FRAME FOR 4 X 200 LITRE DRUMS



CODE	DESCRIPTION	SUMP CAPACITY
410 000 400	Spill sump with frame for 4 x 200 litre drums • painted 1350 x 1260 x h 1430 mm	330 L
410 000 401	Spill sump with frame for 4 x 200 litre drums • galvanised 1350 x 1260 x h 1430 mm	330 L

### SPILL SUMP WITH FRAME FOR 4 X 200 LITRE DRUMS, WITH SAFETY ROD



CODE	DESCRIPTION	SUMP CAPACITY
410 003 837	Spill sump with frame for 4 x 200 litre drums, with safety rod • painted 1350 x 1260 x h 1430 mm	330 L

## SPILL SUMP WITH SHEET METAL WALLS FOR 4 X 200 L DRUMS



CODE	DESCRIPTION	SUMP CAPACITY
410 004 850	Spill sump with 3 sheet metal walls for 4 x 200 L drums • painted 1350 x 1260 x h 1430 mm	330 L
410 004 851	Spill sump with 3 sheet metal walls for 4 x 200 L drums • galvanised 1350 x 1260 x h 1430 mm	330 L

## SPILL SUMP WITH MESH WALLS FOR 4 X 200 L DRUMS



CODE	DESCRIPTION	SUMP CAPACITY
410 004 848	Spill sump with 3 mesh walls for 4 x 200 L drums • painted 1350 x 1260 x h 1430 mm	330 L
410 004 849	Spill sump with 3 mesh walls for 4 x 200 L drums • galvanized 1350 x 1260 x h 1430 mm	330 L

## CABINET FOR 4 X 200 LITRE DRUMS



CODE	DESCRIPTION	SUMP CAPACITY
410 000 402	Cabinet for 4 x 200 litre drums • painted 1350 x 1260 x h 1540 mm	330 L
410 000 403	Cabinet for 4 x 200 litre drums • galvanised 1350 x 1260 x h 1540 mm	330 L

### SUMP FOR 8 X 200 LITRE DRUMS



CODE	DESCRIPTION	SUMP CAPACITY
410 000 404	Sump for 8 x 200 litre drums • painted 2720 x 1250 x h 300 mm	620 L
410 000 405	Sump for 8 x 200 litre drums • galvanised 2720 x 1250 x h 300 mm	620 L

### SPILL SUMP WITH FRAME FOR 8 X 200 LITRE DRUMS



CODE	DESCRIPTION	SUMP CAPACITY
410 000 406	Spill sump with frame for 8 x 200 litre drums • painted 2720 x 1250 x h 1430 mm	620 L
410 000 407	Spill sump with frame for 8 x 200 litre drums • galvanised 2720 x 1250 x h 1430 mm	620 L

### CABINET FOR 8 X 200 LITRE DRUMS



CODE	DESCRIPTION	SUMP CAPACITY
410 000 408	Cabinet for 8 x 200 litre drums • painted 2720 x 1650 x h 1900 mm	1122 L



### DRUM STANDS

The steel stands are used to position the drums horizontally and rotate them on the spill sumps; the structure guarantees perfect drum stability and easier pouring of the stored liquid. Made in painted or galvanised carbon steel; each stand is supplied with 2 anchoring brackets.



410 000 410



410 000 412



410 000 414

#### NON STACKABLE models

CODE	DESCRIPTION	DIMENSIONS
410 000 410	Drum stand for 1 x 200 litre drum • Painted Recommended with spill sumps 410 000 382/383	600 x 600 x h 380 mm
410 000 411	Drum stand for 1 x 200 litre drum • Galvanised Recommended with spill sumps 410 000 382/383	600 x 600 x h 380 mm
410 000 412	Drum stand for 2 x 200 litre drums • Painted Recommended with spill sumps 410 000 396/397	1180 x 600 x h 380 mm
410 000 413	Drum stand for 2 x 200 litre drums • Painted Recommended with spill sumps 410 000 396/397	1180 x 600 x h 380 mm
410 000 414	Drum stand for 3 x 60 litre drums • painted	1180 x 600 x h 380 mm
410 000 415	Drum stand for 3 x 60 litre drums • galvanised	1180 x 600 x h 380 mm



410 000 416



410 000 418



410 000 420

#### STACKABLE models

CODE	DESCRIPTION	DIMENSIONS
410 000 416	Nestable stand for 1 x 200 litre drum • painted	830 x 600 x h 810 mm
410 000 417	Nestable stand for 1 x 200 litre drum • galvanised	830 x 600 x h 810 mm
410 000 418	Nestable stand for 2 x 200 litre drums • painted	1330 x 600 x h 810 mm
410 000 419	Nestable stand for 2 x 200 litre drums • galvanised	1330 x 600 x h 810 mm
410 000 420	Nestable stand for 3 x 60 litre drums • painted	1330 x 600 x h 810 mm
410 000 421	Nestable stand for 3 x 60 litre drums • galvanised	1330 x 600 x h 810 mm



Pictures indicated in this catalogue are representative and not binding for the supplier in terms of layout and colours. They may be subject to changes by the supplier without prior notice.



### SUMP FOR 1 X 1000 LITRE IBC



CODE	DESCRIPTION	SUMP CAPACITY
410 000 422	Sump for 1 x 1000 litre IBC • painted 1340 x 1650 x h 620 mm	1150 L
410 000 423	Sump for 1 x 1000 litre IBC • galvanised 1340 x 1650 x h 620 mm	1150 L

### SPILL SUMP WITH RAISED PLATFORM FOR 1 X 1000 LITRE IBC



CODE	DESCRIPTION	SUMP CAPACITY
410 000 424	Spill sump with raised platform for 1 x 1000 litre IBC • painted 1340 x 1650 x h 1080 mm (of which 480 mm raised platform height)	1150 L
410 000 425	Spill sump with raised platform for 1 x 1000 litre IBC • galvanised 1340 x 1650 x h 1080 mm (of which 480 mm raised platform height)	1150 L

CODE	DESCRIPTION	SUMP CAPACITY
410 000 426*	Spill sump with raised platform for 1 x 1000 litre IBC • painted 1340 x 1650 x h 1780 mm (of which 480 mm raised platform height)	1150 L
410 000 427*	Spill sump with raised platform for 1 x 1000 litre IBC • galvanised 1340 x 1650 x h 1780 mm (of which 480 mm raised platform height)	1150 L

\*With galvanised protection.

### SUMP FOR 1 IBC WITH ROOF



CODE	DESCRIPTION	SUMP CAPACITY
410 003 695	Painted sump for 1 IBC with galvanised roof Maximum dimensions: 1900 x 1900 x h 2110 mm Sump dimensions: 1460 x 1650 x h 620 mm	1150 L
410 003 645	Galvanised sump for 1 IBC with galvanised roof Maximum dimensions: 1900 x 1900 x h 2110 mm Sump dimensions: 1460 x 1650 x h 620 mm	1150 L

### CABINET FOR 1 X 1000 LITRE IBC



CODE	DESCRIPTION	SUMP CAPACITY
410 000 428	Cabinet for 1 x 1000 litre IBC • painted 1350 x 1660 x h 1900 mm	1390 L
410 000 429	Cabinet for 1 x 1000 litre IBC • galvanised 1350 x 1660 x h 1900 mm	1390 L

Pictures indicated in this catalogue are representative and not binding for the supplier in terms of layout and colours. They may be subject to changes by the supplier without prior notice.

## CABINET WITH RAISED PLATFORM FOR 1 X 1000 LITRE IBC



CODE	DESCRIPTION	SUMP CAPACITY
410 000 430	Cabinet with raised platform for 1 x 1000 litre IBC • painted 1350 x 1660 x h 2600 mm (of which 480 mm raised platform height)	1390 L
410 000 431	Cabinet with raised platform for 1 x 1000 litre IBC • galvanised 1350 x 1660 x h 2600 mm (of which 480 mm raised platform height)	1390 L

## SUMP FOR 2 X 1000 LITRE IBCS



CODE	DESCRIPTION	SUMP CAPACITY
410 000 432	Sump for 2 x 1000 litre IBCs • painted 2720 x 1300 x h 420 mm	1131 L
410 000 433	Sump for 2 x 1000 litre IBCs • galvanised 2720 x 1300 x h 420 mm	1131 L

## SPILL SUMP WITH RAISED PLATFORM FOR 2 X 1000 LITRE IBCS



CODE	DESCRIPTION	SUMP CAPACITY
410 000 434	Spill sump with raised platform for 2 x 1000 litre IBCs • painted 2720 x 1650 x h 830 mm (of which 480 mm raised platform height)	1122 L
410 000 435	Spill sump with raised platform for 2 x 1000 litre IBCs • galvanised 2720 x 1650 x h 830 mm (of which 480 mm raised platform height)	1122 L
CODE	DESCRIPTION	SUMP CAPACITY
410 000 436*	Spill sump with raised platform for 2 x 1000 litre IBCs • painted 2720 x 1650 x h 1510 mm (of which 480 mm raised platform height)	1122 L
410 000 437*	Spill sump with raised platform for 2 x 1000 litre IBCs • galvanised 2720 x 1650 x h 1510 mm (of which 480 mm raised platform height)	1122 L

\*With galvanised protection.

## SUMP FOR 2 IBCS WITH ROOF



CODE	DESCRIPTION	SUMP CAPACITY
410 003 689	Painted sump for 2 IBC with galvanised roof Maximum dimensions: 3600 x 2000 x h 2110 mm Sump dimensions: 2840 x 1300 x h 420 mm	1131 L
410 003 694	Galvanised sump for 2 IBC with galvanised roof Maximum dimensions: 3600 x 2000 x h 2110 mm Sump dimensions: 2840 x 1300 x h 420 mm	1131 L

### CABINET FOR 2 X 1000 LITRE IBCs



CODE	DESCRIPTION	SUMP CAPACITY
410 000 408	Cabinet for 2 x 1000 litre IBCs • painted 2720 x 1650 x h 1900 mm	1122 L

### CABINET WITH RAISED PLATFORM FOR 2 X 1000 LITRE IBCs



CODE	DESCRIPTION	SUMP CAPACITY
410 000 438	Cabinet with raised platform for 2 x 1000 litre IBCs • painted 2720 x 1650 x h 2100 mm (of which 480 mm raised platform height)	1050 L

### SUMP FOR 3 X 1000 LITRE IBCs



CODE	DESCRIPTION	SUMP CAPACITY
410 000 440	Sump for 3 x 1000 litre IBCs • painted 3400 x 1340 x h 440 mm	1550 L
410 000 441	Sump for 3 x 1000 litre IBCs • galvanised 3400 x 1340 x h 440 mm	1550 L

### SPILL SUMP WITH 3 RAISED PLATFORMS FOR 3 X 1000 LITRE IBCs



CODE	DESCRIPTION	SUMP CAPACITY
410 000 442	Spill sump with 3 raised platforms for 3 x 1000 litre IBCs • painted 3400 x 1650 x h 830 mm (of which 480 mm raised platform height)	1550 L
410 000 443	Spill sump with 3 raised platforms for 3 x 1000 litre IBCs • galvanised 3400 x 1650 x h 830 mm (of which 480 mm raised platform height)	1550 L
CODE	DESCRIPTION	SUMP CAPACITY
410 000 444*	Spill sump with 3 raised platforms for 3 x 1000 litre IBCs • painted 3400 x 1650 x h 1510 mm (of which 480 mm raised platform height)	1550 L
410 000 445*	Spill sump with 3 raised platforms for 3 x 1000 litre IBCs • galvanised 3400 x 1650 x h 1510 mm (of which 480 mm raised platform height)	1550 L

\*With galvanized protection.

### SPILL SUMP WITH 2 RAISED PLATFORMS FOR 3 X 1000 LITRE IBCs



CODE	DESCRIPTION	SUMP CAPACITY
410 000 446	Spill sump with 2 raised platforms for 3 x 1000 litre IBCs • painted 3400 x 1650 x h 350 mm (+ 480 mm raised platform height)	1550 L
410 000 447	Spill sump with 2 raised platforms for 3 x 1000 litre IBCs • galvanised 3400 x 1650 x h 350 mm (+ 480 mm raised platform height)	1550 L

## DRUM OR IBC STORAGE RACKS WITH SPILL SUMP



Galvanized slot-in rack for storing IBCs or drums vertically and horizontally. Easy to assemble modular structure with high stability. With spill sump. Height-adjustable shelves to offer different solutions according different applications. Side frame and uprights are normally galvanized, while the sump is painted RAL 5012, or in PVC.

### RACK FOR HORIZONTAL STORAGE OF 4 X 200 LITRE DRUMS

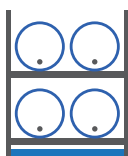

CODE	DESCRIPTION	DIMENSIONS OF RACK	SUMP DIMENSIONS	SUMP CAPACITY
410 000 448	Rack for horizontal storage of 4 drums	1400 x 800 x h 2100 mm	1340 x 1250 x h 350 mm	419 L

### RACK FOR HORIZONTAL STORAGE OF 6 X 200 LITRE DRUMS

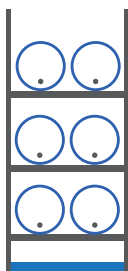

CODE	DESCRIPTION	DIMENSIONS OF RACK	SUMP DIMENSIONS	SUMP CAPACITY
410 000 449	Rack for horizontal storage of 6 drums	1400 x 800 x h 3300 mm	1340 x 1250 x h 350 mm	419 L

### RACK FOR 6 X 200 LITRE DRUMS (2 HORIZONTAL - 4 VERTICAL)

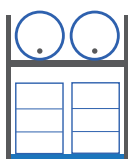

CODE	DESCRIPTION	DIMENSIONS OF RACK	SUMP DIMENSIONS	SUMP CAPACITY
410 000 450	Rack for 6 drums (2 horizontal - 4 vertical)	1400 x 800 x h 2325 mm	1340 x 1250 x h 350 mm	419 L

### RACK FOR 8 X 200 LITRE DRUMS (4 HORIZONTAL - 4 VERTICAL)

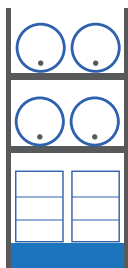

CODE	DESCRIPTION	DIMENSIONS OF RACK	SUMP DIMENSIONS	SUMP CAPACITY
410 000 451	Rack for 8 drums (4 horizontal - 4 vertical)	1400 x 800 x h 3300 mm	1340 x 1250 x h 500 mm	670 L





### RACK FOR HORIZONTAL STORAGE OF 8 X 200 LITRE DRUMS

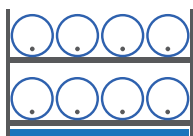

CODE	DESCRIPTION	DIMENSIONS OF RACK	SUMP DIMENSIONS	SUMP CAPACITY
410 000 452	Rack for horizontal storage of 8 drums	2700 x 800 x h 2100 mm	2650 x 1250 x h 350 mm	840 L

### RACK FOR 12 X 200 LITRE DRUMS (4 HORIZONTAL - 8 VERTICAL)

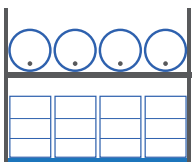

CODE	DESCRIPTION	DIMENSIONS OF RACK	SUMP DIMENSIONS	SUMP CAPACITY
410 000 453	Rack for 12 drums (4 horizontal - 8 vertical)	2700 x 800 x h 2325 mm	2650 x 1250 x h 350 mm	840 L

### RACK FOR HORIZONTAL STORAGE OF 12 X 200 LITRE DRUMS

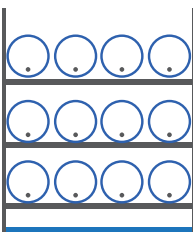

CODE	DESCRIPTION	DIMENSIONS OF RACK	SUMP DIMENSIONS	SUMP CAPACITY
410 000 454	Rack for horizontal storage of 12 drums	2700 x 800 x h 3300 mm	2650 x 1250 x h 350 mm	840 L

### RACK FOR 16 X 200 LITRE DRUMS (8 HORIZONTAL - 8 VERTICAL)

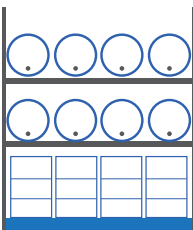

CODE	DESCRIPTION	DIMENSIONS OF RACK	SUMP DIMENSIONS	SUMP CAPACITY
410 000 455	Rack for 16 drums (8 horizontal - 8 vertical)	2700 x 800 x h 3300 mm	2650 x 1250 x h 500 mm	1345 L

### RACK FOR VERTICAL STORAGE OF 16 X 200 LITRE DRUMS



CODE	DESCRIPTION	DIMENSIONS OF RACK	SUMP DIMENSIONS	SUMP CAPACITY
410 000 456	Rack for vertical storage of 16 drums	2700 x 1000 x h 2700 mm	2650 x 1250 x h 500 mm	1345 L

### RACK FOR VERTICAL STORAGE OF 24 X 200 LITRE DRUMS

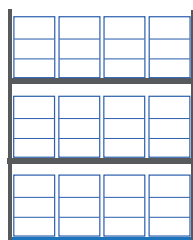

CODE	DESCRIPTION	DIMENSIONS OF RACK	SUMP DIMENSIONS	SUMP CAPACITY
410 000 457	Rack for vertical storage of 24 drums	2700 x 1000 x h 3900 mm	2650 x 1500 x h 500 mm	1614 L

## PVC SPILL SUMPS FOR RACKS



Portable PVC spill containment system offering high protection against large spills and leakages.

Containment product with innovative lightweight design, easy to assemble and ready to use.

Made from a single piece, easy and quick to assemble without the help of tools, lightweight and portable.

The indoor supports are reinforced with rigid PVC bars.

Resistant to fuels, acids, bases, salts and organic compounds in aqueous solutions.

Complies with the secondary containment regulations applicable to most industrial or military applications.

CODE	DESCRIPTION	SUMP CAPACITY
410 004 799	PVC spill sump for 2 IBC rack 1400 x 1600 x h 450 mm • inner feet	1000 L
410 004 800	PVC spill sump for 4 IBC rack 2700 x 1600 x h 305 mm • inner feet	1330 L
410 004 801	PVC spill sump for 6 IBC rack 3600 x 1600 x h 350 mm • inner feet	2002 L

## RACK FOR 2 X 1000 LITRE IBCS WITH PVC SPILL SUMP



CODE	DESCRIPTION	AVAILABLE DIMENSIONS OF RACK	SUMP DIMENSIONS	SUMP CAPACITY
410 004 802	Rack for 2 x IBCs with PVC spill sump	1400 x 1000 x h 2700 mm	1400 x 1600 x h 450 mm	1000 L

## RACK FOR 4 X 1000 LITRE IBCS WITH PVC SPILL SUMP



CODE	DESCRIPTION	AVAILABLE DIMENSIONS OF RACK	SUMP DIMENSIONS	SUMP CAPACITY
410 004 803	Rack for 4 IBCs with PVC spill sump	2700 x 1000 x h 2700 mm	2700 x 1600 x h 305 mm	1330 L

## RACK FOR 6 X 1000 LITRE IBCS WITH PVC SPILL SUMP



CODE	DESCRIPTION	AVAILABLE DIMENSIONS OF RACK	SUMP DIMENSIONS	SUMP CAPACITY
410 004 804	Rack for 6 x IBCs with PVC spill sump	3600 x 1000 x h 2700 mm	3600 x 1600 x h 350 mm	2002 L

### RACK FOR 8 X 1000 LITRE IBCS WITH PVC SPILL SUMP

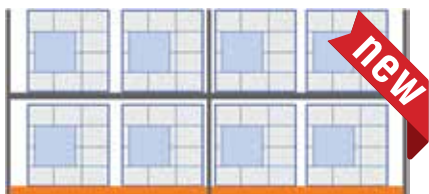

CODE	DESCRIPTION	AVAILABLE DIMENSIONS OF RACK	SUMP DIMENSIONS	SUMP CAPACITY
410 004 805	Racking for 8 IBCs with PVC spill sump	5400 x 1000 x h 2700 mm	2 spill sumps 2700 x 1600 x h 305 mm	2640 L

### RACK FOR 2 X 1000 LITRE IBCS WITH PAINTED STEEL SPILL SUMP

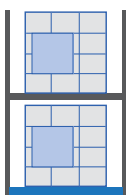

CODE	DESCRIPTION	AVAILABLE DIMENSIONS OF RACK	SUMP DIMENSIONS	SUMP CAPACITY
410 000 458	Rack for 2 x IBCs with painted steel spill sump	1400 x 1000 x h 2700 mm	1650 x 1340 x h 620 mm	1150 L

### RACK FOR 4 X 1000 LITRE IBCS WITH PAINTED STEEL SPILL SUMP

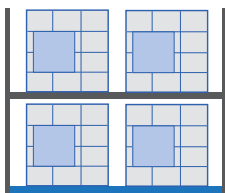

CODE	DESCRIPTION	AVAILABLE DIMENSIONS OF RACK	SUMP DIMENSIONS	SUMP CAPACITY
410 000 459	Rack for 4 x IBCs with painted steel spill sump	2700 x 1000 x h 2700 mm	2650 x 1250 x h 500 mm	1345 L

### RACK FOR 6 X 1000 LITRE IBCS WITH PAINTED STEEL SPILL SUMP

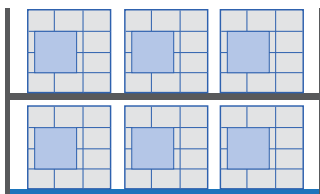

CODE	DESCRIPTION	AVAILABLE DIMENSIONS OF RACK	SUMP DIMENSIONS	SUMP CAPACITY
410 000 460	Rack for 6 x IBCs with painted steel spill sump	3600 x 1000 x h 2700 mm	3550 x 1250 x h 550 mm	2109 L

### RACK FOR 8 X 1000 LITRE IBCS WITH PAINTED STEEL SPILL SUMP

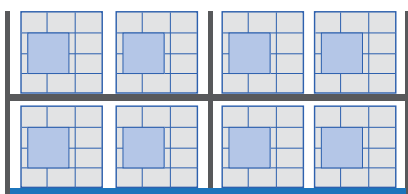

CODE	DESCRIPTION	AVAILABLE DIMENSIONS OF RACK	SUMP DIMENSIONS	SUMP CAPACITY
410 003 628	Racking for 8 IBCs with painted steel spill sump	5400 x 1000 x h 2700 mm	2 spill sumps 2650 x 1250 x h 500 mm	2690 L

## DRUM RACK WITH SUMP AND GRID SHELVES

Galvanized steel rack with spill sump and grid shelves. Suitable for storage of lab drums and jerrycans. Sturdy modular structure for easy assembling and height-adjustable shelves to offer different solutions according different applications. PE or painted steel spill sump.



CODE	DESCRIPTION	AVAILABLE DIMENSIONS OF RACK	SUMP DIMENSIONS	SUMP CAPACITY
410 000 281	Rack with painted spill sump and 3 x grid shelves	1400 x 1000 x h 2325 mm	1340 x 1250 x h 300 mm	330 L
410 000 282		2700 x 1000 x h 2700 mm	2650 x 1250 x h 500 mm	1345 L
410 004 859	Rack with PE spill sump and 3 x grid shelves	1400 x 1000 x h 2325 mm	1250 x 1250 x h 475 mm	450 L <b>new</b>
410 004 860	Rack with PE spill sump and 3 x grid shelves	2700 x 1000 x h 2700 mm	2495 x 1290 x h 475 mm	1050 L <b>new</b>



## LABORATORY DRUM RACK



High capacity galvanized rack for storage of small lab drums and jerrycans. Sturdy modular structure for easy assembling and height-adjustable shelves to offer different solutions according different applications.

CODE	DESCRIPTION	RACK DIMENSIONS
410 000 465	Laboratory drum rack	1000 x 320 x h 2000 mm
410 000 466		1000 x 520 x h 2000 mm
410 000 467		2000 x 320 x h 2000 mm
410 000 468		2000 x 520 x h 2000 mm

## RACKS ACCESSORIES



CODE	DESCRIPTION
410 000 461	Fixed drum stand (rack depth 800 mm.)
410 000 463	Rack corner guard





### SPILL SUMPS FOR FLAT SURFACES



Galvanised steel modular system for working or storage areas. The modular system can be equipped with joining elements and ramps to facilitate drum and IBC handling.

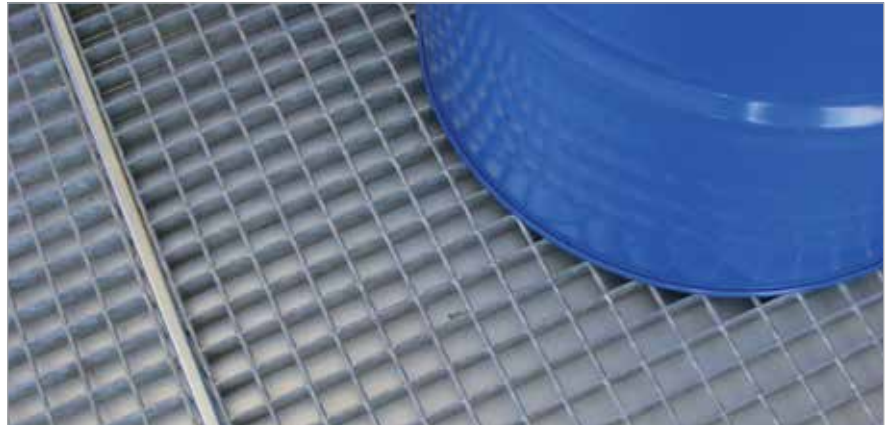

CODE	DESCRIPTION	SUMP CAPACITY
410 000 471	Spill sump for flat surfaces • 515 x 1015 x h 33 mm	16 L
410 000 472	Spill sump for flat surfaces • 1015 x 1015 x h 33 mm	33 L
410 000 473	Spill sump for flat surfaces • 1515 x 1015 x h 33 mm	50 L
410 000 474	Spill sump for flat surfaces • 1965 x 1015 x h 33 mm	65 L

CODE	DESCRIPTION	DIMENSIONS
410 000 475	Access ramp	1015 x 700 x h 33 mm
410 000 476		1515 x 700 x h 33 mm
410 000 477		1965 x 700 x h 33 mm
410 000 478	Corner ramp	700 x 700 x h 33 mm

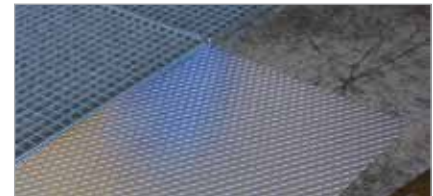

CODE	DESCRIPTION	SUMP CAPACITY
410 000 479	Spill sump for flat surfaces • 515 x 1015 x h 110 mm	58 L
410 000 480	Spill sump for flat surfaces • 1015 x 1015 x h 110 mm	114 L
410 000 481	Spill sump for flat surfaces • 1515 x 1015 x h 110 mm	170 L
410 000 482	Spill sump for flat surfaces • 1965 x 1015 x h 110 mm	200 L

CODE	DESCRIPTION	DIMENSIONS
410 000 483	Access ramp	1015 x 700 x h 110 mm
410 000 484		1515 x 700 x h 110 mm
410 000 485		1965 x 700 x h 110 mm
410 000 486	Corner ramp	700 x 700 x h 110 mm

CODE	DESCRIPTION	DIMENSIONS
410 000 487	Spill pallet joining element	500 x 15 mm
410 000 488		1000 x 15 mm
410 000 489		1500 x 15 mm
410 000 490		1950 x 15 mm

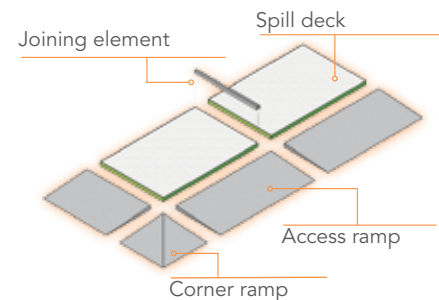

Pictures indicated in this catalogue are representative and not binding for the supplier in terms of layout and colours. They may be subject to changes by the supplier without prior notice.

## POLYETHYLENE SPILL SUMPS AND ACCESSORIES

Spill sumps, pallets and stands manufactured with rotomoulding in a single high density polyethylene (PE) piece. Ideal for safe storage of drums and IBCs. UV resistant and compatible with a large number of chemicals. They are stackable when empty and are supplied with removable polyethylene (PE) grid for easy cleaning. Safe, resistant, rot-proof and easy to handle, supplied in high visibility yellow or black.

ECO series tanks must be used in areas not exposed to direct sunlight and in environments with high temperatures.

### POLYETHYLENE (PE) SPILL PALLET FOR ONE 200 LITRE DRUM



CODE	DESCRIPTION	SUMP CAPACITY
410 000 491	Polyethylene (PE) spill sump for 1 x 200 litre drum 925 x 755 x h 555 mm	225 L

### POLYETHYLENE (PE) SPILL PALLET FOR TWO 200 LITRE DRUMS



CODE	DESCRIPTION	SUMP CAPACITY
410 000 492	Polyethylene (PE) spill sump for 2 x 200 litre drums 1270 x 705 x h 540 mm	270 L

### POLYETHYLENE (PE) SPILL SUMP FOR 2 X 200 LITRE DRUMS ON GRID OR DIRECTLY ON PALLET



CODE	DESCRIPTION	SUMP CAPACITY
410 000 493	Polyethylene (PE) spill sump on grid or directly on pallet for 2 x 200 litre drums • 1310 x 910 x h 380 mm	240 L

### ECO SERIES POLYETHYLENE (PE) SPILL PALLET FOR 2 X 200 LITRE DRUMS



CODE	DESCRIPTION	SUMP CAPACITY
410 000 494	ECO series polyethylene (PE) spill pallet for 2 x 200 litre drums 1265 x 700 x h 495 mm	220 L

### POLYETHYLENE (PE) SPILL SUMP WITH STEEL GRID FOR 2 X 200 LITRE DRUMS



CODE	DESCRIPTION	SUMP CAPACITY
410 000 500	Polyethylene (PE) spill sump (without grid) for 2 x 200 litre drums 1222 x 815 x h 350 mm	240 L
CODE	DESCRIPTION	
410 003 362	Steel grid for polyethylene (PE) sump code 410 000 500	

### POLYETHYLENE (PE) SPILL PALLET WITH RAMP FOR TWO 200 L DRUMS



CODE	DESCRIPTION	SUMP CAPACITY
410 000 503	Polyethylene (PE) spill pallet for two 200 l drums 660 x 1320 x h 430 mm	260 L
CODE	DESCRIPTION	CAPACITY
410 000 505	Spill sump load ramp 760 x 1800 x h 550 mm	295 kg

## POLYETHYLENE (PE) SPILL PALLET FOR FOUR 200 LITRE DRUMS



CODE	DESCRIPTION	SUMP CAPACITY
410 000 495	Polyethylene (PE) spill sump for 4 x 200 litre drums 1250 x 1250 x h 475 mm	450 L
410 000 496	Polyethylene (PE) spill sump for 4 x 200 litre drums 1290 x 1290 x h 705 mm	880 L

## POLYETHYLENE (PE) SPILL SUMP FOR 4 X 200 LITRE DRUMS IN LINE



CODE	DESCRIPTION	SUMP CAPACITY
410 000 497	Polyethylene (PE) spill sump for 4 x 200 litre drums in line 2410 x 693 x h 330 mm	450 L

## ECO SERIES POLYETHYLENE (PE) SPILL PALLET FOR 4 X 200 LITRE DRUMS



CODE	DESCRIPTION	SUMP CAPACITY
410 000 498	ECO series polyethylene (PE) spill pallet for 4 x 200 litre drums 1250 x 1250 x h 580 mm	450 L

## POLYETHYLENE (PE) SPILL SUMP WITH STEEL GRID FOR 4 X 200 LITRE DRUMS



CODE	DESCRIPTION	SUMP CAPACITY
410 000 502	Polyethylene (PE) spill sump (without grid) for 4 x 200 litre drums 1222 x 1222 x h 245 mm	240 L
CODE	DESCRIPTION	
410 003 363	Steel grid for polyethylene (PE) sump code 410 000 502	



### POLYETHYLENE (PE) SPILL PALLET WITH RAMP FOR FOUR 200 LITRE DRUMS



CODE	DESCRIPTION	SUMP CAPACITY
410 000 504	Polyethylene (PE) spill pallet for four 200 l drums 1320 x 1320 x h 430 mm	510 L
CODE	DESCRIPTION	CAPACITY
410 000 505	Spill sump load ramp 760 x 1800 x h 550 mm	295 kg

### MAXI RETENTION POLYETHYLENE (PE) SPILL PALLET



410 000 506

CODE	DESCRIPTION	SUMP CAPACITY
410 000 506	Maxi retention polyethylene (PE) spill pallet 1450 x 1740 x h 600 mm	1000 L
410 000 508	Maxi retention polyethylene (PE) spill pallet 1300 x 1300 x h 900 mm	1200 L
410 000 510	Maxi retention polyethylene (PE) spill pallet 1830 x 1830 x h 640 mm	1500 L



410 000 508



410 000 507

CODE	DESCRIPTION	DIMENSIONS
410 000 507	Receptacle to collect leakages (50 L)	630 x 575 x h 475 mm ø int. 500 mm
410 000 512*	Polyethylene (PE) reinforcement. Support for load capacity of 3600 kg	h 580 mm

\*accessory compatible with code 410 000 510



410 000 512\*



410 000 510

## RAISED PLATFORM FOR MAXI RETENTION POLYETHYLENE (PE) SPILL PALLETS



CODE	DESCRIPTION	HEIGHT FRONT	HEIGHT REAR
410 000 513	Raised platform for MAXI RETENTION polyethylene (PE) spill pallets • 1200 x 1200 mm	370 mm	405 mm

## ECO SERIES POLYETHYLENE (PE) SPILL PALLET FOR 1 X 1000 LITRE IBC



CODE	DESCRIPTION	SUMP CAPACITY
410 000 514	ECO series polyethylene (PE) spill pallet for 1 x 1000 litre IBC 1250 x 1250 x h 1130 mm	1050 L

## POLYETHYLENE (PE) SPILL SUMP FOR 2 X 1000 LITRE IBCS



CODE	DESCRIPTION	SUMP CAPACITY
410 000 515	Polyethylene (PE) spill sump for 2 x 1000 litre IBCs 2495 x 1290 x h 475 mm	1050 L

## ECO SERIES POLYETHYLENE (PE) SPILL PALLET FOR 2 X 1000 LITRE IBCS



CODE	DESCRIPTION	SUMP CAPACITY
410 000 516	ECO series polyethylene (PE) spill pallet for 2 x 1000 litre IBCs 2500 x 1300 x h 530 mm	1050 L

### POLYETHYLENE (PE) SPILL SUMP FOR 3 X 1000 LITRE IBCS



CODE	DESCRIPTION	SUMP CAPACITY
410 004 912	Polyethylene (PE) spill sump for 3 x 1000 litre IBCs 3280 x 1300 x h 575 mm	1650 L

### DRUM AND IBC COVERS



The PVC cover allows the external storage of IBCs and drums on the spill sump, preventing the latter to be filled in case of rain.

CODE	DESCRIPTION	
410 004 806	Cover for 1-drum PE spill sump 950 x 800 x h 1120 mm • for spill sump 410 000 491	<b>new</b>
410 004 807	Cover for 2-drum PE spill sump 1300 x 750 x h 1150 mm • for spill sump 410 000 492	<b>new</b>
410 004 808	Cover for 4-drum PE spill sump 1350 x 1350 x h 1160 mm • for spill sump 410 000 495	<b>new</b>
410 003 271	Cover for 1-IBC PE spill sump 1350 x 1350 x h 1250 mm • for spill sump 410 000 508	
410 003 273	Cover for 2-IBC PE spill sump 2550 x 1350 x h 1250 mm • for spill sump 410 000 515	
410 004 809	Cover for 1-drum steel spill sump 900 x 900 x h 1100 mm • for spill sump 410 000 374	<b>new</b>
410 004 810	Cover for 2-drum steel spill sump 1400 x 900 x h 1050 mm • for spill sump 410 000 382	<b>new</b>
410 004 811	Cover for 4-drum steel spill sump 1400 x 1300 x h 1030 mm • for spill sump 410 000 396	<b>new</b>
410 003 272	Cover for 1-IBC steel spill sump 1700 x 1390 x h 1250 mm • for spill sump 410 000 422	
410 003 274	Cover for 2-IBC steel spill sump 2750 x 1350 x h 1250 mm • for spill sump 410 000 432	

### POLYETHYLENE (PE) DRUM STANDS



CODE	DESCRIPTION
410 000 523	Polyethylene (PE) stand for 60 litre drums • 510 x 390 x h 390 mm
410 000 524	Polyethylene (PE) stand for 200 litre drums • 790 x 580 x h 580 mm
410 000 521	Nestable polyethylene (PE) stand for 60 litre drums • 865 x 390 x h 320 mm
410 000 522	Nestable polyethylene (PE) stand for 200 litre drums • 1230 x 580 x h 380 mm

## POLYETHYLENE TILTING DRUM TRUCK FOR 1 X 200 LITRE DRUM



Polyethylene tilting drum truck, compatible with standard 200 L drums. The drum truck is equipped with: ratchet strap for fixing the drum, 2 rubber wheels for easy movement and brake.

CODE	DESCRIPTION	SUMP CAPACITY
410 000 285	Polyethylene (PE) tilting drum truck for 1 x 200 litre drum 815 x 1740 x h 680 mm	250 L

## MOBILE POLYETHYLENE (PE) SPILL SUMP FOR 1 X 200 LITRE DRUM



CODE	DESCRIPTION	SUMP CAPACITY
410 000 525	Mobile polyethylene (PE) spill sump for 1 x 200 litre drum Ø 860 x 230 mm	40 L

## MOBILE POLYETHYLENE (PE) SUMP FOR DRUMS OR JERRYCANS



CODE	DESCRIPTION	SUMP CAPACITY
410 000 526	Mobile polyethylene (PE) sump for drums or jerrycans 1222 x 815 x h 350 mm	240 L

## MODULAR POLYETHYLENE (PE) SPILL DECKS



Ideal solution for containing spills and washing waters. Used to create large working racks. Reduced height for easier drum handling.

CODE	DESCRIPTION	SUMP CAPACITY	CAPACITY
410 000 527	Modular polyethylene (PE) spill deck 1240 x 645 x h 115 mm	60 L	600 Kg
410 000 528	Modular polyethylene (PE) spill deck 1240 x 1240 x h 115 mm	120 L	1000 Kg

CODE	DESCRIPTION	DIMENSIONS
410 000 529	Load ramp for platforms	775 x 580 x h 115 mm

CODE	DESCRIPTION	DIMENSIONS
410 000 530	Stainless steel joint for platforms	1195 x 40 x h 35 mm

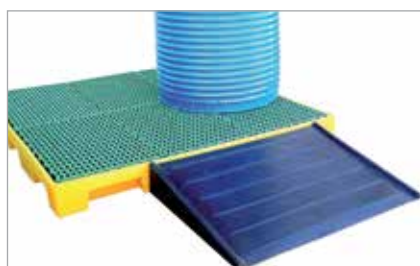



### SLOT-IN POLYETHYLENE (PE) SPILL DECK



Polyethylene (PE) spill deck. Drip-proof slot-in fittings on short and long side for quick modular assembly. Strong, ergonomic design and high capacity grid.

CODE	DESCRIPTION	SUMP CAPACITY	CAPACITY
410 000 531	Slot-in polyethylene (PE) spill deck 660 x 1320 x h 150 mm	80 L	500 Kg

### RACK WITH POLYETHYLENE (PE) DRIP TRAYS



Lab rack with iron frame and polyethylene (PE) spill pallets with grids. Ideal for storing small containers.

CODE	DESCRIPTION	SUMP CAPACITY
410 000 532	Rack with drip trays • 1010 x 670 x h 2000 mm	400 L

### POLYETHYLENE (PE) DRIP TRAYS



410 002 820

Polyethylene (PE) drip trays suitable for storage or small and medium-sized containers.

CODE	DESCRIPTION	SUMP CAPACITY
410 002 820	Polyethylene (PE) drip tray • 810 x 640 x h 230 mm	70 L
410 002 822	Polyethylene (PE) drip tray with feet • 810 x 640 x h 340 mm	70 L
410 000 533	Polyethylene (PE) drip tray • 990 x 645 x h 145 mm	100 L
410 000 535	Polyethylene (PE) drip tray • 990 x 645 x h 345 mm	200 L



410 002 822

CODE	DESCRIPTION
410 003 357	Grid for drip tray • 990 x 645 mm
410 003 358	Grid for drip tray • 810 x 640 mm



410 000 533



410 000 535

## POLYETHYLENE (PE) LAB DRIP TRAYS WITH GRID



CODE	DESCRIPTION	VOL. CAPACITY
410 004 325	Polyethylene (PE) lab drip tray with grid • 445 x 415 x h 45 mm	5 L
410 004 326	Polyethylene (PE) lab drip tray with grid • 635 x 410 x h 50 mm	8 L
410 004 327	Polyethylene (PE) lab drip tray with grid • 445 x 415 x h 90 mm	10 L
410 004 328	Polyethylene (PE) lab drip tray with grid • 640 x 410 x h 115 mm	20 L
410 004 329	Polyethylene (PE) lab drip tray with grid • 640 x 410 x h 165 mm	30 L
410 004 330	Polyethylene (PE) lab drip tray with grid • 640 x 410 x h 220 mm	40 L
410 004 331	Polyethylene (PE) lab drip tray with grid • 805 x 640 x h 150 mm	60 L
410 004 332	Polyethylene (PE) lab drip tray with grid • 1200 x 640 x h 160 mm	90 L

## PORTABLE CONTAINMENT SYSTEMS



Portable PVC spill containment system offering high protection against large spills and leakages. Innovative containment product with lightweight design, easy to assemble and ready to use. The large size makes it suitable to contain trucks, tankers and forklifts.



Made from a single piece, easy and quick to assemble without the help of tools, lightweight and portable.

The outer side supports are reinforced with rigid PVC bars. Resistant to fuels, acids, bases, salts and organic compounds in aqueous solutions.

Complies with the secondary containment regulations applicable to most industrial or military applications.



CODE	DESCRIPTION	SUMP CAPACITY
410 003 296	Portable containment system • 1200 x 1200 x h 200 mm	290 L
410 003 297	Portable containment system • 1200 x 1800 x h 200 mm	430 L
410 004 881	Portable containment system • 1800 x 1500 x h 305 mm	823 L <b>new</b>
410 003 298	Portable containment system • 2000 x 2000 x h 305 mm	1,200 L
410 000 549	Portable containment system • 3000 x 3000 x h 305 mm	2,700 L
410 000 550	Portable containment system • 3000 x 7900 x h 305 mm	7,200 L
410 000 551	Portable containment system • 3600 x 10900 x h 305 mm	12,000 L
410 000 552	Portable containment system • 3600 x 15200 x h 305 mm	16,500 L
410 000 553	Portable containment system • 4200 x 16400 x h 305 mm	21,000 L
410 000 554	Portable containment system • 4200 x 20100 x h 305 mm	29,400 L

PU CONTAINMENT SUMPS AND MODELS WITH FEET  
CAN ALSO BE SUPPLIED ON REQUEST

ON REQUEST

WATCH  
THE VIDEO



## ECOPALLETS

100% recyclable, reusable pallets, resistant to water and humidity, lightweight, with non-slip surface, easy to wash, can be handled on containers and conveyor belts; made from synthetic resin, unlike conventional wooden pallets they don't require "fumigation" and are fully resistant to chemicals (acids and solvents).

Forkable on four sides, stackable, the version with struts is ideal for use with transpallets and forklift trucks with rotating forks. With constant tare, therefore ideal for use in computerised packaging plants, food-grade version also available.

CODE	DESCRIPTION	CAPACITY
<b>410 002 764</b>	Pallet for light loads • 800 x 1200 x h 135 mm	Static: 1500 Kg Dynamic: 600 Kg
<b>410 003 705</b>	Pallet for medium loads • 1000 x 1200 x h 140 mm	Static: 1500 Kg Dynamic: 600 Kg



410 002 764



410 003 705

CODE	DESCRIPTION	CAPACITY
<b>410 003 706</b>	Pallet for heavy loads with runners • 800 x 1200 x h 150 mm	Static: 4000 Kg Dynamic: 1000 Kg On rack: 800 Kg
<b>410 003 707</b>	Pallet for heavy loads with runners • 1000 x 1200 x h 160 mm	Static: 4500 Kg Dynamic: 1500 Kg On rack: 800 Kg



410 003 706



410 003 707

## CABINETS

AIRBANK cabinets effectively solve all problems related to the need to store small and large amounts of items. The wide range of cabinets, including steel and polyethylene (PE) models, is able to meet all customer requirements by supplying the widest range of types and accessories.

### POLYETHYLENE (PE) CABINETS WITH STAINLESS STEEL SHELVING



Cabinet for outside or inside storage. Key locking, interior stainless steel shelving and sump. Perfect solution for storing corrosive materials.

CODE	DESCRIPTION	SHELVES
410 000 556	Polyethylene (PE) cabinet with stainless-steel shelves • 990 x 500 x h 1660 mm	3
410 000 557	Polyethylene (PE) cabinet with stainless-steel shelves • 975 x 520 x h 1180 mm	2

CODE	DESCRIPTION
410 000 780	Polyethylene (PE) drip tray for shelves (22 L)
410 000 781	Polyethylene (PE) drip tray for shelves (43 L)
410 000 558	Polyethylene (PE) spill pallet for cabinet, code 410 000 556
410 000 559	Polyethylene (PE) feet for cabinet, code 410 000 557

### GALVANIZED STEEL CABINET WITH SHELVES



Galvanized steel cabinet with shelves for safe storage of potentially hazardous and polluting substances, which can be moved via forklift.

Made with a solid hot-galvanised structure, they are also weather resistant and therefore ideal for outdoor use. They have a certified 209 litre spill sump with removable grid, to protect against accidental spills. They feature a double-wing door with lock and feature a dual separated internal compartment. The galvanised steel shelves are adjustable and removable, positioned on a rack to adapt to requirements; the side walls have air vents for storage of inflammable substances.

CODE	DESCRIPTION	SHELVES
410 003 324	Galvanised cabinet with 1 compartment with shelves and 1 compartment for storing 1 x 200 litre drum • 1395 x 905 x h 1600 mm	2
410 003 325	Galvanized cabinet with 2 separate shelved compartments 1395 x 905 x 1600 mm h	3
410 003 326	Galvanized cabinet with 2 separate shelved compartments 1395 x 905 x 1600 mm h	4

### PAINTED STEEL CABINET WITH SHELVES AND WHEELS



RAL 7035 painted steel cabinet with shelves equipped with four wheels (2 of which swivel with brake), handle for easy manoeuvring, hidden closing door, ventilation openings on the side walls.

CODE	DESCRIPTION	CAPACITY
410 004 880	Painted steel cabinet with shelves and wheels composed of: 1 shelf, 1 removable sump, 33 L spill sump • 124 x 61 x h 136 cm	50 kg per level



### POLYETHYLENE (PE) STORAGE CABINET WITH SUMP FOR 2 X 200 LITRE DRUMS



2-drum polyethylene (PE) spill cabinet.  
Spill sump with 280 L capacity. Double leaf door with stainless-steel hinges and key locking.

CODE	DESCRIPTION	SUMP CAPACITY
410 003 708	Polyethylene (PE) storage cabinet with sump for 2 x 200 litre drums 1500 x 1040 x h 1900 mm	280 L

### POLYETHYLENE (PE) STORAGE CABINETS WITH SUMP FOR 1000 L IBC OR 4 X 200 LITRE DRUMS



Cabinet with internal spill sump. Double wing door with stainless steel hinges and key locking. Perfect solution for storing corrosive materials. Suitable for one 1000 l IBC or 4 x 200 litre drums.

CODE	DESCRIPTION	SUMP CAPACITY
410 002 325	Polyethylene (PE) storage cabinet with sump for 1 x 1000 litre IBC or 4 x 200 litre drums • 1500 x 1500 x h 2150 mm	1000 L



### POLYETHYLENE CABINET WITH SUMP FOR 2 AND 4 DRUMS WITH SOFT-SEAL DOOR



High density polyethylene (HDPE) cabinet with spill sump, resistant to UV rays and the most aggressive chemical agents. Suitable for outdoor storage. The soft-seal doors on the front and the back provide excellent protection against atmospheric agents and dust. Lockable (not provided). Forklift-compatible.

CODE	DESCRIPTION	SUMP CAPACITY
410 004 602	2-drum PE cabinet w/soft-seal door 1565 x 995 x h 2110 mm	250 L
410 003 731	4-drum PE cabinet w/soft-seal door 1565 x 1620 x h 2110 mm	485 L



CODE	DESCRIPTION	PACK
410 002 328*	PE cabinet ramp	3
410 003 730*	PE cabinet ramp base	3

\* standard ramp composition to be combined with 2- and 4-drum cabinet (code 410002328+410003730)

\*\* product to be assembled

## SAFETY CABINETS FOR CHEMICAL PRODUCTS



410 004 019



410 004 020

Single piece steel sheet cabinets, thickness 7-8/10 mm, suitable for storing acidic and corrosive chemical substances, manufactured in compliance with current workplace health and safety and environmental legislation.

Reinforced hinged doors and lock with rods and handle, 4 adjustable shelves perforated to allow dripping, containment sump on base with 40 litre capacity, ventilation slots with fire-rated grids on sides and top, warning label per Italian Legislative Decree 81/08, provision for protective earth connection. RAL 7038 grey epoxy powder coating.

CODE	DESCRIPTION	SHELVES
410 004 019	Safety cabinet for chemical products, 2-door • 1000 x 500 x h 1000 mm	2
410 004 020	Safety cabinet for chemical products, 2-door • 1000 x 500 x h 2000 mm	4

CODE	DESCRIPTION	CAPACITY
410 000 569	Shelf for safety cabinet • 995 x 475 x h 30 mm	100 Kg

## SAFETY CABINETS FOR HAZARDOUS LIQUIDS



410 000 562

410 000 560



410 000 563

410 000 561

Single piece steel sheet cabinets, thickness 7-8/10 mm, suitable for storing hazardous substances, manufactured in compliance with current workplace health and safety and environmental legislation. Reinforced hinged door and lock with rods and handle, adjustable shelves perforated to allow dripping, containment sump on base with 19 or 40 litre capacity, ventilation slots with fire-rated grids on sides and top, warning label per Italian Legislative Decree 81/08, provision for protective earth connection. Epoxy powder coating.

CODE	DESCRIPTION	SHELVES
410 000 560	Safety cabinet for hazardous liquids, 2-door • 1000 x 500 x h 2000 mm	4
410 000 561	Safety cabinet for hazardous liquids, 2-door • 1000 x 500 x h 1000 mm	2
410 000 562	Safety cabinet for hazardous liquids, 1-door • 530 x 500 x h 2000 mm	4
410 000 563	Safety cabinet for hazardous liquids, 1-door • 530 x 500 x h 1000 mm	2

CODE	DESCRIPTION	CAPACITY
410 000 569	Shelf for safety cabinet • 995 x 475 x h 30 mm	100 Kg
410 000 570	Shelf for safety cabinet • 525 x 475 x h 30 mm	50 Kg

### CABINETS FOR PESTICIDES



410 000 566

410 000 564



410 000 567

410 000 565

Single piece steel sheet cabinets, thickness 7-8/10 mm, suitable for storing pesticides and other pollutants, manufactured in compliance with current workplace health and safety and environmental legislation and Italian Presidential Decree 290/01. Reinforced hinged doors and lock with rods and handle, adjustable shelves perforated to allow dripping, containment sump on base with 19 or 40 litre capacity, ventilation slots with fire-rated grids on sides and top, warning label per Italian Legislative Decree 81/08, provision for protective earth connection. Epoxy powder coating.

CODE	DESCRIPTION	SHELVES
410 000 564	Safety cabinet for pesticides, 2-door • 1000 x 500 x h 2000 mm	4
410 000 565	Safety cabinet for pesticides, 2-door • 1000 x 500 x h 1000 mm	2
410 000 566	Safety cabinet for pesticides, 1-door • 530 x 500 x h 2000 mm	4
410 000 567	Safety cabinet for pesticides, 1-door • 530 x 500 x h 1000 mm	2

CODE	DESCRIPTION	CAPACITY
410 000 569	Shelf for safety cabinet • 995 x 475 x h 30 mm	100 Kg
410 000 570	Shelf for safety cabinet • 525 x 475 x h 30 mm	50 Kg

### CABINETS FOR PPE AND FIREFIGHTING EQUIPMENT



410 002 812

410 002 813

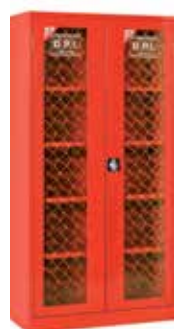

410 002 814



410 002 815

#### Cabinet with adhesive labelling as per Legislative Decree 81/08

Cabinets built in compliance with the current work safety and hygiene laws, indispensable for storing emergency equipment including fire extinguishers, overalls, helmets, masks, etc.

- RAL 3000 red.
- Reinforced shatter-proof glass or solid hinged steel door with opening greater than 180°.
- Lock with rods and handle. Top quality cold press-formed steel body, thickness 7-8/10 mm, in a single piece.
- Painted adjustable (50 mm slots) inner shelves with 2 hooks.
- Corrosion-resistant epoxy powder coating, applied at 180°C.
- Paint thickness 60 µm.

CODE	DESCRIPTION	SHELVES
410 002 812	Cabinet for PPE and firefighting equipment with 1 x shatter-proof glass door and 4 hooks 370 x 275 x h 545 mm	-
410 002 813	Cabinet for PPE and firefighting equipment with 1 x solid door 530 x 500 x h 2000 mm	4
410 002 814	Cabinet for PPE and firefighting equipment with 2 x shatter-proof glass doors 1000 x 500 x h 2000 mm	4
410 002 815	Cabinet for PPE and firefighting equipment with 2 x shatter-proof glass doors, 1 partition, 1 rod and 2 hooks 1000 x 500 x h 2000 mm	1+2
410 002 816	Cabinet for PPE and firefighting equipment with 2 x solid doors 1000 x 500 x h 2000 mm	4

CODE	DESCRIPTION	CAPACITY
410 002 817	Shelf for PPE cabinet • 525 x 475 x h 30 mm	50 Kg
410 002 818	Shelf for PPE cabinet • 995 x 475 x h 30 mm	100 Kg

## SAFETY CABINETS CERTIFIED FOR ACIDS, CHEMICALS AND BASES WITH EXHAUSTER



MANUFACTURED TO EN 61010-1, EN 16121:2013/A1:2017, EN 16122:2012 STANDARDS - CE MARKING - TÜV CERTIFIED

Completely produced in pickled and electrogalvanized steel, acid-proof epoxy powder coating applied in a heat tunnel at 200°C to a thickness of between 60 and 250 µm, as per certification report. Three drip trays made of painted acid-proof 10/10 mm thickness steel installed on adjustable and removable brackets.

Drip tray shelves to contain any liquids in the event of accidental container breakage.

Bottom sump in acid-resistant painted steel, thickness 10/10 mm. Activated charcoal filter. With CUNCTATOR® electronic device for charcoal filter replacement.



### FEATURES

- Single-piece, corrosion-resistant structure.
- Certified palletised base makes moving the cabinet easier.
- 110° door opening allowing shelf extraction without tilting it.
- Anti-spark corrosion-resistant hidden hinges.
- Safety lock with key and removable cylinder.
- EN 60335-1, EN 60335-2-80 and EN 50366 compliant IMQ IPX4 electric fan exhaust.
- Power supply: 220/230 volts.
- Electrical absorption: 65W.
- Hazard warning signs.
- Earthing system to prevent eventual discharges.
- Adjustable feet.
- CL insurance for the whole cabinet life



CODE	DESCRIPTION	OUTSIDE DIMENSIONS	INSIDE DIMENSIONS	SHELVES
410 000 571	Safety cabinet for acids, chemicals and alkalis with electric fan exhaust	600 x 500 x h 1998 mm	530 x 450 x h 1500 mm	3
410 000 572	Safety cabinet for acids, chemicals and alkalis with electric fan exhaust	1200 x 500 x h 1998 mm	1120 x 450 x h 1500 mm	3
410 000 577	Safety cabinet for acids, chemicals and alkalis with 2-leaf glass door	1200 x 500 x h 1998 mm	1120 x 450 x h 1500 mm	3
410 002 698	Safety cabinet for acids, chemicals and alkalis with 1 glass door	600 x 500 x h 1998 mm	530 x 450 x h 1500 mm	3



### SAFETY CABINETS CERTIFIED FOR CHEMICALS, ACIDS AND BASES WITH SEPARATE COMPARTMENTS



**MANUFACTURED TO EN 61010-1, EN 16121:2013/A1:2017, EN 16122:2012 STANDARDS - CE MARKING - TÜV CERTIFIED**

Manufactured completely in 10/10 mm pickled steel with acid-proof epoxy powder coating applied in a heat tunnel at 200°C. Paint thickness min. 60µm and max. 250µm per EN ISO 9001:2008.

The cabinets are equipped with two separate compartments, one for acids and one for bases, each equipped with height adjustable drip shelves and bottom sump. The cabinets are equipped with granular activated charcoal filter and Cunctator® device which warns when the filter requires replacement.



#### FEATURES

- Single-piece, corrosion-resistant structure.
- Certified palletised base makes moving the cabinet easier.
- 110° door opening allowing shelf extraction without tilting it.
- Anti-spark corrosion-resistant hidden hinges
- Safety lock with key and removable cylinder
- EN 60335-1, EN 60335-2-80 and EN 50366 compliant IMQ IPX4 electric fan exhaust.
- Power supply: 220/230 volts.
- Electrical absorption: 65W.
- Hazard warning signs.
- Earthing system to prevent eventual discharges.
- Adjustable feet.
- CL insurance for the whole cabinet life



CODE	DESCRIPTION	OUTSIDE DIMENSIONS	INSIDE DIMENSIONS	SHELVES
410 000 578	Safety cabinet for acids, chemicals and alkalis with separate compartments	600 x 500 x h 1998 mm	520 x 440 x h (765+726) mm	2+2
410 003 709	Safety cabinet for acids, chemicals and alkalis with separate compartments	1100 x 500 x h 1117 mm	490 + 490 x 465 x h 1020 mm	2+2

Pictures indicated in this catalogue are representative and not binding for the supplier in terms of layout and colours. They may be subject to changes by the supplier without prior notice.



## SAFETY CABINET CERTIFIED FOR CHEMICALS, ACIDS AND BASES

MANUFACTURED TO EN 61010-1, EN 16121:2013/A1:2017, EN 16122:2012 STANDARDS - CE MARKING - TÜV CERTIFIED

Manufactured completely in 10/10 mm pickled steel with acid-proof epoxy powder coating applied in a heat tunnel at 200°C. Paint thickness min. 60µm and max. 250µm per EN ISO 9001:2008. Perforated grille bottom sump in electrogalvanized and acid-proof epoxy powder coated steel, which functions as a shelf.



### FEATURES

- Single-piece, corrosion-resistant structure.
- Certified palletised base makes moving the cabinet easier.
- 110° door opening allowing shelf extraction without tilting it.
- Anti-spark corrosion-resistant hidden hinges
- Safety lock with key and removable cylinder
- EN 60335-1, EN 60335-2-80 and EN 50366 compliant IMQ IPX4 electric fan exhaust.
- Power supply: 220/230 volts.
- Electrical absorption: 21W.
- Hazard warning signs.
- Earthing system to prevent eventual discharges.
- Adjustable feet.
- CL insurance for the whole cabinet life
- Provision for granular activated charcoal filter.
- Code 410 000 579: single compartment; code 410003710: two separate compartments, one for acids and one for bases.

CODE	DESCRIPTION	OUTSIDE DIMENSIONS	INSIDE DIMENSIONS	SHELVES
410 000 579	Safety cabinet for acids, chemicals and bases - one compartment	600 x 500 x h 700 mm	530 x 465 x h 555 mm	1
410 003 710	Safety cabinet for acids, chemicals and bases - two compartments	900 x 500 x h 700 mm	450 + 450 x 465 x h 555 mm	1



### CERTIFIED SAFETY CABINETS FOR FLAMMABLE PRODUCTS

MANUFACTURED IN COMPLIANCE WITH EN 14470 - EN 16121:2013 / A1:2017 EN 16122:2012 1, TÜV CERTIFIED - FIRE RATING 90 (90 min.) E TYPE 30 (30 min.)

Completely made from 10/10 mm pickled steel with acid-proof epoxy powder coating. Powder coating thickness minimum 60 µm (micron) to maximum 250 µm (micron), per EN ISO 9001 Internal fireproof insulation made of 100% ecological material with high fire resistance. Fire tests performed by accredited laboratories according to EN 1363-1:1999 and UNI EN 1363-1:2001. Equipped with three height-adjustable drip shelves and bottom sump, all in acid-resistant powder-coated electro-galvanised steel.



#### FEATURES

- Certified palletised base makes moving the cabinet easier.
- Single-piece outer structure, corrosion-resistant inner structure.
- Patented "Ignis-lock®" safety locking system that keeps the doors closed in the event of fire.
- Natural internal ventilation system equipped with 2 certified valves that automatically close at  $70 \pm 10^{\circ}\text{C}$  in compliance with safety regulations. The valves are positioned on the top and on the bottom of the cabinet to ensure the automatic release of substances.
- Anti-spark hinges.
- Cylinder safety lock.
- "No smoking" and "Fire" warning stickers on the cabinet doors as required by Italian and European standards (DIN 4844 and ISO 3864).
- Earthing terminal.
- Adjustable feet.
- CL insurance for the whole cabinet life.

**TYPE  
30**

**TYPE  
90**

CODE	DESCRIPTION	OUTSIDE DIMENSIONS	INSIDE DIMENSIONS	SHELVES
410 000 581	Cabinet for inflammables, 2-door • Fire resistance class 90 minutes	1180 x 640 x h 1985 mm	1015 x 445 x h 1685 mm	3
410 000 584	Cabinet for inflammables, 2-door • Fire resistance class 30 minutes	1180 x 640 x h 1985 mm	1015 x 445 x h 1685 mm	3
410 000 585	Cabinet for inflammables, 1-door • Fire resistance class 90 minutes	680 x 640 x h 1985 mm	515 x 445 x h 1685 mm	3
410 000 284	Cabinet for inflammables, 1-door • Fire resistance class 30 minutes	680 x 640 x h 1985 mm	515 x 445 x h 1685 mm	3



## CERTIFIED SAFETY CABINETS FOR FLAMMABLE PRODUCTS

MANUFACTURED TO EN 14470, EN 16121:2013/A1:2017 EN 16122:2012 STANDARDS, TÜV CERTIFIED 90 (90 min.) FIRE RATING

Completely made from 10/10 mm pickled steel with acid-proof epoxy powder coating. Powder coating thickness minimum 60 µm (micron) to maximum 250 µm (micron), per EN ISO 9001 Internal fireproof insulation made of 100% ecological material with high fire resistance. Fire tests performed by accredited laboratories according to EN 1363-1:1999 and UNI EN 1363-1:2001. Equipped with three drip shelves and bottom sump, all in acid-resistant powder-coated electro-galvanised steel.



### FEATURES

- Single-piece outer structure, corrosion-resistant inner structure.
- Natural internal ventilation system equipped with 2 certified valves that automatically close at  $70 \pm 10^{\circ}\text{C}$  in compliance with safety regulations. The valves are positioned on the top and on the bottom of the cabinet to ensure the automatic release of substances.
- Anti-spark hinges.
- Cylinder safety lock.
- "No smoking" and "Fire" warning stickers on the cabinet doors as required by Italian and European standards (DIN 4844 and ISO 3864).
- Earthing terminal.
- CL insurance for the whole cabinet life.

**TYPE  
90**

CODE	DESCRIPTION	OUTSIDE DIMENSIONS	INSIDE DIMENSIONS	SHELVES
410 003 575	Cabinet for inflammables, 2-door • Fire resistance class 90 minutes	1180 x 640 x h 1985 mm	1015 x 445 x h 1685 mm	3





### CABINETS FOR INFLAMMABLE PRODUCTS

MANUFACTURED TO EN 14470-1, EN 16121:2013/A1:2017 EN 16122:2012 STANDARDS, TÜV CERTIFIED  
**90 (90 min.) FIRE RATING**

Completely made from 10/10 mm pickled steel with acid-proof epoxy powder coating. Powder coating thickness minimum 60 µm (micron) to maximum 250 µm (micron), per EN ISO 9001

Hinged door with bottom sump in electro-galvanized and acid-proof epoxy powder-coated steel with grid used as shelf. Internal fireproof insulation made of 100% ecological material with high fire resistance.



410 000 593



410 000 596

#### FEATURES

- Single-piece outer structure, corrosion-resistant inner structure.
- Patented "Ignis-lock®" safety locking system that keeps the doors closed in the event of fire.
- Anti-spark hinges located on the long side of the doors.
- Natural internal ventilation system equipped with 2 certified valves that automatically close at  $70 \pm 10^{\circ}\text{C}$  in compliance with safety regulations. The valves are positioned on the top and on the bottom of the cabinet to ensure the automatic release of substances.
- Bottom sump in electro-galvanized, acid-resistant powder-coated steel with grid used as shelf.
- Cylinder safety lock.
- "No smoking" and "Fire" warning stickers on the cabinet doors as required by Italian and European standards (DIN 4844 and ISO 3864).
- Earthing terminal.
- Adjustable feet.
- CL insurance for the whole cabinet life.

**TYPE  
90**

CODE	DESCRIPTION	OUTSIDE DIMENSIONS	INSIDE DIMENSIONS	SHELVES
410 000 593	Cabinet for inflammable products, 2-doors Fire resistance class 90 minutes	1100 x 510 x 600 h mm	935 x 395 x 445 h mm	1
410 000 596	Cabinet for inflammable products, 1 leaf door Fire resistance class 90 minutes	595 x 510 x 600 h mm	430 x 395 x h 445 h mm	1

## COMBINED CERTIFIED CABINETS FOR CHEMICALS, ACIDS, ALKALIS AND INFLAMMABLES



MANUFACTURED TO EN 14470-1, EN 16121:2013/A1:2017, EN 16122:2012 STANDARDS - TÜV CERTIFIED - CE MARKING - FIRE RATING TYPE 90 (90 min.)

Safety cabinets with ventilation and filtration for the combined storage of chemical products, acids, bases and flammable solids and liquids. Manufactured completely in 10/10 mm pickled steel with acid-proof epoxy powder coating applied in a heat tunnel at 200°C. Coating thickness min. 60µm and max. 250µm per EN ISO 9001:2008.



### FEATURES

- Single-piece outer structure, corrosion-resistant inner structure.
- Cylinder safety lock.
- Hazard warning signs for corrosive, harmful and toxic substances in the upper compartment, and inflammable and smoking prohibited in the lower compartment, per Italian and European safety standards (DIN 4844 and ISO 3864).
- Earthing terminal.
- Adjustable feet.
- CL insurance for the whole cabinet life.

#### Compartment for CHEMICALS, ACIDS AND BASES:

- Height adjustable drip shelves and bottom sump, all in acid-resistant powder-coated electro-galvanized steel.
- 110° door opening for shelf extraction without tilting.
- Carbox® activated charcoal filter
- Only code 410 002 331: EN 60335-1, EN 60335-2-80 and EN 50366 compliant IMQ IPX4 electric fan exhaust with ON light.
- Power supply: 220/230 volts.
- Electrical absorption: 65W.

#### Compartment for FLAMMABLE PRODUCTS:

- Internal fireproof insulation made of 100% ecological material with high fire resistance.
- Patented "Ignis-lock®" safety locking system that keeps the doors closed in the event of fire.
- Natural internal ventilation system equipped with 2 certified valves that automatically close at  $70 \pm 10^\circ\text{C}$  in compliance with safety regulations. The valves are positioned on the top and on the bottom of the cabinet to ensure the automatic release of substances.
- Bottom sump in electro-galvanized, acid-resistant powder-coated steel with grid used as shelf.
- Anti-spark hinges located on the long side of the doors.

**TYPE  
90**

CODE	DESCRIPTION	OUTSIDE DIMENSIONS	INSIDE DIMENSIONS	SHELVES
410 002 330	Combined single-door cabinet for chemicals, acids, bases and flammables • Fire resistance class 90 minutes	595 x 510 x h 1670 mm	Upper compartment: 510 x 474 x h 924 mm Lower compartment: 430 x 395 x h 537 mm	2+1
410 002 331	Combined double-door cabinet for chemicals, acids, bases and flammables • Fire resistance class 90 minutes	1100 x 510 x h 1670 mm	Upper compartment: (490+490) x 465 x h 1020 mm Lower compartment: 935 x 395 x h 445 mm	2+1
410 003 711	Combined three-door cabinet for chemicals, acids, bases and flammables • Fire resistance class 90 minutes	1495 x 510 x h 600 mm	Chemical compartment: (450+450) x 465 x h 555 mm Flammable products compartment: 430 x 395 x h 537 mm	2+1



### CABINETS FOR COMPRESSED GAS CYLINDERS CERTIFIED FOR INDOOR USE

**MANUFACTURED TO EN 14470-2 EN 16121:2013/A1:2017 EN 16122:2012 STANDARDS, TÜV CERTIFIED**

Indoor storage cabinet for compressed gas cylinders. Completely made from 10/10 mm pickled steel with acid-proof epoxy powder coating. Powder coating thickness minimum 60 µm (micron) to maximum 250 µm (micron), per EN ISO 9001 Internal fireproof insulation made of 100% ecological material with high fire resistance.



#### FEATURES

- Single-piece outer structure, corrosion-resistant inner structure.
- Hinged doors.
- Natural internal ventilation system equipped with 2 certified valves that automatically close at  $70 \pm 10^\circ\text{C}$  in compliance with safety regulations. The valves are positioned on the top and on the bottom of the cabinet to ensure the automatic release of substances.
- Gas pipe fitting.
- Space available for reducers and gas flow control panel.
- Cylinder retaining brackets.
- Metal ramp to facilitate gas tank positioning.
- Cylinder safety lock.
- "No smoking" and "Fire" warning stickers on the cabinet doors as required by Italian and European standards (DIN 4844 and ISO 3864).
- Earthing system to prevent eventual discharges.
- Adjustable feet.
- CL insurance for the whole cabinet life.
- Anti-spark hinges with full opening

CODE	DESCRIPTION	OUTSIDE DIMENSIONS	INSIDE DIMENSIONS
410 000 607	Cabinets for compressed gas cylinders certified for indoor use • 2 x 50 litre cylinders Fire rating: 30 minutes (G30)	700 x 600 x h 2015 mm	548 x 445 x h 1787 mm
410 000 608	Cabinets for compressed gas cylinders certified for indoor use • 4 x 50 litre cylinders Fire rating: 30 minutes (G30)	1300 x 600 x h 2015 mm	1165 x 500 x h 1845 mm



### GALVANISED STEEL CONTAINER FOR GAS TANKS STORAGE CABINET

Galvanized steel gas tank storage cabinet. Each module is made with double hinged doors fitted with anti-intrusion lock, load-bearing frame complete with base and roof in galvanized steel, inside the tanks are fastened with retaining chains; each storage cabinet has safety and identification stickers and the modular design allows combinations of one, two or three cabinets.

CODE	DESCRIPTION	DIMENSIONS
411 000 782	Galvanised steel container for storage of 9-12 gas tanks	1130 x 960 x h 2100 mm
411 003 078	Tanks storage cabinet loading ramp	



Meets guidelines for gas cylinder storage per Italian Legislative Decree 81/08

WATCH THE VIDEO



Pictures indicated in this catalogue are representative and not binding for the supplier in terms of layout and colours. They may be subject to changes by the supplier without prior notice.





### GALVANISED RIBBED STEEL CONTAINER FOR GAS TANK STORAGE

Cabinets for outdoor storage of gas cylinders. For storage of single cylinders or on pallets, with natural ventilation and anti-intrusion doors with safety locks.

#### FEATURES

- 3 x walls in galvanized ribbed steel
- Code 411 000 765 1 x double wing door with lock, in tube and hot galvanized electrowelded mesh construction (mesh 40 x 40 mm, wire Ø 4 mm)
- Code 411 000 768 1 x double sliding door with lock, in tube and hot galvanized electrowelded mesh construction (mesh 40 x 40 mm, wire Ø 4 mm)
- Cover in galvanized ribbed steel



411 000 768



411 000 765

CODE	DESCRIPTION	DIMENSIONS
411 000 765	Galvanised steel storage cabinet for gas tanks • without base - double-wing door	3280 x 1570 x h 2350 mm
411 000 768	Galvanised steel storage cabinet for gas tanks • with steel base and ramp - sliding doors	3100 x 1700 x h 2270 mm



The following can be supplied:

- Checker plate steel floor with fork section for code 411 000 765 and hot galvanized access ramp
- Fully painted interior and exterior
- Internal vertical partition (only for cabinets with base)

ON REQUEST

Meets guidelines for gas cylinder storage per Italian Legislative Decree 81/08

# SAFETY CONTAINER FOR POLLUTANTS AND HAZARDOUS SUBSTANCES



Container for storing hazardous substances and pollutants, highly resistant and flexible carbon steel load-bearing frame, with structural panels resting directly on the ground. Equipped with safety sump in bent and profiled carbon steel with reinforced structure to grant perfect watertightness. Sizes, tolerances, rims, chamfers, nominal weight and finishing grade according to UNI parameters.

## RIBBED STEEL



### FEATURES

**WALLS AND ROOF:** in ribbed carbon steel, reaction to fire class A1 (non flammable)

*Equipped with:*

**Two-leaf hinged door:** in ribbed carbon steel, reaction to fire class A1 (non flammable)

or

**Two sliding doors:** in ribbed carbon steel, reaction to fire class A1 (non flammable)

## INSULATED CONTAINERS



### FEATURES

**WALLS:** 50 or 40 mm sandwich panels made of WASHABLE prepainted RAL 9002 white/grey galvanised steel sheets sandwiching polyurethane insulation.

**Reaction to fire:** CLASS F (inflammable)

**ROOF:** 40 mm (+40 m rib) ribbed insulated sandwich panels made of prepainted galvanised steel sheets, sandwiching polyurethane insulation.

**Reaction to fire:** CLASS F (inflammable)

*Equipped with:*

**Dual-leaf door:** made from RAL 9010 pre-painted aluminium sandwich panels, complete with handle and Yale lock with three keys.

or

**Dual sliding door:** made with insulated PU panels (as per walls) with key locking; complete with painted galvanised sheet-metal finishing profiles, bottom sliding guides (rails and rollers by Rolling Center for greater product life and reliability).

### INSULATED SANDWICH PANEL SPECIFICATIONS

**WALLS AND ROOF:** ribbed galvanised carbon steel sandwiching polyurethane insulation.

- Steel support plates galvanised to EN 10346:2009 (SENDZMIR process). Continuous line acrylic prepainting with polyester resin. WHITE/GREY COLOUR SIMILAR TO RAL 9002.
- PU resin-based foam (per DIN 4102), density 40 kg/m<sup>3</sup> (guaranteed 35-40 kg/m<sup>3</sup>).
- Wall U value= 0.64W/m<sup>2</sup>K. Lid U-value =0.54 W/m<sup>2</sup>K or wall U value= 0.49W/m<sup>2</sup>K.
- Lid U value= 0.54 W/m<sup>2</sup>K.

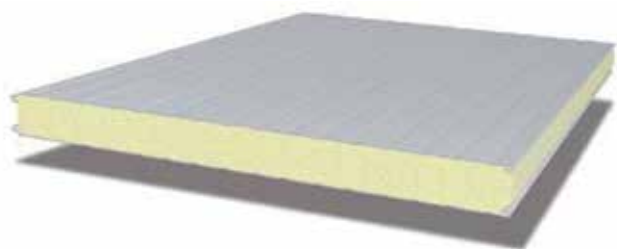

## CONTAINER WITH REI/EI PANELS



## FEATURES

**WALLS: EI 120 certified panels** (EN 14509 and EN 13501).  
 (\*) With 100 mm thickness. Panels formed with two galvanised steel sheets, primed and painted in a white/grey colour similar to RAL 9002. The sheet metal sandwiches a 120 kg/m<sup>3</sup> - CLASS A2-S1 d0 mineral wool batt. The mineral wool is bonded to the sheet metal with PU adhesive. Correctly installed panels: at the male-female junction, seam screws must be installed on both sides, if required by the certificate.

**FLAT ROOF: REI 120 certified panels** (EN 14509 and EN 13501).

(\*) With 100 mm thickness. Panels formed with two galvanised steel sheets, primed and painted in a white/grey colour similar to RAL 9002. The sheet metal sandwiches a 120 kg/m<sup>3</sup> - CLASS A2-S1 d0 mineral wool batt. The mineral wool is bonded to the sheet metal with PU adhesive. The tops of the panels are closed with sheet-metal profiles to prevent rainwater ingress.

Equipped with:

**Dual-leaf hinged door: REI 120 certified** key lockable.

Door with high-strength steel angle section on three sides and lower spacer, gloss RAL 7035 powder coated and fitted with folding anchor bolts and holes for plugs, spring hinge, total leaf thickness 63 mm with two sheets of RAL 7035 prepainted galvanised sheet steel with peel-off film sandwiching fireproof insulation, intumescent perimeter gasket between leaf and frame, two retention catches, CE certified lock with latch and deadbolt, black safety handle in fireproof polyamide with steel core, escutcheon and patented keys, plate with conformity marking, sticker with data, booklet with installation and use and maintenance instructions, copy of type approval and declaration of conformity.

or

**Two-leaf sliding door: with EI 120 certified panels** (new European standards).

(\*) As per walls with key locking; complete with painted galvanised sheet-metal finishing profiles, bottom sliding guides (rails and rollers by Rolling Center for greater product life and reliability)

(\*) Note that, per European Standards, wall panels certified as EI (E= Integrity (to smoke passage) – I= Insulation) cannot be used for roofs.

Roof panels must be certified REI (R= Resistance to mechanical impact (during a fire) – E= Integrity – I= Insulation).

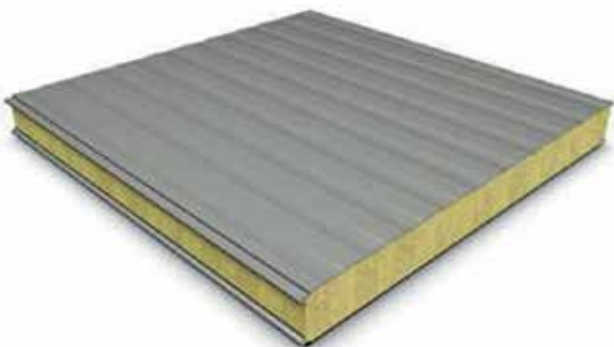

## MINERAL WOOL PANEL SPECIFICATIONS

100 mm thick panels formed with two galvanised steel sheets, primed and painted in a white/grey colour similar to RAL 9002. The sheet metal sandwiches a 120 kg/m<sup>3</sup> - CLASS A2-S1 d0 mineral wool batt.

WATCH  
THE VIDEO



## TECHNICAL SPECIFICATIONS OF STEEL, INSULATED AND REI/EI PANELS



Provision for fastening to the ground with plugs (responsibility of the user)  
Movement by forklift truck equipped with fork extensions and of suitable capacity (*only with the container empty*).



Movement and handling via crane with base attachment (*only with the container empty*).



Continuous 80 mm runners for ground bearing (same width as container), suitably spaced for greater stability and improved levelling.



Flooring in hot-dip galvanised mesh, 34 x 76 mm flat, 25 x 2 mm (carbon steel).



Natural ventilation pursuant to Italian Ministerial Decree 18/05/95, with fixed-fin aluminium grilles (NON REI) with insect mesh, equivalent to 1/30 of the surface area, positioned opposite each other for improved air recirculation.



Guttering and downpipes (to ground level) in painted, galvanised profile sections; the tubular downpipes are welded to the roof and sump to increase container rigidity.

### OTHER TECHNICAL SPECIFICATIONS

Angle sections, roof profiles and U profiles (for wall containment) in galvanised or painted steel.

Watertight spill sump in 2.0 mm thick galvanised carbon steel, sized on the basis of the materials storage per Italian Ministerial Decree 18/05/1995.



**TEST:** Registration and testing with hydraulic test at full load for 48 consecutive hours at atmospheric pressure at room temperature. Design and technical protocol compliant with CE regulations.

The storage containers can be OPEN SPACE, or else equipped with internal shelving for storage of drums on europallets or 1000 l IBCs, or else with CANTILEVER type shelving for the storage of small containers

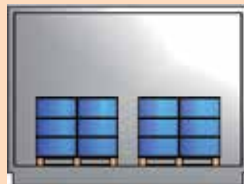
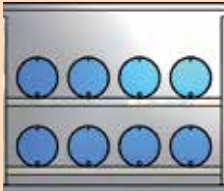

The shelving is completely removable and height adjustable, and is also fitted with pallet-stop tubes to prevent them falling.



### OPTIONS

All our containers are available with the following on request:

- **GREATER FLOOR LOAD CAPACITY**
- **TROPICAL-SPECIFICATION ROOF** to provide thermal insulation for the roof and protect the container from overheating due to solar radiation
- **CONVECTION HEATER** to heat the interior of the container during winter and keep the stored substances above their freezing points. Available also in ATEX version
- **9000 BTU/H or 12000 BTU/H AIR CONDITIONER** to keep the temperature inside the container below the flash point of the stored substances. Available also in ATEX version
- **LIGHTING SYSTEM** also available in ATEX version
- **ELECTRICAL SYSTEMS** also available in ATEX version
- **ACCESS RAMP**

Welder qualification per EN ISO 9606-1:2013.  
Welding process qualification per EN ISO 15614-1:2012.  
Welding processes per EN ISO 3834-2:2006.

# SECURITY STORAGE CONTAINER FOR OUTDOOR USAGE "OPEN SPACE"



CUSTOMIZABLE  
PRODUCT

## CARBON STEEL CONTAINER (FLAT ROOF)



CODE	MAX. OUTER DIMENSIONS	DOUBLE WING DOOR (PASSAGE)
411 000 619	2635 x 2100 x h 2390 mm	2475 x h 2000 mm
411 000 620	3560 x 2100 x h 2390 mm	3370 x h 2000 mm
411 000 621	4755 x 2100 x h 2390 mm	1655 x h 2000 mm
411 000 622	5170 x 2100 x h 2390 mm	2475 x h 2000 mm
411 000 623	6885 x 2100 x h 2390 mm	1655 x h 2000 mm

## INSULATED CONTAINER



CODE	MAX. OUTER DIMENSIONS	DOUBLE WING DOOR (PASSAGE)
411 000 624	2130 x 2130 x h 2520 mm	1680 x h 2000 mm
411 000 625	3130 x 2130 x h 2520 mm	1890 x h 2000 mm
411 000 626	4130 x 2130 x h 2520 mm	1890 x h 2000 mm
411 000 627	5130 x 2130 x h 2520 mm	1890 x h 2000 mm
411 000 628	6130 x 2130 x h 2520 mm	1890 x h 2000 mm
411 000 629	7130 x 2130 x h 2520 mm	1890 x h 2000 mm

## CONTAINER WITH REI/EI PANELS



CODE	MAX. OUTER DIMENSIONS	DOUBLE WING DOOR (PASSAGE)
411 000 630	2130 x 2110 x h 2640 mm	1680 x h 2100 mm
411 000 631	3130 x 2110 x h 2640 mm	1880 x h 2100 mm
411 000 632	4130 x 2110 x h 2640 mm	1880 x h 2100 mm
411 000 633	5130 x 2110 x h 2640 mm	1880 x h 2100 mm
411 000 634	6130 x 2110 x h 2640 mm	1880 x h 2100 mm
411 000 635	7130 x 2110 x h 2640 mm	1880 x h 2100 mm

### STORAGE CONTAINER FOR HORIZONTAL DRUMS

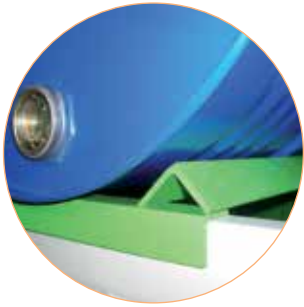

#### 8 X 200 LITRE DRUMS, HORIZONTAL

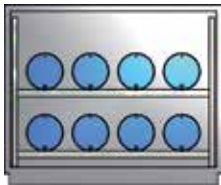

MODEL	WING DOORS	SLIDING DOORS
STEEL	<b>411 000 688</b> 3200 x 1550 x h 2600 mm	<b>411 000 691</b> 3200 x 1620 x h 2600 mm
INSULATED	<b>411 000 689</b> 3200 x 1630 x h 2600 mm	<b>411 000 692</b> 3230 x 1660 x h 2600 mm
REI/EI	-	<b>411 000 693</b> 3360 x 1800 x h 2600 mm

#### 12 X 200 LITRE DRUMS, HORIZONTAL

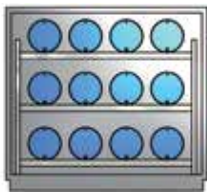

MODEL	WING DOORS	SLIDING DOORS
STEEL	<b>411 000 695</b> 3200 x 1550 x h 3200 mm	<b>411 000 698</b> 3200 x 1620 x h 3200 mm
INSULATED	-	<b>411 000 699</b> 3200 x 1640 x h 3200 mm
REI/EI	-	<b>411 000 700</b> 3360 x 1800 x h 3200 mm

#### 16 X 200 LITRE DRUMS, HORIZONTAL

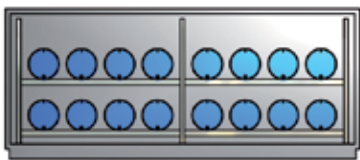

MODEL	SLIDING DOORS
STEEL	<b>411 000 702</b> 5960 x 1620 x h 2600 mm
INSULATED	<b>411 000 703</b> 6030 x 1640 x h 2600 mm
REI/EI	<b>411 000 704</b> 6160 x 1880 x h 2600 mm

#### 24 X 200 LITRE DRUMS, HORIZONTAL

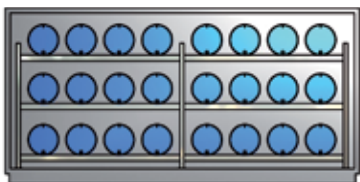

MODEL	SLIDING DOORS
STEEL	<b>411 000 706</b> 5980 x 1680 x h 3330 mm
INSULATED	<b>411 000 707</b> 6030 x 1695 x h 3330 mm
REI/EI	<b>411 000 708</b> 6160 x 1880 x h 3200 mm

Pictures indicated in this catalogue are representative and not binding for the supplier in terms of layout and colours. They may be subject to changes by the supplier without prior notice.



# VERTICAL DRUMS CONTAINER



## 6 x 200 LITRE DRUMS, VERTICAL, ON 800 X 1200 mm PALLET or 8 x 200 LITRE DRUMS, VERTICAL, ON 1200 X 1200 mm PALLET

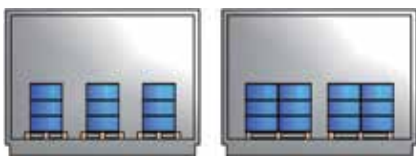

MODEL	WING DOORS	SLIDING DOORS
STEEL	<b>411 000 636</b> 3040 x 1630 x h 2470 mm	<b>411 000 639</b> 3040 x 1680 x h 2470 mm
INSULATED	<b>411 000 637</b> 3130 x 1630 x h 2500 mm	<b>411 000 640</b> 3130 x 1695 x h 2440 mm
REI/EI	-	<b>411 000 641</b> 3160 x 1870 x h 2490 mm

## 12 x 200 LITRE DRUMS, VERTICAL, ON 800 X 1200 mm PALLET or 16 x 200 LITRE DRUMS, VERTICAL, ON 1200 X 1200 mm PALLET

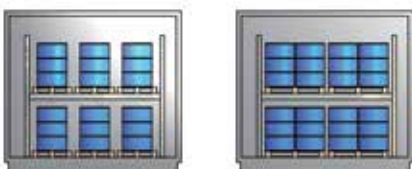

MODEL	WING DOORS	SLIDING DOORS
STEEL	<b>411 000 643</b> 3160 x 1680 x h 2990 mm	<b>411 000 646</b> 3160 x 1680 x h 2990 mm
INSULATED	-	<b>411 000 647</b> 3230 x 1695 x h 2960 mm
REI/EI	-	<b>411 000 648</b> 3360 x 1870 x h 3000 mm

Pictures indicated in this catalogue are representative and not binding for the supplier in terms of layout and colours. They may be subject to changes by the supplier without prior notice.



### 12 x 200 LITRE DRUMS, VERTICAL, ON 800 X 1200 mm PALLET or 16 x 200 LITRE DRUMS, VERTICAL, ON 1200 X 1200 mm PALLET

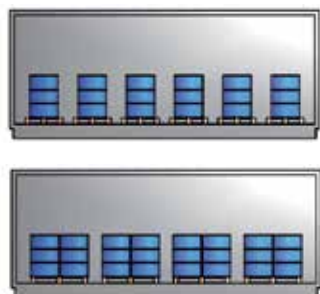

MODEL	SLIDING DOORS
STEEL	<b>411 000 654</b> 5960 x 1680 x h 2420 mm
INSULATED	<b>411 000 655</b> 5630 x 1695 x h 2440 mm
REI/EI	<b>411 000 656</b> 6160 x 1870 x h 2490 mm

### 24 x 200 LITRE DRUMS, VERTICAL, ON 800 X 1200 mm PALLET or 32 x 200 LITRE DRUMS, VERTICAL, ON 1200 X 1200 mm PALLET



MODEL	SLIDING DOORS
STEEL	<b>411 000 658</b> 5980 x 1680 x h 2990 mm
INSULATED	<b>411 000 659</b> 6030 x 1695 x h 2960 mm
REI/EI	<b>411 000 660</b> 6160 x 1870 x h 3000 mm

### 36 x 200 LITRE DRUMS, VERTICAL, ON 800 X 1200 mm PALLET or 48 x 200 LITRE DRUMS, VERTICAL, ON 1200 X 1200 mm PALLET



MODEL	SLIDING DOORS
STEEL	<b>411 000 662</b> 8920 x 1680 x h 2990 mm
INSULATED	<b>411 000 663</b> 8830 x 1790 x h 2960 mm
REI/EI	<b>411 000 664</b> 8960 x 1870 x h 3000 mm

# STORAGE CONTAINER FOR 1000 LITRE IBCs



## 4 x 1000 LITRE IBCs



MODEL	WING DOORS	SLIDING DOORS
STEEL	<b>411 000 710</b> 3160 x 1630 x h 3480 mm	<b>411 000 713</b> 3160 x 1680 x h 3480 mm
INSULATED	-	<b>411 000 714</b> 3230 x 1695 x h 3460 mm
REI/EI	-	<b>411 000 715</b> 3360 x 1870 x h 3490 mm

## 3 x 1000 LITRE IBCs



MODEL	WING DOORS	SLIDING DOORS
STEEL	<b>411 000 717</b> 3530 x 1630 x h 2550 mm	<b>411 003 204</b> 4540 x 1580 x h 2500 mm
INSULATED	-	<b>411 003 205</b> 4130 x 1695 x h 2440 mm
REI/EI	-	<b>411 003 206</b> 4160 x 1860 x h 2520 mm

## 6 x 1000 LITRE IBCs



MODEL	SLIDING DOORS
STEEL	<b>411 003 207</b> 4110 x 1680 x h 3490 mm
INSULATED	<b>411 003 208</b> 4130 x 1695 x h 3490 mm
REI/EI	<b>411 003 209</b> 4260 x 1870 x h 3500 mm

Pictures indicated in this catalogue are representative and not binding for the supplier in terms of layout and colours. They may be subject to changes by the supplier without prior notice.

#### 4 x 1000 LITRE IBCs



MODEL	SLIDING DOORS
STEEL	<b>411 000 725</b> 5170 x 1680 x h 2470 mm
INSULATED	<b>411 000 726</b> 5130 x 1695 x h 2440 mm
REI/EI	<b>411 000 727</b> 5160 x 1870 x h 2470 mm

#### 6 x 1000 LITRE IBCs



MODEL	SLIDING DOORS
STEEL	<b>411 000 733</b> 6960 x 1630 x h 2490 mm
INSULATED	<b>411 000 734</b> 7130 x 1695 x h 2440 mm
REI/EI	<b>411 000 735</b> 7160 x 1870 x h 2490 mm

#### 8 x 1000 LITRE IBCs



MODEL	SLIDING DOORS
STEEL	<b>411 000 729</b> 5980 x 1680 x h 3480 mm
INSULATED	<b>411 000 730</b> 5930 x 1695 x h 3460 mm
REI/EI	<b>411 000 731</b> 6160 x 1870 x h 3490 mm

#### 12 x 1000 LITRE IBCs



MODEL	SLIDING DOORS
STEEL	<b>411 000 737</b> 7770 x 1680 x h 3490 mm
INSULATED	<b>411 000 738</b> 7830 x 1695 x h 3490 mm
REI/EI	<b>411 000 739</b> 7960 x 1870 x h 3500 mm



Pictures indicated in this catalogue are representative and not binding for the supplier in terms of layout and colours. They may be subject to changes by the supplier without prior notice.

## FORKLIFT TRUCK STALL



411 000 369

Forklift truck storage cabinet made from insulated panels. Natural ventilation grids corresponding to 1/30 of the floor surface. Bottom containment sump, also with acid-resistant coating on request, and high-capacity floor grid. Swing or wing front door. Access ramp.



411 002 353



CODE	OUTSIDE DIMENSIONS	DOOR MODEL
411 000 369	4030 x 2380 x h 2800 mm	Tilt door
411 002 353	4030 x 2380 x h 2800 mm	Hinged door



The following can be supplied:

- Perimeter shelves
- Automatic powder fire extinguisher, 6 kg
- Standard or ATEX lighting system
- Standard or ATEX climate control system
- Standard or ATEX forced ventilation system
- Exterior painting for sheet-metal containers

ON REQUEST



### JERRYCANS

Containers for storage of liquids, constructed in plastic or metal, equipped with cap or cover, are ideal for storing and transporting any type of liquids.

When used for transporting hazardous goods (pursuant to 67/548/EC), they must be ADR certified or certified for transport regulations.

#### POLYETHYLENE (PE) JERRYCANS FOR FLAMMABLES ADR APPROVED



- High visibility red polyethylene (PE) jerrycans
- ADR approved in compliance with European Directives
- Flexible discharge spout
- Robust and shock-resistant

CODE	DESCRIPTION	TYPE APPROVAL	CAPACITY
412 003 968	Polyethylene (PE) jerrycan for flammable liquids ADR (DGT) approved • 250 x 145 x h 270 mm	3H 1/Y 1.2/180	5 L
412 003 969	Polyethylene (PE) jerrycan for flammable liquids ADR (DGT) approved • 270 x 145 x h 375 mm	3H 1/Y 1.2/180	10 L

#### POLYETHYLENE (PE) JERRYCAN FOR STORAGE OF USED MINERAL OIL



- Extremely versatile and safe jerrycan
- Designed to collect mineral oil directly on site
- With handles and wheel to facilitate full load handling
- Stackable
- For oil collecting and suction

CODE	DESCRIPTION	CAPACITY
412 000 788	Polyethylene (PE) jerrycan for storage of used mineral oil 570 x 370 x h 280 mm	36 L

#### POLYETHYLENE (PE) JERRYCANS FOR DRAINING ENGINE OIL



- Jerrycans ideal for draining used engine oil from cars and motorbikes
- Shape and capacity designed specifically for this kind of operation
- The 12 L model is equipped with accessories to be used for tank refilling and top-up

CODE	DESCRIPTION	CAPACITY
412 000 789	Polyethylene (PE) jerrycan for draining engine oil 430 x 295 x h 130 mm	6 L
412 000 790	Polyethylene (PE) jerrycan for draining engine oil 570 x 320 x h 130 mm	10 L
CODE	DESCRIPTION	CAPACITY
412 000 791	Polyethylene (PE) jerrycan for draining and topping up engine oil 570 x 370 x h 135 mm	12 L

Pictures indicated in this catalogue are representative and not binding for the supplier in terms of layout and colours. They may be subject to changes by the supplier without prior notice.

## METAL JERRYCANS FOR FLAMMABLE LIQUIDS ADR APPROVED



- Metal jerrycans to contain and transport flammable liquids.
- All models are ADR approved.
- Each jerrycan can be equipped with pouring spout accessory

CODE	DESCRIPTION	TYPE APPROVAL	CAPACITY
412 003 953	Metal ADR (DGT) approved jerrycan for flammable liquids • 120 x 230 x h 320 mm	3A1/Y/100/D/BAM	5 L
412 003 954	Metal jerrycan for flammable liquids, ADR approved 165 x 280 x h 345 mm	3A1/Y/100/D/BAM	10 L
412 003 955	Metal jerrycan for flammable liquids, ADR approved 165 x 345 x h 470 mm	3A1/Y/100/D/BAM	20 L
CODE	DESCRIPTION		
412 003 956	Flexible spout		

## POLYETHYLENE (PE) JERRYCANS FOR WATER



Translucent white PE jerrycans with cap with safety ring; tough and strong, they are food safe.



412 003 970-1-2-3-4



412 003 975-6

CODE	DESCRIPTION	CAPACITY
412 003 970	PE jerrycan for water	10 L
412 003 971	PE jerrycan for water	15 L
412 003 972	PE jerrycan for water	20 L
412 003 973	PE jerrycan for water	25 L
412 003 974	PE jerrycan for water	30 L
412 003 975	PE jerrycan for water with tap	10 L
412 003 976	PE jerrycan for water with tap	20 L

## STAINLESS STEEL SAFETY CONTAINERS

Ensure operator safety when working with flammable liquids and other hazardous goods in laboratories and industry. Reusable and exceptionally durable. Chemical-resistant, made from high quality stainless steel and Teflon (PTFE). Explosion-proof, with flame traps, pressure control valves and automatic safety locker caps/devices. Compliant with the main technical standards (e.g. DIN and BAM). Certified according to main TÜV methods. Recommended by governmental occupational health and safety bodies.

### STAINLESS STEEL SAFETY CONTAINERS FOR FLAMMABLE LIQUIDS

- Safety container for industrial use, made of stainless steel (thickness 0.6 mm)
- Ergonomic powder-painted aluminium handle
- Teflon (PTFE) gaskets
- Flame trap and pressure control valve (0.3 bar) in spout or screw cap, depending on the model.



412 002 365      412 002 366 - 412 002 367

CODE	DESCRIPTION	CAPACITY
412 000 800	Stainless steel safety container with metering device • Ø 110 x h 230 mm	1 L
412 000 801	Stainless steel safety container with metering device • Ø 130 x h 290 mm	2 L
412 000 802	Stainless steel safety container with metering device • Ø 165 x h 400 mm	5 L
412 000 803	Stainless steel safety container with screw cap and pressure valve • Ø 110 x h 230 mm	1 L
412 000 804	Stainless steel safety container with screw cap and pressure valve • Ø 130 x h 290 mm	2 L
412 000 805	Stainless steel safety container with screw cap and pressure valve • Ø 165 x h 400 mm	5 L

CODE	DESCRIPTION
412 002 365	Stainless steel plug-in funnel (Ø 23 mm)
412 002 366	Soaking tray with pump (h 260 mm)
412 002 367	Soaking tray with pump (h 320 mm)

### STAINLESS STEEL SAFETY JERRYCANS FOR FLAMMABLE LIQUIDS

- Safety jerrycans for storage, filling and metering of flammable liquids, high chemical resistance, in high quality stainless steel (0.8 mm thick)
- Handhold in solid stainless steel
- Teflon (PTFE) gaskets
- Equipped with removable flame traps
- Pressure control valve (0.3 bar) in self-closing spout or screw cap, depending on the model.



412 002 368

412 002 369

CODE	DESCRIPTION	CAPACITY
412 000 806	Stainless steel safety jerrycan with metering device and pressure valve 200 x 130 x h 310 mm	5 L
412 000 807	Stainless steel safety jerrycan with metering device and pressure valve 280 x 130 x h 380 mm	10 L
412 000 808	Stainless steel safety jerrycan with screw cap and pressure valve 200 x 130 x h 310 mm	5 L
412 000 809	Stainless steel safety jerrycan with screw cap and pressure valve 280 x 130 x h 380 mm	10 L
412 000 810	Stainless steel safety jerrycan with screw cap and pressure valve 345 x 175 x h 470 mm	20 L
412 002 369	Stainless steel jerrycan with spout with automatic safety locker and separate ventilation. Horizontal use • 280 x 130 x h 380 mm	10 L

CODE	DESCRIPTION
412 002 368	Inclined funnel (Ø 34 mm)

## STAINLESS STEEL SAFETY BARREL FOR FLAMMABLE LIQUIDS

- Stainless steel barrels for storage, refilling and metering of flammable liquids (thickness from 0.8 to 1.5 mm)
- Teflon (PTFE) gaskets and flame trap
- Equipped with pressure control valve (approx. 0.3 bar) in the spout or screw cap, depending on the model



412 002 370

CODE	DESCRIPTION	CAPACITY
412 000 811	Stainless-steel barrel with automatic safety locker cap, metering cock and pressure control valve • Ø 260 x h 350 mm	10 L
412 000 812	Stainless-steel barrel with automatic safety locker cap, metering cock and pressure control valve • Ø 300 x h 530 mm	25 L
412 000 813	Stainless-steel barrel with automatic safety locker cap, metering cock and pressure control valve • Ø 380 x h 600 mm	50 L
412 000 814	Stainless-steel barrel with screw cap and pressure control valve • Ø 260 x h 350 mm	10 L
412 000 815	Stainless-steel barrel with screw cap and pressure control valve • Ø 300 x h 530 mm	25 L
412 000 816	Stainless-steel barrel with screw cap and pressure control valve • Ø 380 x h 600 mm	50 L
412 000 817	Stainless-steel barrel with automatic safety locker cap, metering cock and level indicator Ø 260 x h 350 mm	10 L
412 000 818	Stainless-steel barrel with automatic safety locker cap, metering cock and level indicator Ø 300 x h 530 mm	25 L
412 000 819	Stainless-steel barrel with automatic safety locker cap, metering cock and level indicator Ø 380 x h 600 mm	50 L

CODE	DESCRIPTION
412 002 370	Stainless steel plug-in funnel (Ø 34 mm)

## STAINLESS STEEL ADR APPROVED CONTAINERS FOR FLAMMABLE LIQUIDS

- Safety containers compliant with ADR, RID, IMDG, ICAO-TI standards
- Special containers for safe transportation of hazardous goods by truck, ship, plane or train
- Made from stainless steel (material thickness 0.6 - 1.2 mm).
- Teflon (PTFE) gaskets
- With screw cap



412 002 365

412 002 370

412 002 368

CODE	DESCRIPTION	TYPE APPROVAL	CAPACITY
412 000 820	Stainless steel type-approved barrel • Ø 111 x h 235 mm	1A1/X2.0/400/...	1 L
412 000 821	Stainless steel type-approved barrel • Ø 131 x h 295 mm	1A1/X2.0/400/...	2 L
412 000 822	Stainless steel type-approved barrel • Ø 165 x h 400 mm	1A1/X2.0/400/...	5 L
412 000 823	Stainless steel type-approved jerrycan 130 x 200 x h 310 mm	3A1/X1.6/300/...	5 L
412 000 824	Stainless steel type-approved jerrycan 130 x 280 x h 380 mm	3A1/X1.6/300/...	10 L
412 000 826	Stainless steel type-approved barrel. Fitted with separate ventilation • Ø 300 x 530 mm	1A1/X1.6/400/...	25 L

CODE	DESCRIPTION
412 002 365	Stainless steel plug-in funnel (Ø 23 mm)
412 002 370	Stainless steel plug-in funnel (Ø 34 mm)
412 002 368	Inclined funnel (Ø 34 mm)



## SAFETY CONTAINERS

Safety containers are a basic component of safety in working areas. Thanks to their user-friendliness, they are indispensable for ensuring operator safety in laboratories where flammables are used. They can safely store hazardous liquids and keep vapours under control, thus reducing fire risk. Made from sturdy coated steel structure (0.6 mm thick). Resistant to chemicals, oil, petrol, paraffin and other substances. Double welding at bottom and top to guarantee excellent shock resistance.

### CONTAINERS WITH AUTOMATIC SAFETY LOCKER



- Constructed from leaded sheet steel, with a single opening for pouring and filling. Suitable for transporting flammable liquids which must be poured into containers with a large opening.
- The 4-litre model has a handle with a spring closure opening; the larger model is also equipped with a swinging handle to facilitate transport.

CODE	DESCRIPTION	CAPACITY
412 003 038	Container with automatic safety locker cover • Ø 241 x h 279 mm	4 L
412 003 138	Container with automatic safety locker cover • Ø 298 x h 429 mm	19 L

### CONTAINERS WITH HOSE



- With two openings, one for draining and one for filling. They come complete with a flexible metal hose, ideal for pouring accurately and without drips into small openings such as bottles, sponge containers and small engines.
- The rear opening allows easy filling.

CODE	DESCRIPTION	CAPACITY
412 003 139	Container with flexible dispenser • Ø 241 x h 267 mm	4 L
412 003 198	Container with flexible dispenser • Ø 298 x h 305 mm	9.5 L

### CONTAINERS WITH TAP



- Complete with self-closing tap and filling plug with pressure relief valve, anti-vacuum device and dual-mesh flame barrier.

CODE	DESCRIPTION	CAPACITY
412 003 199	Container with tap • Ø 298 x h 292 mm	9.5 L
412 003 039	Container with tap • Ø 298 x h 429 mm	19 L

### FUNNEL FOR SAFETY CONTAINERS



- Galvanised steel funnel for steel containers.

CODE	DESCRIPTION
412 003 136	Funnel for safety container • Ø 25 x h 356 mm

## PLUNGER CONTAINERS



- Allow safe, low-cost handling of flammable liquids.
- Help streamline cleaning operations with sponges and rags. By pushing the upper plate downwards with the sponge, the liquid is pumped upwards moistening it, then allowing the excess liquid to return to the container.
- The pumping assembly is in brass, while the upper plate mesh functions as a flame barrier.

CODE	DESCRIPTION	CAPACITY
412 003 140	Suction container • Ø 125 x h 133 mm	0.5 L
412 003 023	Suction container • Ø 185 x h 187 mm	2 L
412 003 094	Suction container • Ø 185 x h 267 mm	4 L

## WORKBENCH WASHING BASINS



- Used for cleaning small components with solvents. The flame trap plate is immersed with the component and the spring returns the plate to the surface after rinsing.
- A fuse, which melts at 70°C, causes the cover to close automatically in the event of a fire.

CODE	DESCRIPTION	CAPACITY
412 003 141	Bench washing basin • Ø 238 x h 114 mm	4 L
412 003 200	Bench washing basin • Ø 292 x h 149 mm	8 L

## WASHING BUCKETS



- Facilitate and speeds up washing small semi-assembled parts, they are easy to move as dictated by production requirements.
- Manual cover which remains open during use, but equipped with an automatic safety locker with a 70°C fuse in the event of fire.

CODE	DESCRIPTION	CAPACITY
412 003 201	Washing bucket • Ø 238 x h 254 mm	8 L
412 003 142	Washing bucket • Ø 349 x h 330 mm	19 L

## OILY WASTE CONTAINER



- Opens to a maximum angle of 60° and remains closed when not in use, thus isolating its contents from combustion sources and limiting oxygen in order to almost completely eliminate the risk of spontaneous combustion.
- The safe method for containing oil rags, cloths etc.

CODE	DESCRIPTION	CAPACITY
412 003 202	Pedal-operated oily waste container • Ø 302 x h 403 mm	20 L
412 003 143	Oily waste container • Ø 408 x h 514 mm	52 L

## POLYETHYLENE (PE) DRUMS AND JERRYCANS ADR APPROVED

Drums and jerrycans made of high density high-molecular-weight polyethylene (HDPE-HMW), with strong resistance to chemicals. Type- approved, they are ideal for the safe transport of hazardous materials in compliance with relevant regulations by land (ADR-RID), sea (IMO-IMDG), air (IATA-ICAO).

### TYPE-APPROVED RECTANGULAR-SECTION JERRYCAN WITH NARROW MOUTH OPENING



- Rectangular jerrycan with closing cap
- Special slot-in shape for excellent stability and safe stacking during storage and transport
- Important details, including the handle with end shaping and no corners on the top makes the jerrycan very easy to empty
- Food-safe

CODE	DESCRIPTION	CAPACITY	TYPE APPROVAL
412 000 851	Type-approved rectangular-section jerrycan with narrow mouth opening • 188 x 162 x h 248 mm • cap D 51 M	5 L	3H 1/Y/...
412 000 852	Type-approved rectangular-section jerrycan with narrow mouth opening • 230 x 195 x h 325 mm • cap D 51 M	11 L	3H 1/Y/...
412 000 853	Type-approved rectangular-section jerrycan with narrow mouth opening • 295 x 243 x h 397 mm • cap D 51 M	20 L	3H 1/Y/...
412 000 854	Type-approved rectangular-section jerrycan with narrow mouth opening • 295 x 243 x h 459 mm • cap D 51 M	25 L	3H 1/Y/...
412 000 855	Type-approved rectangular-section jerrycan with narrow mouth opening • 375 x 284 x h 397 mm • cap D 61 M	30 L	3H 1/X/...

### TYPE-APPROVED CIRCULAR-SECTION JERRYCAN WITH NARROW MOUTH OPENING



- Round jerrycan with two self sealing caps
- Two handles on the top for easy drum handling and emptying
- Food-safe

CODE	DESCRIPTION	CAPACITY	TYPE APPROVAL
412 000 856	Type-approved circular-section jerrycan with narrow mouth opening • Ø 560 h 400 mm • cap D 51 M	50 L	1H 1/Y/...

### ACCESSORIES FOR NARROW MOUTH JERRYCANS



CODE	DESCRIPTION
412 000 857	D 51 F cap with gasket
412 000 858	D 61 F cap with gasket
412 000 859	D 51 F cap with vent
412 000 860	D 61 F cap with vent
412 000 861	D 51 F cap with tap
412 000 862	D 61 F cap with tap
412 002 371	Stainless steel funnel (Ø 140 mm) with cover and flame trap (DIN 51)
412 002 372	Stainless steel funnel (Ø 140 mm) with cover and flame trap (DIN 61)
412 002 373	Stainless steel funnel (Ø 190 mm) with cover and flame trap (DIN 61)

## TYPE-APPROVED CIRCULAR SECTION DRUM WITH NARROW MOUTH OPENING



- Round drum with two threaded bungs
- Upper reinforcing ring designed to guarantee easy handling with standard drum gripping tools: standard jaws, lifting devices, forklifts
- Food-safe

CODE	DESCRIPTION	CAPACITY	TYPE APPROVAL
412 000 863	Type-approved circular section drum with narrow mouth opening • Ø 580 x h 935 mm • cap 56 x 4F	220 L	1H 1/Y/...

## TYPE-APPROVED RECTANGULAR-SECTION DRUM WITH NARROW MOUTH OPENING



- Rectangular drum with two threaded bungs
- The rectangular shape optimises storage and pallet filling
- Food-safe

CODE	DESCRIPTION	CAPACITY	TYPE APPROVAL
412 000 864	Type-approved rectangular-section drum with narrow mouth opening • 330 x 395 x h 660 mm cap 56 x 4F	60 L	3H 1/Y1.9/200
412 003 282	Type-approved narrow mouth drum Ø 500 x h 800 mm cap 56 x 4F	120 L	1H 1/X1.3/250

## ACCESSORIES FOR NARROW MOUTH DRUMS





CODE	DESCRIPTION
412 000 865	Red plastic cap
412 000 866	Cap 56 x 4 M
412 000 867	Cap 56 x 4 M with vent
412 000 868	3/4" tap with reducer
412 000 869	Adaptor 56 x 4 M - 2" F
412 002 374	SS funnel w. buttress thread, closure head, flame trap (Ø 140)
412 002 375	SS funnel w. buttress thread, closure head, flame trap (Ø 190)



### TYPE-APPROVED WIDE MOUTH DRUMS FOR SOLID TRANSPORT



- Total opening drum
- With removable cover
- 30 and 60 L drums have two carry handles on the sides
- Designed for optimal shock resistance

CODE	DESCRIPTION	CAPACITY	TYPE APPROVAL
412 000 870	Type-approved wide mouth drum for solid transport Ø 320 x h 520 mm • cover Ø 250 mm	30 L	1H 2/X51/S/... 
412 000 871	Type-approved wide mouth drum for solid transport Ø 400 x h 620 mm • cover Ø 325 mm	60 L	1H 2/X100/S/... 
412 000 872	Type-approved wide mouth drum for solid transport Ø 496 x h 800 mm • cover Ø 395 mm	120 L	1H 2/X205/S/... 
412 000 873	Type-approved wide mouth drum for solid transport Ø 582 x h 985 mm • cover Ø 470 mm	200 L	1H 2/X 360/S/...

Food version available  **ON REQUEST**

### UN APPROVED WIDE MOUTH FOR LIQUID TRANSPORT



- Special containers for safe transportation of hazardous goods by truck, train, ship or plane in compliance with UN, RID/ADR OMI/IMDG AOCI RTMD regulations
- Fitted with a special cover with 4NU BCS 56x4 cap to facilitate filling operations

CODE	DESCRIPTION	CAPACITY	TYPE APPROVAL
412 000 874	UN approved wide mouth for liquid transport Ø 500 x h 800 mm • cover Ø 400 mm	120 L	1H 2/Y/...

Pictures indicated in this catalogue are representative and not binding for the supplier in terms of layout and colours. They may be subject to changes by the supplier without prior notice.

## TYPE-APPROVED IRON DRUMS FOR TRANSPORT (ADR)

Type-approved iron drums for dangerous goods transport, manufactured in compliance with UNI-EN regulations. Customer tailored drums upon request, depending on the product to be stored.



### TYPE-APPROVED DRUMS WITH SCREW CAP FOR TRANSPORTING LIQUIDS



- 6 and 15 L type-approved steel containers
- Packaging groups I, II, III for transport by truck, train, ship or plane
- Tri-sure screw caps
- Inside lacquering with epoxy resins for storing hydrocarbons, acids, alkali, foods and flammables

CODE	DESCRIPTION	CAPACITY	TYPE APPROVAL
412 000 875	Type-approved drum with 2" screw cap	6 L	1A1/X/350
412 000 876	Type-approved drum with 1 x 3/4" and 1 x 2" screw cap	15 L	1A1/X 1,2/250

### TYPE-APPROVED DRUM WITH REMOVABLE CLASP AND GASKET COVER FOR TRANSPORTING SOLIDS



CODE	DESCRIPTION	CAPACITY	TYPE APPROVAL
412 000 877	Type-approved drum with removable clasp and gasket cover • Ø 378 x h 590 mm	60 L	1A2/Y100/S
412 000 878	Drum with removable clasp and gasket cover Ø 470 x h 778 mm	110 L	1A2/Y143/S
412 000 879	Type-approved drum with removable clasp and gasket cover • Ø 595 x h 880 mm	220 L	1A2/Y217/S

### TYPE-APPROVED DRUMS WITH REMOVABLE CLASP AND GASKET COVER, LACQUERED INTERIOR



CODE	DESCRIPTION	CAPACITY	TYPE APPROVAL
412 000 880	Type-approved drum with removable clasp and gasket cover, lacquered interior • Ø 305 x h 434 mm	30 L	1A2/X 47/S/...
412 000 881	Type-approved drum with removable clasp and gasket cover, lacquered interior • Ø 380 x h 579 mm	60 L	1A2/Y1.4/100
412 000 882	Type-approved drum with removable clasp and gasket cover, lacquered interior • Ø 595 x h 880 mm	220 L	1A2/Y265/S

### TYPE-APPROVED DRUMS WITH REMOVABLE CLASP AND GASKET COVER, CAP AND SMALL CAP, FOR TRANSPORTING SOLIDS



CODE	DESCRIPTION	CAPACITY	TYPE APPROVAL
412 000 883	Type-approved drum with removable clasp and gasket cover, cap and small cap • Ø 378 x h 590 mm	60 L	1A2/Y/...
412 000 884	Type-approved drum with removable clasp and gasket cover, cap and small cap • Ø 595 x h 880 mm	220 L	1A2/Y/...

### UN-APPROVED STEEL DRUM WITH REMOVABLE CLASP AND GASKET COVER, CAP AND SMALL CAP, LACQUERED INTERIOR, FOR TRANSPORTING SOLIDS



CODE	DESCRIPTION	CAPACITY	TYPE APPROVAL
412 000 885	Type-approved drum with removable clasp and gasket cover, cap and small cap, lacquered interior Ø 595 x h 880 mm	220 L	1A2/Y/...

### TYPE-APPROVED DRUMS WITH TWO CAPS FOR TRANSPORTING LIQUIDS



CODE	DESCRIPTION	CAPACITY	TYPE APPROVAL
412 000 886	Type-approved drum with two caps • Ø 305 x h 465 mm	30 L	1A1/Z/...
412 000 887	Type-approved drum with two caps • Ø 378 x h 590 mm	60 L	1A1/Y/...
412 000 889	Type-approved drum with two caps • Ø 595 x h 880 mm	220 L	1A1/Y/...

### TYPE-APPROVED DRUMS WITH TWO CAPS, LACQUERED INTERIOR, FOR TRANSPORTING LIQUIDS



CODE	DESCRIPTION	CAPACITY	TYPE APPROVAL
412 000 890	Type-approved drum with two caps, lacquered interior • Ø 305 x h 465 mm	30 L	1A1/X/...
412 000 891	Type-approved drum with two caps, lacquered interior • Ø 380 x h 590 mm	60 L	1A1/X/...
412 000 888	Type-approved drum with two caps, lacquered interior • Ø 470 x h 800 mm	110 L	1A1/X/...
412 000 892	Type-approved drum with two caps, lacquered interior • Ø 595 x h 880 mm	220 L	1A1/X/...

## TYPE-APPROVED DRUMS WITH REMOVABLE CLASP AND GASKET COVER FOR LIQUID TRANSPORT



CODE	DESCRIPTION	CAPACITY	TYPE APPROVAL
412 002 917	Type-approved drum with removable clasp and gasket cover for liquid transport Ø 380 x h 620 mm	60 L	1A2/Y 1.4/100
412 002 918	Type-approved drum with removable clasp and gasket cover, cap and small cap for liquid transport Ø 595 x h 880 mm	220 L	1A2/Y 1.4/120

## TYPE-APPROVED DRUMS WITH REMOVABLE CLASP AND GASKET COVER, CAP AND SMALL CAP, LACQUERED INTERIOR, FOR LIQUID TRANSPORT



CODE	DESCRIPTION	CAPACITY	TYPE APPROVAL
412 002 920	Type-approved drum with removable clasp and gasket cover, cap and small cap for liquid transport Ø 595 x h 880 mm	220 L	1A2/Y 1.4/120
412 002 921	Type-approved drum with removable clasp and gasket cover, cap and small cap, and bottom drain for liquid transport Ø 595 x h 880 mm	220 L	1A2/Y 1.4/120

## TYPE-APPROVED BUCKETS WITH REMOVABLE CLASP AND GASKET CLOSURE



CODE	DESCRIPTION	CAPACITY	TYPE APPROVAL
412 002 836	Bucket with removable clasp and gasket cover • Ø 180 x h 242 mm	5 L	1A2/Y 1.6/100
412 002 837	Bucket with removable clasp and gasket cover • Ø 292 x h 230 mm	13 L	1A2/Y 1.4/150
412 002 838	Bucket with removable clasp and gasket cover • Ø 292 x h 365 mm	22 L	1A2/Y 1.3/115
412 002 839	Bucket with removable clasp and gasket cover • Ø 292 x h 450 mm	27 L	1A2/Y 1.6/150



### TYPE-APPROVED DRUM WITH REMOVABLE CLASP AND GASKET COVER, IN STAINLESS STEEL



CODE	DESCRIPTION	CAPACITY	TYPE APPROVAL
412 000 893	Type-approved drum with removable clasp and gasket cover, in stainless steel • Ø 595 x h 880 mm	220 L	1A2/X/...

### TYPE-APPROVED DRUM WITH REMOVABLE CLASP AND GASKET COVER, CAP AND SMALL CAP, IN STAINLESS STEEL



CODE	DESCRIPTION	CAPACITY	TYPE APPROVAL
412 000 894	Type-approved drum with removable clasp and gasket cover, cap and small cap, in stainless steel Ø 595 x h 880 mm	220 L	1A2/X/...

### TYPE-APPROVED DRUM, TWO CAPS, IN STAINLESS STEEL



CODE	DESCRIPTION	CAPACITY	TYPE APPROVAL
412 000 895	Type-approved drum, two caps, in stainless steel Ø 595 x h 880 mm	220 L	1A1/X/...

### TYPE-APPROVED DRUM WITH REMOVABLE CLASP AND GASKET COVER, CAP AND SMALL CAP, GALVANISED



CODE	DESCRIPTION	CAPACITY	TYPE APPROVAL
412 000 896	Type-approved drum with removable clasp and gasket cover, cap and small cap, galvanised Ø 595 x h 880 mm	220 L	1A2/Y1,4/120

\* Fitted with lower 2" cap for positioning of taps

## ACCESSORIES FOR DAMAGED DRUMS

Set of accessories designed for damaged or buckled drums. Allow effective intervention to contain accidental spills and leakages (When transporting products which fall under ADR (DGT) regulations, the overpacks can only be used to transport damaged drums containing solid products).

### "MATRIOSKA" POLYETHYLENE (PE) SAFETY OVERPACK FOR DRUMS ADR APPROVED (ADR/RID)



- Polyethylene (PE) safety container for damaged drums storage and safekeeping
- Holds drums up to 200 L

CODE	DESCRIPTION	CAPACITY	TYPE APPROVAL
412 000 897	Polyethylene (PE) overpack for drums approved for ADR • Ø 750 x h 1050 mm	335 L	1H 2/Y320/S

### "MATRIOSKA" STEEL SAFETY OVERPACK FOR DRUMS ADR APPROVED (ADR)



- Painted steel safety container for damaged drums storage and safekeeping
- Holds drums up to 200 L

CODE	DESCRIPTION	CAPACITY	TYPE APPROVAL
412 000 898	Steel overpack for drums approved for ADR • Ø 630 x h 930 mm	280 L	1A2/X351/S

### TECHNOPOLYMER DRUM BANDAGE



- Easy to use in emergency situations
- Suitable for iron and plastic drums
- Made from precious polymers
- Hard-wearing and flexible, sticks perfectly to the damaged surface
- Resistant to hydrocarbons and the majority of aggressive liquids
- Reusable after washing

CODE	DESCRIPTION
412 000 900	Technopolymer drum bandage • 340 x h 180 mm

## TECHNOPOLYMER CONICAL CAPS FOR LEAKAGE BLOCKING



- Conical caps for sealing drum, containers, pipes etc.
- Made from rubber technopolymer
- With handling hook
- Reusable after washing

CODE	DESCRIPTION
412 000 901	Technopolymer conical cap for leakage blocking • Ø from 40 to 65 mm
412 000 902	Technopolymer conical cap for leakage blocking • Ø from 55 to 85 mm
412 000 903	Technopolymer conical cap for leakage blocking • Ø from 90 to 115 mm
412 000 904	Set of 3 conical caps with 3 different sizes

## DRUM PROTECTION ACCESSORIES

Set of drum covers designed to protect drums from atmospheric agents during outdoor storage.

### POLYETHYLENE (PE) COVERS



- Polyethylene (PE) cover for 220 L steel drums
- Ideal for protecting drums outdoors

CODE	DESCRIPTION
412 000 905	Polyethylene (PE) drum cover • Ø 600 x h 90 mm • yellow
412 000 906	Polyethylene (PE) drum cover • Ø 600 x h 90 mm • green
412 000 907	Polyethylene (PE) drum cover • Ø 600 x h 90 mm • red
412 000 908	Polyethylene (PE) drum cover • Ø 600 x h 90 mm • blue
412 000 909	Polyethylene (PE) drum cover • Ø 600 x h 90 mm • black

## DRUM FILLING ACCESSORIES

Set of funnels used for different liquid pouring and filling operations. Safe systems to avoid accidental spills during operation.

### PAINTED STEEL FUNNELS WITH SELF-CLOSING COVER AND FLAME ARRESTOR



- Safety funnel for drums, ensures perfect safety when pouring liquids into large drums
- With brass flame arrestor and hinged self-closing cover with fuse that triggers the automatic safety locker in temperatures of over 74°C
- Lockable
- Made from galvanized steel (1 mm thick) coated in epoxy powder paint
- FM certification

CODE	DESCRIPTION	STEM LENGTH
412 000 911	Painted steel funnel with self-closing cover and flame arrestor • Ø 273 x h 254 mm	152 mm
412 000 912	Painted steel funnel with self-closing cover and flame arrestor • Ø 273 x h 254 mm	813 mm

### GALVANIZED STEEL FUNNEL WITH COVER



412 000 913

CODE	DESCRIPTION	AIR
412 000 913	Galvanised steel funnel with cover • Ø 300 x h 130 mm	2"

CODE	DESCRIPTION
412 002 376	2" stainless steel funnel (Ø 140 mm)
412 002 377	2" stainless steel funnel (Ø 190 mm)



412 002 376



412 002 377

### POLYETHYLENE (PE) FUNNEL



- Easy to use in emergency situations
- Suitable for iron and plastic drums
- Made from high-quality polymers
- Hard-wearing and flexible, sticks perfectly to the damaged surface
- Resistant to hydrocarbons and the majority of aggressive liquids
- Reusable after washing
- For 220 litre drums

CODE	DESCRIPTION	DISCHARGE
412 000 914	Polyethylene (PE) funnel • Ø 550 x h 190 mm	Ø 40 mm
412 000 915	Removable cover for polyethylene (PE) funnel	



## DRUM HEATING ACCESSORIES

Heaters are perfect for drums whose content should be kept at constant temperature, at a certain viscosity or to prevent it from freezing.

The liquid contents inside the drum can be heated via its base, its body or both, thanks to the use of straps, bases, or insulating or heated jackets. All heaters are suitable for heating: water, oil and diesel, resin, petroleum jelly, wax, fats, butter.

### FLEXIBLE BAND DRUM-HEATER 0-120°C



- Silicone rubber drum-heater band
- Supply: electricity
- Power supply: V230
- For 200 litre drums

CODE	DESCRIPTION	POWER
412 000 917	Flexible band drum-heater 0°-120° C • 1700 x h 115 mm	1000 W

### DRUM-HEATING BASE 0°-120°C AND 50°-300°C



- Fibreglass encapsulated silicone heating element
- High density rockwool insulation (50 mm)
- For drums up to 200 litres

CODE	DESCRIPTION	POWER
412 002 380	Drum-heating base 0°-120° C • 550 x h 105 mm With digital display	900 W
412 004 918	Drum-heating base 50°-300° C • 550 x h 105 mm	1800 W <b>new</b>

### DRUM INSULATING JACKET



- In polyurethane nylon
- Water-resistant
- Flameproof
- For 200 litre drums

CODE	DESCRIPTION
412 002 842	Insulation jacket for drums • 1990 x h 900 mm

## DRUM HEATING JACKET 0°- 40°C AND 0°- 90°C



- Made of polyester
- Adjustable straps for quick opening
- 3 m power cable, protection IP40
- Thermostat 0-40°C or 0-90°C

CODE	DESCRIPTION	POWER
412 004 885	Drum heating jacket 0°- 40° C 1990 x h 800 mm • for 200 L drums	1200 W <b>new</b>
412 004 886	Drum heating jacket 0°- 40° C 1330 x 460 mm • for 50/60 L drums	1200 W <b>new</b>
412 002 840	Drum heating jacket 0°- 90° C 1990 x h 800 mm • for 200 L drums	1200 W
412 002 841	Drum heating jacket 0°- 90° C 1330 x h 460 mm • for 50/60 L drums	300 W

## DRUM HEATING JACKET



412 004 884

### Food and pharmaceutical version

- Silicone/fibreglass coating
- Fibreglass cover.
- Silicone insulated coil resistor element.
- Adjustable fabric straps, easy to unhook.
- Standard size: 200 litres
- 3m power cord
- 0-120°C thermostat
- Protection IP54

Optional: cover cap

CODE	DESCRIPTION	POWER
412 004 884	Drum heating jacket for food and pharmaceutical products 0°-120° C • 1990 x h 800 mm for 200 L drums	1200 W  <b>new</b>



412 002 381

### Standard version

- Made of coated fibreglass and silicone
- With three-belt closure
- Quick opening

CODE	DESCRIPTION	POWER
412 002 381	Drum heating jacket 0°-200° C • 1990 x h 800 mm • for 200 L drums	1200 W



412 001 955

### ATEX version per directive 94/9/EC:

- Made of elastomer and fibreglass
- Silicone coated
- Suitable for gentle heating or to prevent freezing during the winter

CODE	DESCRIPTION	POWER
412 001 955	Drum-heater jacket • 1990 x h 800 mm ATEX certified	1050 W

## DRUM OPENING EQUIPMENT

Tools made to facilitate manual removal of metal drum covers or bungs.

### DRUM DEHEADER WRENCH



- Non-sparking bronze-covered steel construction
- Multi-purpose wrench head suitable for most drum types
- User friendly design with rounded teeth

CODE	DESCRIPTION	WEIGHT
412 000 918	Drum opening wrench for 2" and 3/4" bungs	750 g



- Non-sparking bronze-covered steel construction
- Multi-purpose wrench head suitable for most drum types
- Additional 1 1/4" socket for tightening drum caps
- User friendly design with rounded teeth

CODE	DESCRIPTION	WEIGHT
412 000 919	Drum opening wrench for 2" and 3/4" bungs	800 g



- Non-sparking bronze-covered steel construction
- Multi-purpose wrench head suitable for all drum types
- User friendly design with rounded teeth

CODE	DESCRIPTION	WEIGHT
412 000 920	Drum opening wrench for 2" and 3/4" bungs	1.4 Kg



- Non-sparking bronze alloy construction
- Multi-purpose wrench head suitable for most drum covers
- 460 mm length to increase opening force

CODE	DESCRIPTION	WEIGHT
412 000 921	Drum opening wrench for 2" and 3/4" bungs	1.8 Kg



- Galvanized iron construction
- Suitable for plastic and metal drums
- Non-slip rubber grip

CODE	DESCRIPTION	WEIGHT
412 000 922	Drum opening wrench for 2" and 3/4" bungs	750 g



- Non-sparking brass construction
- Suitable for plastic and metal drums
- Non-slip rubber grip

CODE	DESCRIPTION	WEIGHT
412 000 923	Drum opening wrench for 2" and 3/4" bungs	600 g

## DRUM DEHEADING TOOLS



- Drum deheading tool for metal drum covers
- Steel construction
- Adjustable to suit material hardness and drum rims

CODE	DESCRIPTION	WEIGHT
412 000 924	Drum deheading tool (Z)	3.5 Kg
601 000 001	Spare steel blade (Z)	-



- Non-sparking deheading tool for metal drum covers
- Bronze and aluminium construction
- Adjustable to suit material hardness and drum rims

CODE	DESCRIPTION	WEIGHT
412 000 926	Drum deheading tool (B)	3.5 Kg
601 000 002	Spare steel blade (B)	-



## DRUM GAUGE LEVEL INDICATOR



Gauge level indicator with float for drums that can be used in 2" threaded openings. Litre calibration.

CODE	DESCRIPTION
412 004 591	Drum gauge level indicator



### DRUM TAPS

Accessories useful for safely pouring off the liquids contained in drums, these drum taps are designed according to the type of fluid, differing in the material used, technical characteristics and closing systems.

#### AISI 316 STAINLESS STEEL TAPS



- Ball tap for drum pouring, 90° elbow
- With padlock
- All components in AISI 316 stainless steel

CODE	DESCRIPTION
412 000 939	AISI 316 stainless steel tap, 3/4"
412 000 940	AISI 316 stainless steel tap, 2"

#### ACID-PROOF PVC TAPS WITH VITON GASKETS



- Acid-proof PVC ball tap with Viton gaskets for drum pouring
- With 90° elbow and hose carrier
- Detachable flanges

CODE	DESCRIPTION
412 000 941	Acid-proof 3/4" PVC tap
412 000 942	Acid-proof 2" PVC tap

#### STAINLESS STEEL TAP WITH AUTOMATIC SAFETY LOCKER



- Stainless steel body, heavy duty
- Flame arrester, rotating body, Teflon (PTFE) gaskets
- Lockable
- Adjustable pouring

CODE	DESCRIPTION
412 000 943	3/4" stainless-steel tap with automatic safety locker

#### ALUMINIUM ALLOY TAPS WITH AUTOMATIC SAFETY LOCKER



- Aluminium alloy body
- Lockable
- Nylon gaskets
- Automatic safety locker

CODE	DESCRIPTION
412 000 944	3/4" aluminium alloy tap with automatic safety locker
412 000 945	3/4" aluminium alloy tap with automatic safety locker and flame arrester

#### BRASS TAPS WITH AUTOMATIC SAFETY LOCKER



- Brass body, heavy duty
- Lockable
- With flame arrester and Teflon (PTFE) gaskets
- Automatic safety locker

CODE	DESCRIPTION
412 000 946	3/4" brass tap with automatic safety locker
412 000 947	3/4" brass tap with automatic safety locker and rotating spout (360°)

Pictures indicated in this catalogue are representative and not binding for the supplier in terms of layout and colours. They may be subject to changes by the supplier without prior notice.

## CAST IRON TAPS



- Cast iron body
- Smooth operation and easy flow control
- Lockable
- Ideal for dense liquids

CODE	DESCRIPTION
412 000 948	3/4" cast iron tap
412 000 949	2" cast iron tap

## WIDE MOUTH BRASS TAPS



- Brass body and Teflon (PTFE) gaskets
- Heavy duty for dispensing SAE 30 viscous liquids, glues, paints
- Automatic safety locker

CODE	DESCRIPTION
412 000 950	Wide mouth brass tap 2"

## POLYETHYLENE (PE) TAP WITHOUT GASKETS



- 100% polyethylene (PE)
- Without gaskets
- Suitable for acids

CODE	DESCRIPTION
412 000 951	3/4" polyethylene (PE) tap without gaskets

## WIDE MOUTH POLYETHYLENE (PE) TAP



- Polyethylene (PE) body with EPT gaskets
- Empties a 210 L drum in appr. 3 min

CODE	DESCRIPTION
412 000 952	Wide mouth polyethylene (PE) tap 2"

## DRUM VENTS



412 000 953

412 000 954

Automatic aperture ideal for automatically discharging excess evaporation gas pressure. Manual operation is also possible.

- Vented filler cap and built-in flame arrestor
- All brass construction

CODE	DESCRIPTION
412 000 953	2" drum vent with gasket

- Brass vent with gaskets

CODE	DESCRIPTION
412 000 954	2" drum vent for use with 3/4" tap

## MANUALLY OPERATED ROTARY PUMPS FOR HYDROCARBONS

Wide range of rotary pumps for hydrocarbon dispensing. Easy to install, for quick drum emptying. With suction hose for drum connection.

### SPECIFIC PUMPS FOR PETROL, DIESEL, PARAFFIN AND LIGHT OILS



- Twin-impeller rotary action
- Aluminium alloy construction
- 2" adaptor
- 1065 mm suction pipe (suits 914 mm deep drums)
- 32 mm diameter outlet pipe
- 1250 mm delivery hose
- Inlet filter

CODE	DESCRIPTION	MAX. FLOW RATE
412 000 955	Twin-impeller rotary pump in aluminium	100 L/min

- Reversible rotary action
- Aluminium alloy construction
- 2" adaptor
- 1065 mm suction pipe (suits 914 mm deep drums)
- 32 mm diameter outlet pipe
- 2000 mm delivery hose
- Inlet and outlet filter

CODE	DESCRIPTION	MAX. FLOW RATE
412 000 956	Reversible rotary pump in aluminium	50 L/min

### PUMPS SUITABLE FOR ALL GRADES OF OIL



- Rotary action
- Cast iron construction
- 2" adaptor
- 19 mm diameter outlet pipe
- 1015 mm suction pipe (suits 914 mm deep drums)

CODE	DESCRIPTION	MAX. FLOW RATE
412 000 957	Cast iron rotary pump	16 L/min

- Rotary action
- Cast iron construction
- 2" adaptor
- 25 mm diameter outlet pipe
- 1015 mm suction pipe (suits 914 mm deep drums)

CODE	DESCRIPTION	MAX. FLOW RATE
412 000 958	Cast iron rotary pump	25 L/min

#### INSULATE AGAINST STATIC BUILD-UP

Static electricity may be generated when using rotary pumps. In order to prevent sparking caused by static build-up, when pumping flammable liquids a bonding wire must be used. i.e. the container must be grounded to earth by means of a conductive earthing lead fastened between the container and a suitable grounded earth point.

## SPECIFIC PUMP FOR OIL AND DIESEL



- Rotary hand pump in carbon steel with aluminium components
- Ideal for pouring and topping up oil and diesel from drums
- With flexible hose
- Delivery per stroke: 0.32 L
- Product outlet dia.: M 3/4"
- Pumping distance: 1000 mm
- Designed for 208 litre drums
- Weight: 3.8 Kg

CODE	DESCRIPTION	MAX. FLOW RATE
412 000 961	Rotary hand pump in carbon steel	23 L/min

## MANUAL LEVER PUMPS FOR HYDROCARBONS

Manually operated devices made with technical characteristics and materials to optimise pumping of liquids such as oils and antifreeze.

### SPECIFIC PUMPS FOR OIL AND ANTIFREEZE



412 000 962

- Single acting positive-displacement hand pumps in carbon steel with aluminium components and Viton gaskets
- Delivery per stroke: 0.25 L
- Product outlet coupling: M 3/4" BSP
- Pumping distance: 1000 mm

CODE	DESCRIPTION	MAX. FLOW RATE
412 000 962	Volumetric hand pump in carbon steel	12 L/min



412 000 963

- Double acting positive-displacement hand pumps in carbon steel with aluminium components and Viton gaskets
- Delivery per stroke: 0.48 l
- Product outlet coupling: M 3/4" BSP
- Pumping distance: 1000 mm

CODE	DESCRIPTION	MAX. FLOW RATE
412 000 963	Volumetric hand pump in carbon steel	24 L/min



## MANUALLY OPERATED ROTARY PUMPS FOR CHEMICALS

Rotary pumps easy to be used and made with high quality material to grant a higher chemical resistance. Available in polypropylene (PP) or Ryton depending on the application.

### SUITABLE FOR CHEMICALS AND SOLVENTS



- Twin-impeller rotary action
- RYTON and stainless steel construction
- 2" adaptor
- 1065 mm suction pipe (suits 914 mm deep drums)
- 32 mm diameter outlet pipe
- 1250 mm delivery hose
- Inlet filter

CODE	DESCRIPTION	MAX. FLOW RATE
412 000 967	Twin-impeller rotary pump in Ryton and stainless steel	100 L/min

### SPECIFIC PUMP FOR WATER-BASED ACID, ALKALI AND SALINE SOLUTIONS, ORGANIC SOLVENTS AND PETROLEUM PRODUCTS



- Reversible rotary action
- Yellow polypropylene (PP) construction
- Phenolic vanes
- Viton gaskets
- Polyethylene (PE) flange gasket
- 2" adaptor
- Three x 390 mm section tube with threaded connectors (1200 mm total length)
- 3/4" threaded outlet pipe

CODE	DESCRIPTION	MAX. FLOW RATE
412 000 968	Reversible rotary pump in PP	35 L/min
412 000 969		50 L/min

### PUMPS FOR HIGHLY CORROSIVE CHEMICALS INCLUDING CHLORINATED SOLVENTS, AROMATIC AND ALIPHATIC HYDROCARBONS



- Reversible rotary action
- Black Ryton vanes
- Viton gaskets
- Teflon (PTFE) flange gasket
- 2" adaptor
- Three x 390 mm section tube with threaded connectors (1200 mm total length)
- 3/4" threaded outlet pipe
- NOT SUITABLE FOR: ketones, esters or concentrated oxidising agents

CODE	DESCRIPTION	MAX. FLOW RATE
412 000 970	Reversible rotary pump in Ryton	35 L/min
412 000 971		50 L/min

#### INSULATE AGAINST STATIC BUILD-UP

Static electricity may be generated when using rotary pumps. In order to prevent sparking caused by static build-up, when pumping flammable liquids a bonding wire must be used. i.e. the container must be grounded to earth by means of a conductive earthing lead fastened between the container and a suitable grounded earth point.

## SPECIFIC PUMP FOR ACIDS

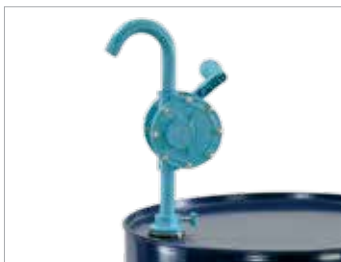

- Reversible rotary action
- PVC construction with Teflon (PTFE) vanes
- Teflon (PTFE) seals and stainless-steel components.
- 2" adaptor
- 25 mm inlet port
- 3-piece suction pipe with 2" adaptor

CODE	DESCRIPTION	MAX. FLOW RATE
412 000 972	Reversible action rotary pump in PVC and stainless steel	27 L/min

## SPECIFIC PUMP FOR CHEMICALS, SOLVENTS, ACIDS, ACETONES, ALCOHOL, MINERAL OILS, LYE SOLUTIONS



- AISI 304 Stainless Steel and Teflon (PTFE) construction
- 350 c per turn
- Delivery hose: dia 25 mm
- 3-piece suction pipe (330 mm each)
- 2" adaptor

CODE	DESCRIPTION	MAX. FLOW RATE
412 000 975	Rotary pump in Teflon (PTFE) and AISI 304 stainless steel	25 L/min

Pictures indicated in this catalogue are representative and not binding for the supplier in terms of layout and colours. They may be subject to changes by the supplier without prior notice.



## MANUAL PUMPS FOR CHEMICALS

Lightweight and easy to use, manufactured from the highest quality materials to ensure excellent chemical resistance.

### SPECIFIC PUMP FOR LIGHT OILS, PARAFFIN, DIESEL, ALCOHOL, WATER, WATER-BASED CHEMICALS, LIGHT SOLVENTS, ANTIFREEZE



- 3-piece telescopic suction pipe
- Extends to 914mm
- Polypropylene (PP) pump body and components
- Galvanized steel piston rod
- Viton gaskets
- Blue pump body

CODE	DESCRIPTION	MAX. FLOW RATE
412 000 976	Lever pump in PP	30 L/min

### SPECIFIC PUMP FOR LIGHT OILS, PARAFFIN, DIESEL, ALCOHOL, WATER, WATER-BASED CHEMICALS, LIGHT SOLVENTS, ANTIFREEZE, ACID AND ALKALI SOLUTIONS



- 3-piece telescopic suction pipe
- Extends to 914mm
- Polypropylene (PP) and fibre mix body and components
- Stainless steel piston rod
- Viton gaskets
- Yellow pump body

CODE	DESCRIPTION	MAX. FLOW RATE
412 000 977	Lever pump in PP and fibre mix	30 L/min

### SPECIFIC PUMP FOR EXTREMELY AGGRESSIVE LIQUID CHEMICALS, SOLVENTS, HIGHLY CONCENTRATED ACIDS AND ALKALIS EVEN IN 100% SOLUTIONS

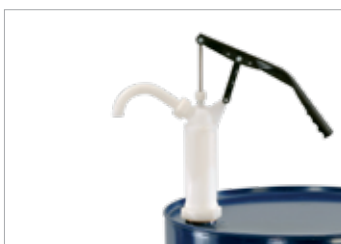

- Teflon (PTFE) body
- 316 Stainless steel piston rod
- Teflon (PTFE) gaskets

CODE	DESCRIPTION	MAX. FLOW RATE
412 000 980	Alternative pump in Teflon (PTFE) and stainless steel with lever	30 L/min

## SPECIFIC PUMP FOR WATER, DETERGENTS, SEAWATER, NON-CORROSIVE LIQUIDS, CRUDE OIL, DIESEL, KEROSENE AND LIGHT OILS



- Gasket-free design
- PVC, polyethylene (PE), steel and non-toxic rubber construction
- 2" adaptor
- 38 mm outlet
- PVC discharge hose (45 x 1000mm)

CODE	DESCRIPTION	MAX. FLOW RATE
412 000 983	PVC lift pump	50 L/min

## SPECIFIC PUMPS FOR LIGHT OILS, PARAFFIN, DIESEL, ALCOHOL, WATER, WATER-BASED CHEMICALS, LIGHT SOLVENTS, ANTIFREEZE, HIGHLY CORROSIVE ACIDS AND ALKALIS, NITRIC ACID ETC.



- 3-piece telescopic suction pipe
- Extends to 914mm
- Stainless steel piston rod for code 412 000 978
- Teflon (PTFE) piston rod for code 412 000 979
- Viton gaskets
- Black pump body

CODE	DESCRIPTION	MAX. FLOW RATE
412 000 978	Lever pump in Ryton PP	30 L/min
412 000 979	Lever pump in Teflon (PTFE) /polypropylene (PP)	30 L/min

## JERRYCAN PUMP



Lightweight, versatile pump, easy to clean and transfer from one container to another. Made of polypropylene, polyethylene and ABS (acrylonitrile butadiene styrene).

The pump's lifting action ensures that the fluid is delivered uphill, thus allowing complete control of the liquid flow rate.

The pressure-adjustable bevel-shaped collar fits all types of containers such as steel, plastic or cardboard jerrycans, drums and cans.

It allows the containers to be emptied without spilling and keeps the fluid contained during dispensing. The gasketless construction prevents wear and subsequent need for replacement.

Suitable for water, paints, degreasers, diesel, petrol, kerosene, light oils, solvents.

CODE	DESCRIPTION	MAX. FLOW RATE
412 004 582	Manual jerrycan pump	approx. 10 L/min



## ELECTRIC AND PNEUMATIC PUMPS FOR HAZARDOUS LIQUIDS AND CORROSIVE FLUIDS

Portable drum and IBC transfer pumps. Particularly suited for pumping corrosive liquids. Available with electric or pneumatic motor. With open impeller for continuous pumping of clean corrosive liquids.

### FEATURES

- PP, PVDF and AISI 316 construction
- Inexpensive and portable
- Suitable for corrosive liquids
- Available with electric or pneumatic motor
- Adjustable flow rate (pneumatic version)
- No mechanical seals

### PNEUMATIC PUMPS WITH POLYPROPYLENE (PP) BODY



#### BODY FEATURES

- Suction hose: Ø 42 mm
- Hose clamp: Ø 25 mm
- Max. temperature: 60°C
- Suct. hose material: PP
- Shaft material: HASTELLOY
- Bushing material: PTFE

- Rotor material: ECTFE
- Intake port material: PP
- Internal parts: PP + PTFE

#### MOTOR FEATURES

- Motor power: 0.33 HP at 7 bar
- Capacity: 80 L/min
- Viscosity: 600 cps

CODE	DESCRIPTION	SUCTION HEIGHT
412 000 984	Pneumatic pump with polypropylene (PP) body	900 mm (for drums)
412 000 985	Pneumatic pump with polypropylene (PP) body	1200 mm (for IBCs)

### PNEUMATIC PUMPS WITH PVDF BODY



#### BODY FEATURES

- Suction hose: Ø 40 mm
- Hose clamp: Ø 25 mm
- Max. temperature: 95°C
- Suct. hose material: PVDF
- Shaft material: HASTELLOY
- Bushing material: PTFE

- Rotor material: ECTFE
- Intake port material: ECTFE
- Internal parts: PVDF + PTFE

#### MOTOR FEATURES

- Motor power: 0.33 HP at 7 bar
- Capacity: 80 L/min
- Viscosity: 600 cps

CODE	DESCRIPTION	SUCTION HEIGHT
412 000 986	Pneumatic pump with PVDF body	900 mm (for drums)
412 000 987	Pneumatic pump with PVDF body	1200 mm (for IBCs)

### PNEUMATIC PUMPS WITH AISI 316 BODY



#### BODY FEATURES

- Suction hose: Ø 42.5 mm
- Hose clamp: Ø 25 mm
- Max. temperature: 95°C
- Suct. hose material: AISI 316
- Shaft material: AISI 316
- Bushing material: PTFE

- Rotor material: ECTFE
- Intake port material: ECTFE
- Internal parts: PTFE+PPS-V

#### MOTOR FEATURES

- Motor power: 0.33 HP at 7 bar
- Capacity: 80 L/min
- Viscosity: 600 cps

CODE	DESCRIPTION	SUCTION HEIGHT
412 000 988	Pneumatic pump with AISI 316 body	900 mm (for drums)
412 000 989	Pneumatic pump with AISI 316 body	1200 mm (for IBCs)

# PNEUMATIC DIAPHRAGM PUMPS FOR CHEMICALS

Diaphragm pumps have exceptional performance, power and strength, making them ideal for pumping liquids with very high apparent viscosity up to 40,000 cps (at 20°C), depending on the chosen model.

## FEATURES:

- Stall-prevention pneumatic system for safe pump running without the need for lubricated air
- Dry self-priming even with high suction heights, fine speed adjustment with no pressure loss, ability to run dry: an unprecedentedly versatile pump
- The wide range of composition materials also ensure the best possible chemical compatibility with the liquid and/or working environment, without neglecting the temperature range
- They are specifically designed for demanding applications with high humidity or in potentially explosive atmospheres (ATEX certification)
- Maximum head: 70 m
- Max. air supply pressure: 7 bars



PP



PVDF



Al



AISI 316

CODE	DESCRIPTION	COUPLINGS SUCTION/DELIVERY	AIR COUPLING	SUCTION CAPACITY DRY MAX	CAPACITY MAX
412 002 382	Pneumatic diaphragm pump in PP	G 1/2" f or DN 15	G 3/8" f	5 m	50 L/min
412 002 383	Pneumatic diaphragm pump in PVDF				
412 002 384	Pneumatic diaphragm pump in Al				
412 002 385	Pneumatic diaphragm pump in AISI 316				

CODE	DESCRIPTION	COUPLINGS SUCTION/DELIVERY	AIR COUPLING	SUCTION CAPACITY DRY MAX	CAPACITY MAX
412 002 386	Pneumatic diaphragm pump in PP	G 1" f or DN 25	G 3/8" f	6 m	100 L/min
412 002 387	Pneumatic diaphragm pump in PVDF				
412 002 388	Pneumatic diaphragm pump in Al				
412 002 389	Pneumatic diaphragm pump in AISI 316				

CODE	DESCRIPTION	COUPLINGS SUCTION/DELIVERY	AIR COUPLING	SUCTION CAPACITY DRY MAX	CAPACITY MAX
412 002 390	Pneumatic diaphragm pump in PP	G 1" 1/4 f or DN 32	G 1/2" f	5 m	220 L/min
412 002 391	Pneumatic diaphragm pump in PVDF				
412 002 392	Pneumatic diaphragm pump in Al				
412 002 393	Pneumatic diaphragm pump in AISI 316				

## PNEUMATIC DIAPHRAGM PUMPS FOR LIQUID FOODSTUFFS



Diaphragm pumps have exceptional performance, power and strength, making them ideal for pumping liquids with very high apparent viscosity up to 50000 cps (at 20°C), even those containing suspended solids.

### FEATURES:

- Stall-prevention pneumatic system for safe pump running without the need for lubricated air
- Dry self-priming even with high suction heights, fine speed adjustment with no pressure loss, ability to run dry with no damage: an unprecedentedly versatile pump
- They are specifically designed for demanding applications with high humidity or in potentially explosive atmospheres (ATEX certification)
- Maximum head: 70 m
- Max. air supply pressure: 7 bars

CODE	DESCRIPTION	COUPLINGS SUCTION/DELIVERY	AIR COUPLING	SUCTION CAPACITY DRY MAX	CAPACITY MAX
412 002 394	Pneumatic diaphragm pump for food liquids in AISI 316	G 1/2" f	G 3/8" f	4 m	50 L/min
412 002 395	Pneumatic diaphragm pump for food liquids in AISI 316	G 1" f	G 3/8" f	4 m	100 L/min
412 002 396	Pneumatic diaphragm pump for food liquids in AISI 316	G 1" 1/4 f	G 1/2" f	4 m	220 L/min

## GEAR PUMPS



Gear pumps with inner profile designed for valid, modern solutions for different lubricant oil pumping needs.

### FEATURES:

- Continuous operation
- Noise less than 70 dB
- Viscosity up to 2000 cSt
- Power supply: 230 V/50 Hz
- Power: 550 W for code 412 002 397 and 750 W for code 412 002 025
- Delivery pipe coupling: 1" BSP
- Speed (rpm): 1450
- Pressure: 12 bars

CODE	DESCRIPTION	CAPACITY
412 002 397	Gear pump	9 L/min
412 002 025	Gear pump	14 L/min

## VANE PUMPS



Electric vane pump for medium viscosity oil transfer, high flow rate.

### FEATURES:

- Continuous operation
- Noise less than 70 dB
- Upper viscosity, up to 500 cSt
- Power supply: 230 V/50 Hz for model 412 002 399 and 230 V/50-60 for code 412 002 400
- Power: 750 W for code 412 002 399 and 1600 W for code 412 002 400
- Delivery pipe coupling: 1" BSP
- Speed (rpm): 1450 for code 412 002 399 and 1450-1700 for code 412 002 400
- Pressure: 6 bars

CODE	DESCRIPTION	CAPACITY
412 002 399	Vane pump	25 L/min
412 002 400	Vane pump	50 L/min

## TRANSFER UNITS

Solutions developed to facilitate transfer of liquids contained in a tank or other storage system. All transfer units are equipped with a pump and a system of hoses necessary to suck up and deliver the liquid.

### TRANSFER UNIT KIT



Transfer unit designed for easy drum connection with 2" snap-on coupling. Units available in two different versions, supplied with telescopic suction pipe for direct drum connection and gun. The system has been designed and manufactured for the distribution of diesel oil.



#### LITRE COUNTER KIT COMPOSITION:

- Electric pump with on/off switch
- Telescopic suction pipe
- Delivery pipe (4 metres)
- Hand gun
- Gun holder
- Couplings and fittings
- Litre counter
- Delivery pipe: 1" BSP

#### STANDARD KIT COMPOSITION:

- Electric pump with on/off switch
- Telescopic suction pipe
- Delivery pipe (4 metres)
- Hand gun
- Gun holder
- Couplings and fittings
- Delivery pipe: 1" BSP

CODE	DESCRIPTION	CAPACITY
412 002 404	Base version kit • 12 Volt	80 L/min
412 002 405	Base version kit • 24 Volt	80 L/min
412 002 406	Kit with litre counter • 12 Volt	80 L/min
412 002 407	Kit with litre counter • 24 Volt	80 L/min



### PORTABLE KITS WITH SELF-PRIMING TRANSFER PUMP



Environmental conditions may potentially compromise earth moving machinery and equipment refuelling operations. This kit is designed for rapid, safe refuelling in any condition. Only compatible with diesel fuel.

The kit includes:

- Self-priming transfer pump
- Delivery hose (4 metres)
- Suction hose with bottom valve
- Hand gun
- Dimensions: 400 x 300 x h 420 mm

CODE	DESCRIPTION	CAPACITY
412 002 408	Portable kit • 12 V • 260 W	45 L/min
412 002 409	Portable kit • 24 V • 310 W	45 L/min

### MOBILE TRANSFER UNIT WITH SPILL SUMP



Ideal for oil dispensing needs requiring the drum to be moved around the workshop.

The mobile transfer unit is composed of:

- Transfer unit with trolley-mounted containment sump
- Self-priming gear pump
- Motor switches on/off automatically when the dispensing gun is opened/closed
- Oil viscosity from 50 to 2000 cSt
- Self-priming pump with asynchronous closed self-ventilating AC motor (IP55) 230 V
- Bottom valve with filter
- 1/2" 4-metre delivery pipe Gas
- Litre counter gun with possibility for preselection dispensing
- When the preselected quantity has been dispensed the valve closes automatically to stop the flow
- Can be used with oil
- Power: 0.75 kW
- Pressure: 70 bars

CODE	DESCRIPTION	CAPACITY
412 001 043	Mobile transfer unit with spill sump	1 ÷ 30 L/min

## ELECTRIC LABORATORY PUMPS

Electric devices made with technical characteristics and materials to optimise transfer of hydrocarbons or highly corrosive liquid chemicals, ideal for transfer and dosing of small quantities of liquids.

### PP PUMPS FOR ACIDIC AND BASIC PRODUCTS



- Ideal for transferring small quantities from drums or small containers
- Materials: Body (PP/PVDF) - Impeller (PP) - Shaft (Hastelloy C)
- Absorption of installed power: 200 W
- Viscosity: 300 mPas
- Capacity: 75 L/min
- Temperature: 50°C max.
- Head: 7 water column meters
- Set complete with pump, motor, PP dispenser, two hose clamps
- 3/4" PVC hose, length 1.5 m, wall mount bracket



CODE	DESCRIPTION	SUCTION HEIGHT
412 001 006	Electric laboratory pump in PP for acidic and basic products	500 mm
412 001 007		700 mm
412 001 008		1000 mm

CODE	DESCRIPTION	AIR
412 001 009	Litre counter for polypropylene (PP) pump	G 1"

### STAINLESS-STEEL PUMPS FOR LUBRICANTS AND SOLVENTS



- Ideal for transferring small quantities from drums or small containers
- Materials: Body (AISI 316) - Impeller (AISI 316) - Shaft (AISI 316)
- Absorption of installed power: 200 W
- Viscosity: 300 mPas
- Capacity: 68 lt/min
- Temperature: 90°C max.
- Head: 6.5 water column meters
- Set complete with pump, motor, PP dispenser, two hose clamps
- 3/4" PVC hose, length 1.5 m, wall mount bracket



CODE	DESCRIPTION	SUCTION HEIGHT
412 001 010	Stainless-steel electric laboratory pump for lubricants and solvents	500 mm
412 001 011		700 mm
412 001 012		1000 mm

CODE	DESCRIPTION	AIR
412 001 009	Litre counter for polypropylene (PP) pump	G 1"

### INDUSTRIAL ELECTRIC PUMPS

Electrically operated devices made with technical characteristics and materials to optimise pumping, transfer and dosing of hydrocarbons and highly corrosive liquid chemicals.

#### PP/STAINLESS-STEEL PUMPS FOR ACIDIC AND BASIC PRODUCTS



- Absorption of installed power: 500 W
- Viscosity: 500 mPas
- Capacity: 87 L/min
- Temperature: 50°C max.
- Head: 19 water column meters
- Internal ventilation

Model for liquids with low viscosity, such as sodium chloride, ammonia solutions, formic acid and acetic acid.

Materials: Body (PP) - Impeller (PP) - Shaft (AISI 316)

CODE	DESCRIPTION	SUCTION HEIGHT
412 001 014	Industrial electric pump in PP for alkalis	1000 mm
412 001 015		1200 mm

Model for liquids with low viscosity, such as hydrochloric acid, battery acids, iron chloride, phosphoric acid, chromic acid and citric acid.

Materials: Body (PP) - Impeller (PP) - Shaft (Hastelloy C)

CODE	DESCRIPTION	SUCTION HEIGHT
412 001 016	Industrial electric pump in PP for acids	1000 mm
412 001 017		1200 mm

CODE	DESCRIPTION	AIR
412 001 018	Litre counter for electric pump (for acids and alkalis)	G 1" ¼



#### PVDF PUMPS FOR HIGHLY CONCENTRATED ACIDS AND ALKALIS



- Materials: Body (PVDF) - Impeller (ETFE) - Shaft (Hastelloy C4)
- Absorption of installed power: 460 W
- Viscosity: 500 mPas
- Capacity: 78 lt/min
- Temperature: 100°C max.
- Head: 16 water column meters
- External ventilation

Ideal for hydrochloric acid, chromic acid, sulphuric acid, nitric acid, hydrofluoric acid and sodium hypochlorite.

CODE	DESCRIPTION	SUCTION HEIGHT
412 001 019	Industrial electric pump in PVDF for concentrated acids and alkalis	1000 mm
412 001 020		1200 mm

CODE	DESCRIPTION	AIR
412 001 021	Litre counter in PVDF for electric pump (concentrated acids and alkalis)	G 1" ¼



Pictures indicated in this catalogue are representative and not binding for the supplier in terms of layout and colours. They may be subject to changes by the supplier without prior notice.

## ATEX AISI 316 PUMPS FOR FLAMMABLE PRODUCTS



Pump for highly flammable products, ethanol, benzene, butane, isopropyl alcohol, kerosene, methanol and petrol. Electric motor: MA II 3, 460 W, with external ventilation. Pneumatic motor: MD - 2, 400 W / 6 bar. Explosion proofing compliant with directive 2014/34/EU- ATEX, category 2.

- Materials: Body (AISI 316) - Impeller (ETFE) - Shaft (AISI 316)
- Temperature: 100°C max.
- Power draw: 460 W
- Viscosity: 350 mPas
- Head: 14 water column meters
- Capacity: 95 L/min

CODE	DESCRIPTION	SUCTION HEIGHT
412 001 022	ATEX pump in AISI 316 with electric motor	1000 mm
412 001 023	ATEX pump in AISI 316 with electric motor	1200 mm



- Materials: Body (AISI 316) - Impeller (ETFE) - Shaft (AISI 316)
- Temperature: 100°C max.
- Power draw: 1000 W
- Viscosity: 1000 mPas
- Head: 35 water column meters
- Capacity: 124 L/min

CODE	DESCRIPTION	SUCTION HEIGHT
412 001 024	ATEX pump in AISI 316 with pneumatic motor	1000 mm
412 001 025	ATEX pump in AISI 316 with pneumatic motor	1200 mm

## ATEX CERTIFIED STAINLESS-STEEL LITRE COUNTER



Stainless steel litre counter for highly flammable products, methanol, benzene, isopropyl alcohol, kerosene, formic acid, acetone, styrene, xylene, toluene, etc.

- Chamber and turbine: Stainless steel
- Seal: FEP
- Magnet: encapsulated ETFE
- LCD display: Character height 19 mm, 6-digit display, partial or total display
- Field of measurement: 10 - 100 L/min
- Viscosity field: 5,000 mPas
- Working pressure: 10 bars
- Precision: ± 1%
- Protection grade: IP 54
- Temperature: 60°C
- ATEX rating: II 2 G Ex ib II B T4

CODE	DESCRIPTION	AIR
412 001 026	Litre counter for ATEX pump	G 1" ¼



## LITRE COUNTER FOR PUMPS

### POLYPROPYLENE (PP) OR PVDF LITRE COUNTER



Polypropylene (PP) version for neutral and corrosive products such as glycols, iron chloride, hydrochloric acid, phosphoric acid, etc.  
PVDF version for highly corrosive products such as chloride, nitric acid, sulphuric acid, etc.

- External body: PP
- Keypad: PES
- Chamber and turbine: PP / PVDF
- Shaft and bearings: Hastelloy C4
- Seal: FPM
- Field of measurement: 5-90 L/min
- Viscosity field: 0.8 - 40 mPas
- Working pressure: 4 bar (at 20°C)
- Precision:  $\pm 1\%$
- Repeatability:  $\pm 0.5\%$
- Protection grade: IP 65
- Temperature:  $-10^\circ / + 50^\circ \text{C}$

CODE	DESCRIPTION	AIR
412 001 009	PP litre counter for neutral and corrosive products	G1"
412 001 021	PVDF litre counter for highly corrosive products	G1" 1/4

### TOUCHSCREEN LITRE COUNTER



Litre counter with touch-screen display, multilingual menu, intuitive and easy to use. Integrated help function. High precision thanks to the correction factors which can be adjusted to the specific product.

- External body: PP or stainless steel
- 63x63 mm, 128x128 pixel touchscreen
- Seal: FPM or FEP
- Field of measurement: 10-100 L/min
- Viscosity range: up to 5000 mPas
- Working pressure: 4 - 10 bar
- Precision:  $\pm 1\%$
- Repeatability:  $\pm 0.5\%$
- IP55 @ 80°C

CODE	DESCRIPTION	AIR
412 003 069	Touchscreen PP litre counter for neutral and corrosive products	G1" 1/4
412 003 070	Touchscreen stainless-steel litre counter for highly corrosive products	G1" 1/4

### DIGITAL LITRE COUNTER



- Easy to install on the line or at the end of the delivery pipe or directly on the gun
- Compact, easy-to-read display
- Rotating display in 4 different positions, runs on 2 easy-to-replace batteries
- Pulse signals: mono-channel, reed switch
- Flow rate indication
- Electronic card with LCD display: 5-digit partial total and 6-digit total
- Available with resettable total

CODE	DESCRIPTION	AIR
412 000 996	Digital litre counter	1" BSPM

### MECHANICAL LITRE COUNTER



- Designed to precisely measure the delivered quantity of diesel
- Available also for lubricants
- Low flow resistance also for gravity use
- 3 digit partial indicator (Max 999 L), total 6 digits
- Right to left flow direction

CODE	DESCRIPTION	AIR
412 000 966	Mechanical litre counter	1" BSP

## MIXER PUMPS

Dual-function pumps: mixing and pumping. Emulsions, dispersions and suspensions often tend to separate: in these cases, before pumping the liquids, the mixer pump ensures it is carefully mixed and homogenised. Ideal for: corrosive and neutral products. Motor: MA II 3, 460 W, with external ventilation.

### POLYPROPYLENE (PP) MIXER PUMP



- Body material: PP / PVDF
- Rotor material: PP
- Seal: Viton
- Mechanical seal: Carbon, SiC, Viton, HC
- Bearings: ETFE / PTFE
- Shaft material: Stainless steel
- Impeller type: L
- Pipe diameter: up to 50 mm
- Temperature: up to 50°C
- Pipe length: 1000 mm

CODE	DESCRIPTION	AIR
412 001 031	Polypropylene (PP) mixer pump	G1" 1/4 male
CODE	DESCRIPTION	
412 002 128	Kit: Gun for polypropylene (PP) mixer + 3 m pipe	

### STAINLESS STEEL MIXER PUMP



- Body material: stainless steel
- Rotor material: ETFE
- Seal: Viton
- Mechanical seal: Carbon, Ceramic, PTFE, stainless steel, HC.
- Bearings: Pure carbon
- Shaft material: Stainless steel
- Impeller type: R
- Pipe diameter: up to 41 mm
- Temperature: up to 100°C
- Pipe length: 1000 mm

CODE	DESCRIPTION	AIR
412 001 032	Stainless steel mixer pump	G1" 1/4 male
CODE	DESCRIPTION	
412 002 411	Kit: Gun for stainless steel mixer + 3 m pipe	

## FUEL DISTRIBUTION SYSTEMS

Storage systems designed for transport and transfer of liquids via detailed solutions for diesel, petrol, urea and adblue. The range also includes ADR approved diesel tanks.

### POLYETHYLENE (PE) TANK FOR DIESEL TRANSPORTATION, ADR APPROVED, UN MARKING



Mobile diesel tank in linear polyethylene (PE) with rotary moulding, type approved by the Ministry of Transport to ADR standards, with marking.

Supplied with: aluminium filling cap, safety valve, transfer unit, slots for lifting by forklift when full, handles for lifting when empty and housings for positioning the fixing belts to the support base.

All inserts in aluminium of other material compatible with Diesel fuel.

#### CERTIFICATES:

- Commissioning/Initial inspection report issued by the Authorised Body
- CE Declaration of Conformity for the transfer unit
- Instruction manual for road use in compliance with ADR requirements and for the correct use of the transfer unit

Each container is type-approved and inspected individually by the authorised body on testing with the issue of the initial commissioning certificate, to be reviewed every 30 months with similar procedure, ADR VIBRATION TEST 2011 passed.



#### FEATURES

- 12 or 24 V pump with flow rate 45 L/min
- 4 m flexible hose
- Automatic gun
- 4 m power cable and pliers for battery connection
- 2" aluminium filling cap with safety valve
- Suction filter
- Optional: digital litre counter code 412000996
- 220 litre tank weight: 14 Kg

CODE	DESCRIPTION	CAPACITY
412 002 733	Polyethylene (PE) tank for ADR diesel transport • 601 x 912 x h 622 mm	220 L



## POLYETHYLENE (PE) TANKS FOR DIESEL TRANSPORTATION EXEMPT PER 1.1.3.1.C ADR



412 002 732



412 001 044

Rotary moulded linear polyethylene (PE) mobile diesel tank with a compact yet lightweight structure.

Supplied with: aluminium filling cap, safety valve, transfer unit, slots for lifting by forklift when full, handles for lifting when empty and housings for positioning the fixing belts to the support base. All inserts in aluminium or other material compatible with Diesel fuel.

### FEATURES

- 12 or 24 V pump with flow rate 45 L/min
- 4 m flexible hose
- Automatic gun
- Level indicator and lockable cover (only for 440 litre model)
- 4 m power cable and pliers for battery connection
- 2" aluminium filling cap with safety valve.
- Suction filter
- Optional: digital litre counter code 412000996
- 220 litre tank weight: 14 Kg
- 440 litre tank weight: 42 Kg

CODE	DESCRIPTION	CAPACITY
412 002 732	Polyethylene (PE) tank for diesel transport, ADR exempt 601 x 912 x h 622 mm	220 L
412 001 044	Polyethylene (PE) tank for diesel transport, ADR exempt 800 x 1200 x h 785 mm	440 L

## POLYETHYLENE (PE) TANKS FOR UREA TRANSPORT AND STORAGE



412 002 852



412 002 853

Mobile tank made from rotary moulded linear polyethylene (PE) complete with 2" filling cap with safety valve, slots for lifting when full with fork lift, handle for lifting when empty and housings for positioning the fixing belts to the support base. All inserts produced in materials compatible with the contained product.

### FEATURES

- 12 or 24 V pump with flow rate 45 L/min
- 4 m flexible hose
- Automatic gun
- 4 m power cable and pliers for battery connection
- Level indicator and lockable cover (only for 440 litre model)
- Optional: digital litre counter code 412000996
- 220 litre tank weight: 14 Kg
- 440 litre tank weight: 42 Kg

CODE	DESCRIPTION	CAPACITY
412 002 852	Polyethylene (PE) tank for urea transport and storage 601 x 912 x h 622 mm	220 L
412 002 853	Polyethylene (PE) tank for urea transport and storage 800 x 1200 x h 785 mm	440 L



### POLYETHYLENE (PE) CONTAINERS FOR DIESEL, PETROL AND ADBLUE TRANSPORT



412 002 846



412 002 849



412 002 851

Rotary moulded linear polyethylene (PE) containers, ideal for refuelling small, lightweight and leisure vehicles; excellent handling and lifting with the ergonomic grip handle, fitted with pneumatic wheels for moving on any surface. Structure with no corners and reinforced ribbing for added strength; non-spill filling cap with built-in vent and safety ball valve. The container may be filled horizontally or vertically with the same amount of fuel.

#### FEATURES

##### TYPE-APPROVED PETROL CONTAINER KIT

- Aluminium vane rotary hand pump
- Rubber hose (3 m)
- Gun with manual stop and frontal gun-holder support

##### DIESEL CONTAINER KIT

- 12 or 24 V electric pump with flow rate 45 L/min
- Rubber hose (3 m)
- Gun with manual stop and frontal gun-holder support
- Battery connection cable (4 m) + pliers

##### ADBLUE CONTAINER KIT

- Rotary diaphragm hand pump
- Rubber hose (3 m)
- Plastic hand gun with frontal gun-holder support

CODE	DESCRIPTION	CAPACITY
412 002 846	Polyethylene (PE) container for petrol transport • 360 x 460 x h 900 mm	55 L
412 002 848	Polyethylene (PE) container for diesel transport • 360 x 460 x h 900 mm	55 L
412 002 849	Polyethylene (PE) container for diesel transport • 440 x 460 x h 1100 mm	110 L
412 002 850	Polyethylene (PE) container for AdBlue transport • 360 x 460 x h 900 mm	55 L
412 002 851	Polyethylene (PE) container for AdBlue transport • 440 x 460 x h 1100 mm	110 L

## APPROVED DIESEL TANK WITH DISPENSING UNIT



The tanks are horizontal axis, cylindrical, built with rounded bottoms and calendered carbon steel sheet S 235 JR UNI EN 10025, assembled by arc welding process under gas protection and subsequently treated with a layer of rust proofing and a final layer of green enamel; they are tested for tightness by pneumatic test. The tanks are also equipped with a dispensing system.

### FEATURES

- Ø 400 mm manhole with bolted cover and gasket
- Ring nut with 3" quick coupling, and padlockable closure
- Load limiting valve, approved and calibrated to 90% of the tank geometric capacity
- Level indicator visible from the outside with internal protection tube for the float
- Bottom drain for periodic cleaning complete with safety cap
- External suction pipe
- Grounding
- Ventilation with flame-retardant mesh, 240 cm from the loading surface
- With 4 anchor bars
- Containment sump: made of carbon steel S 235 JR UNI EN 10025 with self-supporting base frame designed for fixing with bolts to the feet of the tank; this containment sump can be positioned on any ground (even permanently). Containment sumps basins are designed and manufactured with a capacity equal to 110% of the nominal volume of the tank, as prescribed by the safety directives of Ministerial Decree 22.11.2017. Complete with lifting plates, earthing coupling and sleeve with drainage cap, 4 housings for assembly and fixing of roof posts Fully treated with rustproofing undercoat and painted with an enamel top layer.
- Cabinet: made of powder coated metal and equipped with a key lock. Electrical panel contained in a special box with IP 55 protection degree complete with switch, emergency button and pump block control when the minimum level is reached. Self-priming electric vane pump, capacity 50L/min, built-in by-pass and line filter, 230v single-phase electric motor (also available with manual pump or with battery pump). Non-commercial meters with resettable partial and progressive totalizer. (exempted from metric verification according to Ministry Circular no. 67 of 25.7.96). 4 m of rubber tube complete with automatic dispensing gun.

CODE	DESCRIPTION	CAPACITY
412 004 585	Approved diesel tank with dispensing unit and containment sump. Tank dimensions: Ø 1100 mm x 1500 mm • Sump size: 2250 x 1400 x h 480 mm	1300 L
412 004 586	Approved diesel tank with dispensing unit and containment sump. Tank dimensions: Ø 1270 x 2050 mm • Sump size: 2400 x 1750 x h 650 mm	2400 L
412 004 587	Approved diesel tank with dispensing unit and containment sump. Tank dimensions: Ø 1430 x 2080 mm • Sump size: 2450 x 1900 x h 750 mm	3000 L



Protective roof in strong galvanized carbon steel frame with self-supporting ribbed steel roof; designed for assembly and fixing with bolts to the housings in the containment sump.

CODE	DESCRIPTION
412 004 588	Removable cover for 1300 litre tank • 2600 x 2000 x h 1900 mm
412 004 589	Removable cover for 2400 litre tank • 2800 x 2000 x h 2100 mm
412 004 590	Removable cover for 3000 litre tank • 2800 x 2500 x h 2100 mm

### UREA DISPENSING UNIT FOR IBCS



Distribution, suction and metering system specifically for 1000-litre IBCs containing urea.

#### DISPENSING UNIT WITHOUT LITRE COUNTER:

- Stainless steel support plate with gun holder
- Electric pump, flow rate 32 L/min
- Hand gun
- 6m delivery hose
- 1.5 m suction pipe
- Hose holder and clamps

#### DISPENSING UNIT WITH LITRE COUNTER:

- Stainless steel support plate with gun holder
- Electric pump, flow rate 32 L/min
- Litre counter unit
- Stainless steel automatic gun
- 6m delivery hose
- 1.5 m suction pipe
- Hose holder and clamps

CODE	DESCRIPTION	POWER SUPPLY	POWER
412 001 152	Manual urea dispensing unit for IBC, without litre counter	230 Volt /50 Hz	370 W
412 001 153	Automatic urea dispensing unit for IBC, with litre counter	230 Volt /50 Hz	370 W

### UREA TANK



Horizontal cylindrical tank in high density polyethylene HDPE for urea of a maximum concentration of 30% at atmospheric pressure.

#### FEATURES

- Lightweight and easy to handle
- Impact- and chemical-resistant
- Resistant to temperatures from -60°C to +80°C
- Resistant to UV radiation
- Algae resistant
- Easily washed with normal detergents
- Complete with upper Ø 420 mm hatch with screw cover
- Equipped with vent valve

#### FEATURES

##### ELECTRIC PUMP

- 230 V single-phase diaphragm pump
- Easily removable dispensing unit contained in a lockable metal box
- Fitted with LCD litre counter
- Equipped with automatic-stop pistol and delivery hose (Ø 20 mm x 4 m)

Available with hose with bottom valve with filter or CDS type quick connector

ON REQUEST

CODE	DESCRIPTION	CAPACITY
412 001 154	Tank for urea • Ø 1600 x 1850 x h 1660 mm	3000 L

#### WHAT IS UREA?

Urea is a nitrogen fertiliser used commonly for its high nitrogen content. Recently it has also been used as the main component of an additive used to reduce the polluting content of industrial nitrogen oxide emissions (Post-Combustion NOx reduction).

It is also now used in heavy plant running on Diesel engines. It is injected in a 32.5% aqueous solution of pure urea into the exhaust manifold and, through a chemical reduction facilitated by suitable catalysts, transforms nitrogen oxides into molecular nitrogen and water.

## ADR APPROVED POLYETHYLENE (PE) IBCS



412 001 052



412 003 283



412 001 753

Lightweight blow-moulded polyethylene (PE) IBCs with galvanized steel cage for protection during transport.

### FEATURES

- Upper threaded hatch Ø 220 mm
- Palletised, stackable safety structure
- 2" bottom ball valve

CODE	DESCRIPTION	CAPACITY
412 001 052	Polyethylene (PE) IBC approved for transport (ADR) • 1200 x 1000 x h 1150 mm • PLASTIC PALLET	1000 L
412 003 283	Polyethylene (PE) IBC approved for transport (ADR) • 1200 x 1000 x h 1150 mm • HYBRID PALLET	1000 L
412 001 753	Polyethylene (PE) IBC approved for transport (ADR) • 1200 x 1000 x h 1150 mm • WOODEN PALLET	1000 L
412 003 650	Polyethylene (PE) IBC approved for transport (ADR) • 1200 x 1000 x h 1150 mm • PLASTIC PALLET	1000 L 

CODE	DESCRIPTION
412 001 053	Reduction for IBCs D 61 F - 2" F

## HEAT COVER FOR IBCS



Efficient heat cover for IBCs, uses much less energy than band heaters. Quick, easy and cost-effective way of heating and maintaining a constant temperature of industrial materials.

### FEATURES

- Polyester jacket
- Silicone insulated coil resistance
- Adjustable straps with quick opening
- Heating lasts up to 48 hours
- 3 m power cord
- Dual power-supply circuit without plug
- 0-90°C thermostat
- Protection IP 40

CODE	DESCRIPTION	POWER
412 003 736	Heat cover for IBCs • 4400 x 1000 mm	2 x 1000 W

CODE	DESCRIPTION
412 003 737	Insulating cover for IBCs



## HEAT COVER FOR IBCS ATEX APPROVED



ATEX approved IBC heat cover compliant with directive 94/9/EG, DIN EN 60079-0, DIN EN 60079-7, DIN EN 60079-30, DIN EN 13463-12. Quick, easy and cost-effective way of heating and maintaining a constant temperature of industrial materials, using much less energy than band heaters.

## FEATURES

- Teflon (PTFE)/polyester jacket
- Adjustable straps for quick opening
- Protection IP65
- Thermostat up to 50°C

## OPTIONAL

- Thermostat for temperature regulation
- Insulating cover

CODE	DESCRIPTION	POWER
412 002 426	Heat cover for IBCs ATEX approved 4400 x 1000 mm	1500 W

## INSULATING COVERS FOR IBCS



These heat covers are designed to provide optimal protection from UV rays, blocking direct UV light and deflecting radiation and heat, allowing the containers to be transported or positioned outdoors without causing damage to the contents. They are composed of air bubbles and a layer of aluminium.

CODE	DESCRIPTION	DIMENSIONS
412 003 817	Insulating cover for standard IBCs with opening for cap	4400 x h 1000 mm





## CUBOIL

 AIRBANK PRODUCT

### Used oil storage unit

Temporary storage unit for used oils complete with:

- Palletised steel sump
- Polyethylene (PE) container
- Threaded hatch
- Removable filter
- Clock level indicator
- Stainless steel flame arrestor with active carbon filter
- Safety labelling

### INTERNAL CONTAINER FEATURES

Parallelepiped shaped self-supporting container in non-oil, acid-proof, anti-UV treated polyethylene (PE) for permanent exposure to atmospheric agents, in compliance with DIN and AFNOR standards, single reinforced mould. Top filling mouth with threaded cover.

### EXTERNAL TANK FEATURES

2 mm carbon steel construction. Bent with a fibre system with reinforced structure. Painted (RAL 6018 green).

### TROLLEY FEATURES (WHERE APPLICABLE)

High capacity trolley with 2 fixed rubber and steel wheels and 2 rotating castors (1 with brake), steering mechanism.



## CUBOIL

USED OIL STORAGE UNIT

CODE	DESCRIPTION	CAPACITY
412 001 063	CUBOIL with feet • 545 x 795 x h 850 mm	300 L
412 001 064	CUBOIL with feet and cover • 545 x 795 x h 920 mm	
412 001 065	CUBOIL with castors • 545 x 795 x h 970 mm	
412 001 066	CUBOIL with castors and cover • 545 x 795 x h 1040 mm	

CODE	DESCRIPTION	CAPACITY
412 001 067	CUBOIL with feet • 640 x 900 x h 1050 mm	500 L
412 001 068	CUBOIL with feet and cover • 640 x 900 x h 1120 mm	
412 001 069	CUBOIL with castors • 640 x 900 x h 1170 mm	
412 001 070	CUBOIL with castors and cover • 640 x 900 x h 1240 mm	



REMOVABLE FILTER



LEVEL INDICATOR



FLAME ARRESTOR





CUBOIL  
for antifreeze



CUBOIL  
for used vegetable oil

### Special storage units for used vegetable oil or antifreeze

Temporary storage unit complete with:

- Palletised steel sump
- Polyethylene (PE) container
- Threaded hatch
- Removable filter
- Clock level indicator
- Stainless steel flame arrestor with active carbon filter for tank ventilation and to prevent harmful fume blasts on opening
- Safety labelling
- Load-bearing trolley
- Colour: RAL 5012 Blue (for antifreeze CUBOIL)
- Colour: RAL 6011 Green (for used vegetable oil CUBOIL)

CODE	DESCRIPTION	CAPACITY
412 001 073	Mobile CUBOIL for antifreeze • 545 x 795 x h 970 mm	300 L
412 001 074	Mobile CUBOIL for used vegetable oil • 545 x 795 x h 970 mm	300 L



# CUBOIL

USED OIL STORAGE UNIT

## POLYETHYLENE (PE) CONTAINERS FOR STORAGE OF USED MINERAL OIL



Trolley for handling even at full load with 4 castors, 2 with brake (forkliftable)

Container for collection and storage of used oil, built in compliance with Italian Legislative Decree no. 95 of 27 January 1992, and DM 392 of 16 May 1996. Also complies with directives 75/439/EEC and 87/101/EEC, concerning the disposal of used oils. Made from rotary moulded high density polyethylene (PE) to guarantee high mechanical and thermal resistance, high photometric resistance to UV rays and atmospheric agents; can also be installed outside and positioned on any ground or flat surface.

With 2 tanks: one internal product container, one external safety tank to contain any leakages from the inner container. Large upper mouth with tip-up cover with incorporated filter.

### FEATURES

- Practical level indicator visible from the outside
- Monitoring light, to check for any liquid in the cavity
- Aperture for oil removal with threaded cover, Ø mm 125
- Optional: lockable closure on suction cap
- Optional: trolley for handling even at full load with 4 castors, 2 with brake (forkliftable)

CODE	DESCRIPTION	CAPACITY
412 002 104	Polyethylene (PE) container for storage of used mineral oil Ø 820 x h 1080 mm	300 L
412 002 428	Polyethylene (PE) container for storage of used mineral oil Ø 960 x h 1240 mm	500 L

## POLYETHYLENE (PE) CONTAINERS FOR STORAGE OF ANTIFREEZE, BRAKE FLUID AND HYDRAULIC FLUID



412 002 891



412 002 892



412 002 893

Container for storage of industrial refuse in roto-moulded HDPE to guarantee high mechanical strength and chemical resistance, high resistance to UV radiation and weather. For this reason they can also be positioned outdoors and on any kind of flat ground.

### FEATURES

- Composed of two tanks: one internal product container, one external safety tank to contain any leakages from the inner container
- Large upper mouth with tip-up cover with incorporated perforated shelf which functions as a filter
- Aperture for oil removal with threaded cover, Ø mm 125
- Practical level indicator visible from the outside
- Monitoring light, to check for any liquid in the cavity
- Waste identification labelling

CODE	DESCRIPTION	CAPACITY
412 002 891	Polyethylene (PE) container for storage of antifreeze Ø 820 x h 1080 mm	300 L
412 002 892	Polyethylene (PE) container for storage of brake fluid Ø 820 x h 1080 mm	300 L
412 002 893	Polyethylene (PE) container for storage of hydraulic fluid Ø 820 x h 1080 mm	300 L

## POLYETHYLENE (PE) CONTAINER FOR STORAGE OF USED VEGETABLE OIL



Polyethylene (PE) container for used vegetable oil, manufactured in compliance with Italian Legislative Decree No. 95 of 27/01/92 and Ministerial Decree 392 of 16/05/96, implementing directives 75/439/EEC and 87/101/EEC.

### FEATURES

- Internal product tank
- Outer safety tank
- Incorporated filter
- Oil drain mouth with threaded cover and inner grille
- Visual level indicator
- Indicators for leaks
- Waste identification labelling

CODE	DESCRIPTION	CAPACITY
412 003 301	Polyethylene (PE) container for storage of used vegetable oil Ø 820 x h 1080 mm	300 L



### ECOTANKS FOR TEMPORARY STORAGE OF USED OIL COMPLIANT WITH DM NO. 392 OF 16 MAY 1996 ANNEX C

Made of S 235 JR UNI EN 10025 carbon steel with rounded, seamed base, painted exterior with a layer of rust proofing and a final layer of enamel.



#### FEATURES

- Complete with hatch Ø 400 mm with bolted cover
- 8" filling/emptying cap with aluminium screw cap
- Tested for tightness at a pressure of 1 bar
- With spill sump with 100% tank volume capacity
- Regulation active carbon vent pipe
- Level indicator
- 5000 L and larger tanks fitted with non-slip steps and non-slip floor and handrail for easy operator access
- Containment sump: carbon steel construction S 235 JR UNI EN 10025 with self-supporting base frame designed for fixing with bolts to the feet of the tank; can be positioned on any ground (even permanently)
- Sump with 50% or 100% capacity of the nominal tank volume. Complete with lifting plates, earthing coupling and sleeve with drainage cap, 4 housings for assembly and fixing of roof posts
- Treated with rustproofing undercoat and painted green top layer
- Protective roof in strong galvanized carbon steel frame with self-supporting ribbed steel roof; designed for assembly and fixing with bolts to the housings in the containment sump.

CODE	DESCRIPTION	CAPACITY
412 001 093	Ecotank for temporary storage of used oils • 1250 x 1800 x h 1500 mm	1300 L
412 001 094	Ecotank for temporary storage of used oils • 1500 x 2450 x h 1670 mm	2400 L
412 001 095	Ecotank for temporary storage of used oils • 1520 x 2450 x h 1830 mm	3000 L
412 001 096	Ecotank for temporary storage of used oils • 1750 x 3210 x h 2000 mm	5000 L
412 001 097	Ecotank for temporary storage of used oils • 2100 x 3850 x h 2100 mm	7000 L

CODE	DESCRIPTION
412 001 098	Roof for 1300 L tank
412 001 099	Roof for 2400 L tank
412 001 100	Roof for 3000 L tank
412 001 101	Roof for 5000 L tank
412 001 102	Roof for 7000 L tank
412 001 103	Electric overflow sensor
412 001 104	Spill sensor

## TYPE-APPROVED TANKS FOR TRANSPORTATION OF DANGEROUS GOODS



Storage systems designed for transport and transfer of liquids via detailed solutions for diesel, petrol, urea, adblue and oil. The range also includes ADR approved diesel tanks. Polyethylene (PE) tanks with steel structure, UN approved for hazardous goods transport.

Each tank is individually type-approved and certified.

### FEATURES

- Cubic welded carbon steel frame
- Cover: Ø 150 mm
- Drainage ball valve: 1.5" or 1" (code 412 004 606)

CODE	DESCRIPTION	CAPACITY
412 004 606	Type-approved tank for transportation of dangerous goods 780 x 920 x h 1315 mm	500 L
412 001 105	Type-approved tank for transportation of dangerous goods 1030 x 1250 x h 1070 mm	750 L
412 001 106	Type-approved tank for transportation of dangerous goods 1045 x 1250 x h 1310 mm	1000 L
412 001 107	Type-approved tank for transportation of dangerous goods 1095 x 1095 x h 1460 mm	1200 L



### FEATURES

- Single piece welded carbon steel frame
- Cover: Ø 150 mm
- Drainage ball valve: 1.5"

CODE	DESCRIPTION	CAPACITY
412 001 108	Type-approved tank for transportation of dangerous goods 1330 x 2090 x h 1670 mm	1900 L
412 001 109	Type-approved tank for transportation of dangerous goods 1360 x 2390 x h 1750 mm	2400 L
412 001 110	Type-approved tank for transportation of dangerous goods 1570 x 2390 x h 2000 mm	3000 L

## VERTICAL CYLINDRICAL CONTAINERS FOR CHEMICAL STORAGE

These polyethylene (PE) containers solve the many problems involved in liquid storage. They have a self-supporting vertical cylindrical shape with flat bottom, rounded upper part with central operator access complete with threaded cover with built-in vent and flat area for application of loading units or other accessories. The design, calculated according to the liquid to be contained, requires no reinforcement. May be placed directly on a flat surface with no special precautions, fitted with impressed level viewer.



Also available  
in version for  
storage  
of water



CODE	DESCRIPTION	CAPACITY	COVER
412 001 111	Vertical cylindrical container for storage of chemicals • Ø 500 x h 750 mm	120 L	Ø 200 mm
412 001 112	Vertical cylindrical container for storage of chemicals • Ø 620 x h 850 mm	220 L	
412 001 113	Vertical cylindrical container for storage of chemicals • Ø 710 x h 980 mm	325 L	
412 001 114	Vertical cylindrical container for storage of chemicals • Ø 870 x h 1150 mm	575 L	Ø 310 mm
412 001 115	Vertical cylindrical container for storage of chemicals • Ø 1100 x h 1400 mm	1120 L	
412 001 116	Vertical cylindrical container for storage of chemicals • Ø 1100 x h 1950 mm	1625 L	
412 001 117	Vertical cylindrical container for storage of chemicals • Ø 1200 x h 1950 mm	2075 L	Ø 420 mm
412 001 118	Vertical cylindrical container for storage of chemicals • Ø 1310 x h 2050 mm	2530 L	
412 001 119	Vertical cylindrical container for storage of chemicals • Ø 1300 x h 2700 mm	3530 L	
412 001 120	Vertical cylindrical container for storage of chemicals • Ø 1600 x h 2450 mm	4500 L	
412 001 121	Vertical cylindrical container for storage of chemicals • Ø 1600 x h 3000 mm	5560 L	
412 001 122	Vertical cylindrical container for storage of chemicals • Ø 2000 x h 2350 mm	6760 L	
412 001 123	Vertical cylindrical container for storage of chemicals • Ø 2000 x h 3100 mm	8900 L	
412 001 124	Vertical cylindrical container for storage of chemicals • Ø 2250 x h 3100 mm	11470 L	
412 001 125	Vertical cylindrical container for storage of chemicals • Ø 2250 x h 4400 mm	16800 L	
412 001 126	Vertical cylindrical container for storage of chemicals • Ø 2500 x h 4800 mm	22200 L	

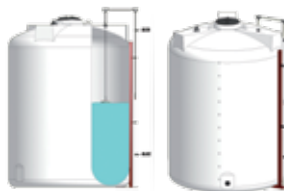
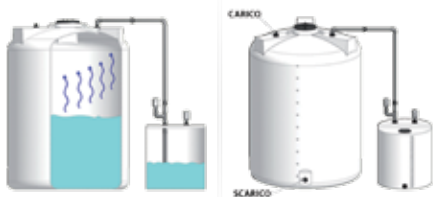

The cylindrical containers can be fitted with: Filling pipes, Overflow, Level viewer, Hydraulic guard.

ON REQUEST

## SPILL PALLETS FOR VERTICAL CYLINDRICAL TANKS

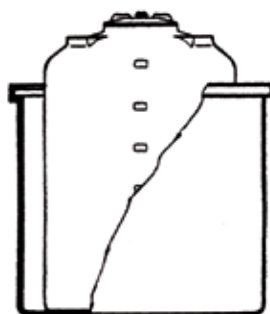

Polyethylene (PE) vertical spill pallets, self-supporting with flat base, full open mouth at the top with built-in upper reinforced edge. Designed for use as a safety or containment sump for vertical cylindrical containers, they can also be used as large tanks or as part of mixing units.

CODE	DESCRIPTION	CAPACITY
412 001 127	Spill pallets for vertical cylindrical tanks Ø 700 x h 450 mm	120 L
412 001 128	Spill pallets for vertical cylindrical tanks Ø 800 x h 600 mm	220 L
412 001 129	Spill pallets for vertical cylindrical tanks Ø 900 x h 660 mm	325 L
412 001 130	Spill pallets for vertical cylindrical tanks Ø 1300 x h 1000 mm	600 L
412 001 131	Spill pallets for vertical cylindrical tanks Ø 1350 x h 1050 mm	1200 L
412 001 132	Spill pallets for vertical cylindrical tanks Ø 1370 x h 1300 mm	1720 L
412 001 133	Spill pallets for vertical cylindrical tanks Ø 1600 x h 1450 mm	2600 L
412 001 134	Spill pallets for vertical cylindrical tanks Ø 1750 x h 1600 mm	3300 L
412 001 135	Spill pallets for vertical cylindrical tanks Ø 1950 x h 2100 mm	5500 L
412 001 136	Spill pallets for vertical cylindrical tanks Ø 2340 x h 2300 mm	8900 L
412 001 137	Spill pallets for vertical cylindrical tanks Ø 2550 x h 2450 mm	11500 L
412 001 138	Spill pallets for vertical cylindrical tanks Ø 2550 x h 3600 mm	17000 L



## HORIZONTAL CYLINDRICAL CONTAINERS FOR LIQUID AND WATER STORAGE

Horizontal cylindrical containers in polyethylene (PE) with built-in feet, can be placed on any flat surface with no special precautions, suitable for storing liquids. Upper hatch with threaded cover and built-in vent.



CODE	DESCRIPTION	CAPACITY	COVER
412 001 139	Horizontal cylindrical container for storage of liquids • 1050 x 625 x h 720 mm	300 L	Ø 210 mm
412 001 140	Horizontal cylindrical container for storage of liquids • 1250 x 750 x h 830 mm	510 L	Ø 310 mm
412 001 141	Horizontal cylindrical container for storage of liquids • 1350 x 900 x h 1000 mm	765 L	
412 001 142	Horizontal cylindrical container for storage of liquids • 1550 x 950 x h 1050 mm	1050 L	Ø 420 mm
412 001 143	Horizontal cylindrical container for storage of liquids • 1750 x 1100 x h 1200 mm	1510 L	
412 001 144	Horizontal cylindrical container for storage of liquids • 1700 x 1250 x h 1350 mm	2020 L	
412 001 145	Horizontal cylindrical container for storage of liquids • 2300 x 1100 x h 1200 mm	2030 L	
412 001 146	Horizontal cylindrical container for storage of liquids • 2400 x 1400 x h 1500 mm	3320 L	
412 001 147	Horizontal cylindrical container for storage of liquids • 2400 x 1800 x h 1950 mm	5200 L	
412 001 148	Horizontal cylindrical container for storage of liquids • 3100 x 2200 x h 2250 mm	11600 L	



CODE	DESCRIPTION	CAPACITY	COVER
412 002 429	Horizontal cylindrical container for storage of water 1050 x 625 x h 720 mm	300 L	Ø 210 mm
412 002 430	Horizontal cylindrical container for storage of water 1250 x 750 x h 830 mm	510 L	Ø 310 mm
412 002 431	Horizontal cylindrical container for storage of water 1350 x 900 x h 1000 mm	820 L	Ø 420 mm
412 002 432	Horizontal cylindrical container for storage of water 1550 x 950 x h 1050 mm	1150 L	
412 002 433	Horizontal cylindrical container for storage of water 1750 x 1100 x h 1200 mm	1650 L	
412 002 434	Horizontal cylindrical container for storage of water 1700 x 1250 x h 1350 mm	2190 L	
412 002 435	Horizontal cylindrical container for storage of water 2400 x 1400 x h 1500 mm	3460 L	
412 002 436	Horizontal cylindrical container for storage of water 2400 x 1800 x h 1950 mm	5600 L	
412 002 437	Horizontal cylindrical container for storage of water 2650 x 2000 x h 2100 mm	8000 L	
412 002 438	Horizontal cylindrical container for storage of water 3100 x 2200 x h 2250 mm	12600 L	

## STEEL CONTAINERS



Epoxy powder coated steel container.

Available with different shapes, dimensions and features to suit a wide range of different collection and disposal needs.

Stackable and tough.

Handling by forklift or pallet trucks (some models are with holes for upper lifting). RAL 5010.

### STEEL CONTAINERS



CODE	DESCRIPTION	TANK DEPTH	CAPACITY
413 001 156	Sheet metal container with feet 1000 x 800 x h 845 mm	650 mm	800 Kg
413 001 157	Sheet metal container with feet 1200 x 800 x h 845 mm	650 mm	800 Kg
413 001 158	Sheet-metal container with runners 1000 x 800 x h 845 mm	650 mm	1000 Kg
413 001 159	Sheet-metal container with runners 1200 x 800 x h 845 mm	650 mm	1000 Kg

Minimum order of 5 pcs per type

### "HEAVY-DUTY" SERIES SHEET-METAL CONTAINERS



CODE	DESCRIPTION	TANK DEPTH	CAPACITY
413 001 160	"Heavy duty" series sheet-metal container with runners • 1000 x 800 x h 910 mm	650 mm	1500 Kg
413 001 161	"Heavy duty" series sheet-metal container with runners • 1000 x 800 x h 910 mm	650 mm	2000 Kg
413 001 162	"Heavy duty" series sheet-metal container with runners • 1200 x 800 x h 910 mm	650 mm	1500 Kg
413 001 163	"Heavy duty" series sheet-metal container with runners • 1200 x 800 x h 910 mm	650 mm	2000 Kg

Minimum order of 5 pcs per type

### MESH SHEET METAL CONTAINER



CODE	DESCRIPTION	TANK DEPTH	CAPACITY
413 001 166	Container in mesh sheet metal with runners 1000 x 800 x h 860 mm	650 mm	1000 Kg

Minimum order of 5 pcs per type

### SHEET-METAL MESH CONTAINERS WITH FLAP



CODE	DESCRIPTION	TANK DEPTH	CAPACITY
413 001 167	Sheet-metal mesh container with flap and runners 1000 x 800 x h 995 mm	800 mm	1000 Kg
413 001 168	Sheet-metal mesh container with flap and runners 1200 x 800 x h 845 mm	650 mm	1000 Kg
413 001 169	Sheet-metal mesh container with flap and runners 1200 x 800 x h 995 mm	800 mm	1000 Kg
413 001 170	Sheet-metal mesh container with flap and feet 1200 x 1000 x h 1195 mm	1000 mm	1000 Kg

Minimum order of 5 pcs per type

### EMERGENCY CAGE



Safety cage for overhead maintenance with spring door and locking device, equipped with safety stop which prevents the container from coming off the forks and hooks for attachment of the safety harnesses. Complete with anti-slip Floor mat and tool tray.

High visibility RAL 2004 colour.

Equipment only for emergencies.

Not to be used under ordinary situations.

CODE	DESCRIPTION	CAPACITY
413 001 172	Emergency cage • 1000 x 1000 x h 1100 mm	400 Kg



## TILTING SCRAP SKIPS



Compliant with Dir. CE 42/2006

Containers specifically designed for collection and disposal of waste, swarf and scrap. Forkable directly by fork lift: easily tilted by the operator using a lever to empty them without getting off the forklift. Special emptying system minimises times wasting and the risk of accidents. Ideal for metalworking, grinding, foundries, glass factories, woodworking shops, etc.

Containers fitted with watertight sump, fitted with four castors (two fixed and two rotating), they are easily transported by hand when assembled. CE marking. RAL 5010.

Optional: opening cable.

CODE	DESCRIPTION	TANK DEPTH	TANK VOLUME	CAPACITY
413 004 030	Tilting scrap skip 970 x 750 x h 890 mm	700 mm	280 L	600 Kg
413 001 173	Tilting scrap skip 1350 x 820 x h 650 mm	490 mm	285 L	600 Kg
413 001 174	Tilting scrap skip 1350 x 920 x h 910 mm	700 mm	490 L	1000 Kg
413 001 175	Tilting scrap skip 1300 x 1070 x h 1030 mm	825 mm	755 L	1350 Kg
413 001 176	Tilting scrap skip 1550 x 1070 x h 1210 mm	970 mm	1070 L	1700 Kg
413 001 177	Tilting scrap skip 1550 x 1320 x h 1210 mm	970 mm	1320 L	2000 Kg
413 002 890	Tilting scrap skip 1500 x 2000 x h 1200 mm	980 mm	2000 L	2000 Kg



413 004 030



## DROP BOTTOM CONTAINERS



Container with opening base to hold and recycle waste products from mechanical workshops, joinery, paper mills etc.

Made of reinforced carbon steel for high density products with a lower hinged hatch available in one- or two-door version.

To empty the container contents, simply lift the container to a height that allows it to pass over a collection container. Having done this, the scrap can be removed by the operator, by pulling the lever with a cable (not included) sitting comfortably in the driver's seat. After emptying simply place the container on the ground and the bottom will automatically close back to the initial position. CE marking. RAL 5010.



Compliant with Dir. CE 42/2006

### Two-door

CODE	DESCRIPTION	TANK DEPTH	CAPACITY
413 001 184	Two-door container with opening bottom 1000 x 800 x h 870 mm	650 mm	2000 Kg
413 001 185	Two-door container with opening bottom 1000 x 800 x h 1220 mm	1000 mm	2000 Kg
413 001 186	Two-door container with opening bottom 1000 x 800 x h 1520 mm	1300 mm	2000 Kg
413 001 187	Two-door container with opening bottom 1500 x 1000 x h 800 mm	650 mm	2000 Kg
413 001 188	Two-door container with opening bottom 2000 x 1000 x h 1220 mm	1000 mm	2000 Kg

### Single door

CODE	DESCRIPTION	TANK DEPTH	CAPACITY
413 001 189	Single-door container with opening bottom 1000 x 800 x h 860 mm	650 mm	1300 Kg
413 001 190	Single-door container with opening bottom 1000 x 800 x h 1150 mm	1000 mm	1300 Kg

Single-door container with opening bottom. The container is equipped with high-capacity (450 kg ea.) casters, 2 rotating and 2 fixed Container suited to movement of bulky material.

### With wheels

CODE	DESCRIPTION	TANK DEPTH	CAPACITY
413 004 029	Single-door container with opening bottom, wheeled 1200 x 800 x 1094 mm	800 mm	1350 Kg
413 004 031	Single-door container with opening bottom, wheeled 1200 x 1000 1094 mm	800 mm	1350 Kg
413 004 032	Single-door container with opening bottom, wheeled 1500 x 1000 1094 mm	800 mm	1350 Kg



## INDUSTRIAL WASTE MANAGEMENT STATION



Structure comprising four independent safety containers for holding Big Bags with a perimeter frame. The frame has one opening side to facilitate handling of the single containers by forklift truck or pallet truck.

The four square carbon steel containers have a load-bearing base with upper servo-assisted hinged lid with 2 gas pistons.

**The containers are fitted with internal spring clips to hook on the Big Bags.**

### RAL Colours:

- RAL 5012 Light blue
- RAL 6018 Green
- RAL 1028 Yellow
- RAL 3000 Red



CODE	DESCRIPTION	DIMENSIONS OF SINGLE CONTAINER
413 001 198	Industrial waste management station 2020 x 2020 x h 1350 mm	960 x 960 x h 1350 mm
413 004 009	Industrial waste management station with guard and flame arrestor 2020 x 2020 x h 1350 mm	960 x 960 x h 1350 mm

CODE	DESCRIPTION
413 001 200	Customisable waste identification label

## HAZARDOUS WASTE CONTAINERS



Painted steel containers for separate waste collection of hazardous materials. Fitted with hinged cover with trigger-operated safety catch.

CODE	DESCRIPTION	CAPACITY
413 001 191	Hazardous waste container • 800 x 600 x h 650 mm	250 L
413 001 192	Hazardous waste container • 1000 x 700 x h 850 mm	500 L
413 001 193	Hazardous waste container • 1200 x 800 x h 950 mm	815 L

## BIG BAG HOLDER SAFETY CONTAINER



Square-shaped container for temporary storage of waste, with load-bearing body in carbon steel. Exterior corrosion-proofing treatment with antistatic polyurethane resins, visible colour. Available with removable upper lid or servo-assisted hinged lid with 2 gas springs (95° opening).

**Internal spring clips for fastening Big Bags.**

CODE	DESCRIPTION	DIMENSIONS
413 001 201	Big bag safety container with servo-assisted hinged lid	960 x 960 x h 1350 mm
413 001 202	Big bag safety container with removable lid	960 x 960 x h 1350 mm
413 004 011	Big bag safety container with servo-assisted hinged lid with mesh and flame protection	960 x 960 x h 1350 mm
413 004 012	Big bag safety container with removable lid with mesh and flame protection	960 x 960 x h 1350 mm

CODE	DESCRIPTION
413 001 200	Customisable waste identification label

## BIG BAG HOLDER WITH CONTAINMENT SUMP



413 001 204



413 004 793

Carbon steel Big Bag structure with external corrosion-proofing treatment. Equipped with containment sump for any leaks and removable bag holder structure resting on four pillars.

Colour: RAL 6018.

CODE	DESCRIPTION	DIMENSIONS
413 001 204	Big Bag holder with containment sump	1000 x 1000 x h 1850 mm
413 001 205	Big bag holder with containment sump and trolley	1000 x 1000 x h 2000 mm
413 004 793	Removable Big Bag holder with spill sump, roof and adjustable hooks	1000 x 1000 x h 1860 mm (of which 300 h sump + feet) <b>new</b>

CODE	DESCRIPTION
413 001 206	Hot galvanized carbon steel heavy duty grid
413 001 207	Half cover in soft PVC, UV treated w. rubber bands



Big Bag holder with trolley (413 001 205) and grid (413 001 206)

Pictures indicated in this catalogue are representative and not binding for the supplier in terms of layout and colours. They may be subject to changes by the supplier without prior notice.

## BIG BAG HOLDER WITH CONTAINMENT SPILL SUMP, ROOF AND ADJUSTABLE HOOKS



Removable Big Bag holder in painted steel, complete with 1150x1150 mm galvanized sheet roof, 4-drum spill sump, capacity 330 L, grid and 5-position height-adjustable hooks for fixing the big bag.  
RAL 6018

CODE	DESCRIPTION	DIMENSIONS
413 004 834	Removable Big Bag holder with spill sump, roof and adjustable hooks	1340 x 1250 x h 1860 mm (of which 300 h sump + feet)

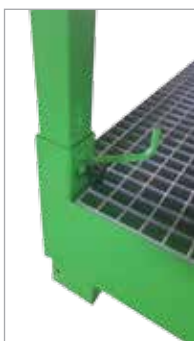

## DISMOUNTABLE BIG BAG HOLDER



Galvanized carbon steel removable Big Bag holder.  
With a safety hook for the Big Bag handles on each pillar.

CODE	DESCRIPTION	STRUCTURE DIMENSIONS
413 001 203	Dismountable Big Bag holder	1070 x 1070 x h 1350 mm



WATCH  
THE VIDEO





## REMOVABLE BIG BAG HOLDER WITH WHEELS



Galvanized carbon steel removable Big Bag holder.  
With a safety hook for the Big Bag handles on each pillar.  
Equipped with 4 pivoting wheels, two with brake – capacity 400 kg each Ø 150 mm

CODE	DESCRIPTION	DIMENSIONS
413 004 448	Removable Big Bag holder with wheels	1070 x 1070 x h 1350 (+ 150 mm wheels)

## NON-APPROVED BIG BAGS

### BIG BAG WITH POLYETHYLENE (PE) LINER



413 001 209

- Big Bag for non-hazardous waste and raw materials, with UV-protection treatment
- Polyethylene (PE) liner
- Equipped with 4 lifting straps
- Duffel top
- **Breaking point 5/1**

CODE	DESCRIPTION	CAPACITY	CAPACITY
413 001 208	Big bag with polyethylene (PE) liner • 900 x 900 x h 700 mm Bottom with discharge spout	500 L	1000 Kg
413 001 209	Big bag with polyethylene (PE) liner • 900 x 900 x h 1200 mm Closed bottom	1000 L	1000 Kg
413 001 210	Big bag with polyethylene (PE) liner • 900 x 900 x h 1800 mm Closed bottom	1400 L	1250 Kg

### BIG BAG WITH LINER FOR HAZARDOUS WASTE



- Big bag for hazardous waste
- Equipped with 4 lifting straps
- Duffel top
- With black "R" on yellow background
- **Breaking point 5/1**

CODE	DESCRIPTION	CAPACITY	CAPACITY
413 004 014	Big Bag for hazardous waste with liner 900 x 900 x h 1200 mm • Closed bottom	1000 L	1000 Kg

## BIG BAG WITHOUT LINER



- Big Bag for non-hazardous waste and raw materials, with UV-protection treatment
- Equipped with 4 lifting straps
- Duffel top
- **Breaking point 5/1**

CODE	DESCRIPTION	CAPACITY	CAPACITY
413 001 761	Big bag without liner • 900 x 900 x h 1200 mm Closed bottom	1000 L	1000 Kg
413 004 609	Big Bag without liner • 900 x 900 x h 1600 mm Closed bottom	1300 L	1500 Kg

## TYPE-APPROVED BIG BAGS FOR HAZARDOUS WASTE

### UN TYPE-APPROVED BIG BAGS FOR HAZARDOUS WASTE



413 001 212

- UN 13H 3/Y/... approved Big Bags
- Complete with liner
- With black "R" on yellow background, type approval number, A4 document pocket and sign
- Closed bottom
- Duffel top
- **Breaking point 6/1**

CODE	DESCRIPTION	CAPACITY	CAPACITY
413 004 015	UN approved Big bag • 500 x 500 x h 900 mm Closed bottom	230 L	500 Kg
413 001 211	UN approved Big bag • 800 x 800 x h 900 mm Closed bottom	500 L	500 Kg
413 001 212	UN approved Big bag • 900 x 900 x h 1200 mm Closed bottom • Stackable, 2000 g max	1000 L	1000 Kg 
413 001 213	UN approved Big bag • 900 x 900 x h 1800 mm Closed bottom	1400 L	1250 Kg

### UN APPROVED MINI BIG BAG



- UN UN 5H 3/Y50/S/... approved Big Bags
- Complete with liner
- With black "R" on yellow background, type approval number, A4 document pocket and sign
- **Breaking point 6/1**

CODE	DESCRIPTION	CAPACITY	CAPACITY
413 002 439	UN approved mini Big bag • 350 x 350 x h 750 mm Closed bottom	90 L	50 Kg

### UN APPROVED BIG BAG FOR ASBESTOS STORAGE



- To be used as the second container for packaging waste containing asbestos, pursuant to Italian Ministerial Decree of 6 September 1994
- Big bags designed to ensure full safety when handling and transporting asbestos and other dangerous waste
- Undergoing strict inspection tests, they are supplied with relevant certification issued by International authorities
- With UN approval for hazmat storage, compliant with ADR regulations
- **Breaking point 6/1**

CODE	DESCRIPTION	CAPACITY	CAPACITY
413 001 217	UN approved Big Bag for asbestos storage 900 x 900 x h 1200 mm • Closed bottom	1000 L	1000 Kg

### UN APPROVED BIG BAG FOR ASBESTOS HANDLING



- To be used as the first container for packaging waste containing asbestos, pursuant to Italian Ministerial Decree of 6 September 1994
- Innovative container for safe handling of asbestos slabs and pipes with asbestos coating
- UN 13H 3/Y approved
- Made of 100% polypropylene (PP) with polyethylene (PE) liner
- Complete with special lifting loops for the most common lifting devices
- **Breaking point 6/1**

CODE	DESCRIPTION	CAPACITY
413 001 218	UN approved big bag for asbestos handling 1100 x 1400 x h 800 mm	1000 Kg
413 001 219	UN approved big bag for asbestos handling 1100 x 2500 x h 500 mm	1000 Kg
413 001 220	UN approved big bag for asbestos handling 1100 x 3200 x h 500 mm	1000 Kg



## SPECIAL BIG BAGS

### FILTERING BIG BAG



- Made of looped fabric for mud dehydration
- Duffel top
- **Breaking point 5/1**

CODE	DESCRIPTION	CAPACITY	CAPACITY
413 001 214	Filtering Big bag • 900 x 900 x h 1200 mm Closed bottom	1000 L	1000 Kg

- Big Bag made of looped fabric for mud dehydration
- With TNT liner for different strain degrees
- Duffel top
- **Breaking point 5/1**

CODE	DESCRIPTION	CAPACITY	CAPACITY
413 001 215	Filtering Big Bag with nonwoven fabric liner 900 x 900 x h 1200 mm • Closed bottom	1000 L	1000 Kg

## ADR APPROVED POLYETHYLENE (PE) BAGS



- ADR approved high density polyethylene (HDPE) bag
- Polyethylene (PE) thickness: 80 µm
- Structure: full opening / flat bottom
- Printing: approval number, black "R" on yellow bottom
- Approval: 5H 4/Z/...

CODE	DESCRIPTION
413 002 447	ADR approved polyethylene (PE) bag • 900 x h 1100 mm • Flat bottom



## FLUORESCENT TUBE CONTAINER

Storage solution specifically developed for the temporary storage of fluorescent and neon lights.

Compliant with Italian Legislative Decree No. 49 of 14/03/2014, as amended

### TRANSPORTABLE CYLINDRICAL CONTAINER FOR STORAGE OF FLUORESCENT TUBES



Container for the safe storage of fluorescent tubes and bulbs, made of HDPE; with cover and handle for transport.

CODE	DESCRIPTION	DIMENSIONS
413 001 221	Transportable cylindrical container for storage of fluorescent tubes	Ø 210 x 600 mm
413 001 222	Transportable cylindrical container for storage of fluorescent tubes	Ø 210 x 1200 mm
413 001 223	Transportable cylindrical container for storage of fluorescent tubes	Ø 210 x 1550 mm

### POLYETHYLENE (PE) CONTAINER FOR STORAGE OF FLUORESCENT TUBES



Polyethylene (PE) container for temporary storage of fluorescent tubes, with removable inner Big Bag.

Flap lid. Forkliftable.

Safety labelling according in force regulations.

CODE	DESCRIPTION	DIMENSIONS
413 001 224	Polyethylene (PE) container for storage of fluorescent tubes	1870 x 920 x h 1060 mm
CODE	DESCRIPTION	DIMENSIONS
413 001 225	Internal steel structure with four polyethylene (PE) trays for various electrical components	1835 x 440 x h 85 mm

### STEEL CONTAINER FOR STORAGE OF FLUORESCENT TUBES



Rectangular steel container for temporary storage of fluorescent light tubes and light bulbs. Removable inner Big Bag included.

Flap lid. Forkliftable.

Exterior corrosion-proof treatment by oil- and acid- proof polyurethane resins. Safety labelling according in force regulations.

CODE	DESCRIPTION	DIMENSIONS
413 001 226	Steel container for storage of fluorescent tubes	2080 x 580 x h 600 mm
CODE	DESCRIPTION	DIMENSIONS
413 001 227	Internal steel structure with four polyethylene (PE) trays for various electrical components	2010 x 440 x h 85 mm

### BIG BAG FOR FLUORESCENT TUBE CONTAINER STORAGE



Polypropylene fabric Big Bag for fluorescent tubes. Equipped with lifting straps.

CODE	DESCRIPTION	DIMENSIONS
413 001 228	Big Bag for steel fluorescent tube container storage	2000 x 500 x h 500 mm
413 001 229	Big Bag for polyethylene (PE) fluorescent tube container storage	1700 x 800 x h 700 mm

## CONTAINERS FOR STORING USED BATTERIES

Compliant with the provisions of Article 235 of Italian Legislative Decree 152/2006 and Legislative Decree 188/2008

### HDPE CONTAINERS WITH STEEL FRAME FOR STORAGE OF USED BATTERIES



Made from oil, acid and impact-resistant polyethylene (PE), UV protected, for constant exposure to atmospheric agents. Reinforced carbon-steel frame allows container stacking, lifting, forklifting and tilting. Identification labelling.

CODE	DESCRIPTION	CAPACITY
413 001 230	HDPE container with reinforcement frame • 920 x 710 x h 840 mm	250 L
413 001 231	HDPE container with reinforcement frame • 1130 x 830 x h 1040 mm	550 L
413 001 232	HDPE container with reinforcement frame • 1350 x 1170 x h 1040 mm	850 L

### HDPE CONTAINER WITH STEEL PERIMETER REINFORCEMENT FOR STORAGE OF USED BATTERIES



Made from oil, acid and impact-resistant polyethylene (PE), UV protected, for constant exposure to atmospheric agents. WATERTIGHT carbon-steel reinforcement frame. Identification labelling.

CODE	DESCRIPTION	CAPACITY
413 001 233	HDPE container with watertight structure • 920 x 710 x h 840 mm	250 L
413 001 234	HDPE container with watertight structure • 1130 x 830 x h 1040 mm	550 L
413 001 235	HDPE container with watertight structure • 1350 x 1170 x h 1040 mm	850 L

## CONTAINERS FOR STORAGE OF HAZARDOUS WASTE

Compliant with the provisions of Legislative Decree 152/2006

### HDPE CONTAINERS WITH STEEL FRAME FOR HAZARDOUS WASTE COLLECTION



Made from oil, acid and impact-resistant polyethylene (PE), UV protected, for constant exposure to atmospheric agents. Reinforced carbon steel frame for container stacking, lifting, forklifting and tilting. Identification labelling.

CODE	DESCRIPTION	CAPACITY
413 001 236	HDPE container with reinforcement frame • 920 x 710 x h 840 mm	250 L
413 001 237	HDPE container with reinforcement frame • 1130 x 830 x h 1040 mm	550 L
413 001 238	HDPE container with reinforcement frame • 1350 x 1170 x h 1040 mm	850 L

### HDPE CONTAINER WITH STEEL PERIMETER REINFORCEMENT FOR HAZARDOUS WASTE COLLECTION



Made from oil, acid and impact-resistant polyethylene (PE), UV protected, for constant exposure to atmospheric agents. WATERTIGHT carbon-steel reinforcement frame. Identification labelling.

CODE	DESCRIPTION	CAPACITY
413 001 239	HDPE container with watertight structure • 920 x 710 x h 840 mm	250 L
413 001 240	HDPE container with watertight structure • 1130 x 830 x h 1040 mm	550 L
413 001 241	HDPE container with watertight structure • 1350 x 1170 x h 1040 mm	850 L

### STACKABLE INDUSTRIAL CONTAINERS

Industrial injection moulded containers in polypropylene (PP) resins, acid- and solvent- resistant. Resilient and sturdy structure, stackable.

Available with feet, standard wheels or runners, and fitted with covers.

Special fittings with safety labelling available for different products and waste.

Equipped with two side emptying valves, to be opened when needed, which can be fitted with screw caps or resin ball valves. The container is supplied without holes (perforations can be made on request).



#### WITH COVER

CODE	DESCRIPTION	DIMENSIONS	CAPACITY
413 001 242	Stackable industrial container with feet	Outside: 1000 x 700 x h 700 mm • Inside: 940 x 640 x h 500 mm	300 Kg
413 001 243	Stackable industrial container with wheels	Outside: 1000 x 700 x h 790 mm • Inside: 940 x 640 x h 500 mm	300 Kg
413 001 244	Stackable industrial container with runners	Outside: 1000 x 700 x h 700 mm • Inside: 940 x 640 x h 500 mm	300 Kg
413 001 245	Stackable industrial container with feet	Outside: 1200 x 800 x h 900 mm • Inside: 1130 x 725 x h 690 mm	500 Kg
413 001 246	Stackable industrial container with wheels	Outside: 1200 x 800 x h 990 mm • Inside: 1130 x 725 x h 690 mm	500 Kg
413 001 247	Stackable industrial container with runners	Outside: 1200 x 800 x h 900 mm • Inside: 1130 x 725 x h 690 mm	500 Kg
413 002 754	Stackable industrial container with feet	Outside: 1200 x 1000 x h 830 mm • Inside: 1120 x 920 x h 655 mm	600 Kg
413 002 755	Stackable industrial container with wheels	Outside: 1200 x 1000 x h 980 mm • Inside: 1120 x 920 x h 655 mm	600 Kg
413 002 756	Stackable industrial container with runners	Outside: 1200 x 1000 x h 830 mm • Inside: 1120 x 920 x h 655 mm	600 Kg

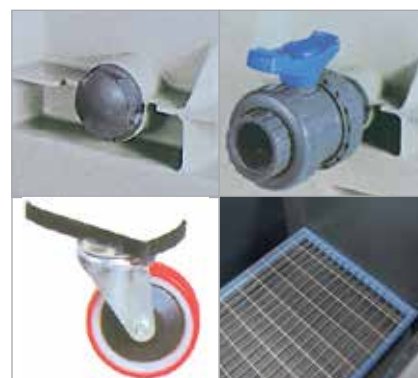

CODE	BASE
413 001 248	1" ¼ screw cap
413 001 249	1" ¼ ball valve
413 001 250	Polyurethane wheels
413 001 200	Customisable waste identification label

Food version available



ON REQUEST

Pictures indicated in this catalogue are representative and not binding for the supplier in terms of layout and colours. They may be subject to changes by the supplier without prior notice.

## CONTAINERS FOR STORAGE AND TRANSPORT OF USED BATTERIES



ADR approved containers for storage and transportation of used batteries (UN code no. 2794, 2795, 2800 and 3028).

Made of HDPE and resistant to battery acid.

Completely recyclable and resistant to UV radiation, as well as extreme temperatures: from - 40°C to + 60° C.

Stackable (up to 8 containers).

Compliant with the provisions of Art. 235 of Legislative Decree 152/2006 and Legislative Decree 188/2008



**FOR ADR COMPLIANT TRANSPORTATION, FIX THE COVER WITH STRAPS WITH COVER**

CODE	DESCRIPTION	DIMENSIONS	CAPACITY	TYPE APPROVAL
413 002 760*	Container for storage and transport of exhausted batteries	Outside: 1000 x 700 x h 650 mm Inside: 940 x 640 x h 500 mm	300 Kg	11H 2/Y300/S
413 000 936*	Container for storage and transport of exhausted batteries	Outside: 1200 x 800 x h 850 mm Inside: 1130 x 725 x h 690 mm	500 Kg	11H 2/L/S
413 002 762*	Container for storage and transport of exhausted batteries	Outside: 1200 x 1000 x h 830 mm Inside: 1120 x 920 x h 655 mm	500 Kg	11H 2/L/S

\* Depending on the production batch, the containers may be supplied in blue or grey.



You will also find SOLFORLESS on page 52 the neutralizer for sulphuric acid compliant with Italian Ministerial Decree no. 20 of 24.01.11

CODE	DESCRIPTION
413 002 440	Fastening straps

Code 413 000 936 is also type approved for the transport of lithium batteries. (UN 3091)





## NESTABLE AND STACKABLE CONTAINERS



Manufactured in PP, they are suitable for temporary storage and transport of various waste.

Resistant to temperatures from -10°C to 100°C.

Stack wings are also available for all models to allow stacking of containers. The insertable empties reduce dimensions.

CODE	DESCRIPTION	CAPACITY
413 001 351	Nestable and stackable container • 600 x 400 x h 410 mm	70 L
413 001 352	Nestable and stackable container • 800 x 400 x h 410 mm	100 L
413 001 353	Nestable and stackable container • 800 x 600 x h 550 mm	200 L

CODE	DESCRIPTION
413 000 229	Cover for 70 L containers
413 000 230	Cover for 100 L containers
413 000 231	Cover for 200 L containers
413 001 356	Stack wings for containers from 70 to 100 L
413 000 349	Stack wings for 200-litre containers
413 000 232	Castors for 70-litre containers
413 000 233	Castors for 100-litre containers
413 000 348	Castors for 200-litre containers

Food version available



ON REQUEST

## CROCODILE LID CONTAINERS



Polypropylene containers, ideal for organised distribution. With crocodile lid. Nestable with lid open, stackable with lid closed.

CODE	DESCRIPTION	CAPACITY
413 004 191	Crocodile lid container • 600 x 400 x h 265 mm	46 L
413 004 192	Crocodile lid container • 600 x 400 x h 315 mm	54 L
413 004 193	Crocodile lid container • 600 x 400 x h 365 mm	67 L

## STACKABLE CONTAINERS



Manufactured in PP, they are suitable for temporary storage and transport of various waste.

Resistant to temperatures from -10°C to 100°C.

They are impact resistant and resistant to chemicals and moisture, and use the entire surface area of Europallets, optimising the interior space thanks to their vertical walls. Stackable, with through or closed handles, they are ideal for pharmaceutical products, small mechanical parts and foodstuffs.

CODE	DESCRIPTION	CAPACITY
413 004 188	Stackable container • 400 x 300 x h 140 mm	12 L
413 004 189	Stackable container • 400 x 300 x h 220 mm	22 L
413 001 347	Stackable container • 600 x 400 x h 170 mm	30 L
413 001 348	Stackable container • 600 x 400 x h 220 mm	40 L
413 001 349	Stackable container • 600 x 400 x h 275 mm	50 L
413 001 350	Stackable container • 600 x 400 x h 320 mm	60 L

CODE	DESCRIPTION
413 004 190	Cover for 12 and 22 L containers
413 001 354	Cover for container from 30 to 60 L
413 001 355	Castors for container from 30 to 60 L



## POLYETHYLENE (PE) TRUNK



HDPE single moulded container, UV treated, corrosion-proof, resistant to lots of chemicals and shock absorbant. Design and material suitable for outdoor usage. Fitted with hinged lockable lid with wide opening and runners for forklift transport. Suitable for different applications, including storage of sand, salt and absorbent materials.

CODE	DESCRIPTION	CAPACITY
413 001 357	Polyethylene (PE) trunk • 1030 x 630 x h 680 mm	180 L

## POLYETHYLENE (PE) TROLLEY



Wheeled polyethylene (PE) container; easy to move around thanks to its ergonomic handles, it is ideal for numerous uses. (Storage of sand, salt, absorbents, animal feed, pellets etc.). Each trolley will be provided with gasket and lock.

CODE	DESCRIPTION	CAPACITY
413 004 324	Polyethylene (PE) trolley • 590 x 435 x h 1070 mm	75 L

## POLYETHYLENE MOBILE BOX APPROVED FOR TRANSPORT



Polyethylene (PE) box with wheels. For safe, clean storage of solid and hazardous waste, in ADR packaging groups II or III.

Approved for transport per regulations with the following type approval **1H 2W/Y100/S/15/D/...**

Blue body and cover (available in three different colours) with hermetic polyurethane seal and built-in handle for easy handling even with a full load. Specially shaped lid for storage of 8 boxes on a Euro pallet (stacked 4+4). Side grooves for easy grip and emptying with forklift trucks with rotating head. Locking by metal snap with release combination. Reserved location according to ADR identification labelling.

CODE	DESCRIPTION	COVER COLOUR
413 001 260	Polyethylene (PE) container with castors • 600 x 400 x h 880 mm	Red
413 001 261	Polyethylene (PE) container with castors • 600 x 400 x h 880 mm	Green
413 001 262	Polyethylene (PE) container with castors • 600 x 400 x h 880 mm	Blue

CODE	DESCRIPTION
413 001 200	Customisable waste identification label

# WHEELED CONTAINERS FOR SEPARATE COLLECTION



Containers for separated waste collection in high density polyethylene (HDPE), resistant to chemicals, parasite-proof, impermeable, washable and sterilisable. Complete with cover, wheels and carry handles. Available in 80, 120, 240 and 360 litre versions.



Compliant with EN 840-1:2012, EN 840-5:2012, EN 840-6:2012

CODE	DESCRIPTION	CAPACITY
413 003 287	Wheeled container for separate waste collection • 500 x 460 x h 920 mm • YELLOW	80 L
413 003 288	Wheeled container for separate waste collection • 500 x 460 x h 920 mm • BLUE	80 L
413 003 289	Wheeled container for separate waste collection • 500 x 460 x h 920 mm • RED	80 L
413 003 290	Wheeled container for separate waste collection • 500 x 460 x h 920 mm • BROWN	80 L
413 003 291	Wheeled container for separate waste collection • 500 x 460 x h 920 mm • GREY	80 L
413 003 292	Wheeled container for separate waste collection • 500 x 460 x h 920 mm • WHITE	80 L
413 003 293	Wheeled container for separate waste collection • 500 x 460 x h 920 mm • GREEN	80 L

Compliant with EN 840-1:2012, EN 840-5:2012, EN 840-6:2012

CODE	DESCRIPTION	CAPACITY
413 001 263	Wheeled container for separate waste collection • 550 x 500 x h 940 mm • YELLOW	120 L
413 001 264	Wheeled container for separate waste collection • 550 x 500 x h 940 mm • BLUE	120 L
413 001 265	Wheeled container for separate waste collection • 550 x 500 x h 940 mm • RED	120 L
413 001 266	Wheeled container for separate waste collection • 550 x 500 x h 940 mm • BROWN	120 L
413 001 267	Wheeled container for separate waste collection • 550 x 500 x h 940 mm • GREY	120 L
413 001 268	Wheeled container for separate waste collection • 550 x 500 x h 940 mm • WHITE	120 L
413 001 270	Wheeled container for separate waste collection • 550 x 500 x h 940 mm • GREEN	120 L

Compliant with EN 840-1:2012, EN 840-5:2012, EN 840-6:2012

CODE	DESCRIPTION	CAPACITY
413 001 271	Wheeled container for separate waste collection • 720 x 580 x h 1060 mm • YELLOW	240 L
413 001 272	Wheeled container for separate waste collection • 720 x 580 x h 1060 mm • BLUE	240 L
413 001 273	Wheeled container for separate waste collection • 720 x 580 x h 1060 mm • RED	240 L
413 001 274	Wheeled container for separate waste collection • 720 x 580 x h 1060 mm • BROWN	240 L
413 001 275	Wheeled container for separate waste collection • 720 x 580 x h 1060 mm • GREY	240 L
413 001 276	Wheeled container for separate waste collection • 720 x 580 x h 1060 mm • WHITE	240 L
413 001 278	Wheeled container for separate waste collection • 720 x 580 x h 1060 mm • GREEN	240 L

Compliant with EN 840-1 2013-03/DIN EN 840-5/-6: 2013-02

CODE	DESCRIPTION	CAPACITY
413 001 283	Wheeled container for separate waste collection • 865 x 620 x h 1110 mm • YELLOW	360 L
413 002 441	Wheeled container for separate waste collection • 865 x 620 x h 1110 mm • GREEN	360 L
413 002 442	Wheeled container for separate waste collection • 865 x 620 x h 1110 mm • BLUE	360 L







CODE	DESCRIPTION
413 002 443	Bag holder ring for 120 litre wheelie container
413 002 444	Bag holder ring for 240 litre wheelie container
413 002 445	Foot pedal for 120 L wheelie container cover
413 002 446	Foot pedal for 240 L wheelie container cover
413 001 284	Foot pedal for 360 L wheelie container cover
413 003 306	Polyethylene (PE) bags for 120 and 240 litre wheelie containers
413 001 286	Big Bag for 360 litre wheelie container
413 001 200	Customisable waste identification label
413 004 054	Locking ring for 80 L container

## ODOUR FILTER FOR WASTE CONTAINERS



Activated charcoal filter to magnetically capture odour molecules. To use, simply place the adhesive filter as close as possible to the source of the odour; the filter will start to work within 12 hours of application. Several filters may be required for large containers. Filter effective for 3 months.

CODE	DESCRIPTION
413 002 448	Active carbon filter for odour absorption

## POLYETHYLENE (PE) BAGS FOR SEPARATE WASTE COLLECTION



Tough polyethylene (PE) bags for separated waste collection.

CODE	DESCRIPTION	PACK
413 003 306	Polyethylene (PE) bags for 120 and 240 litre wheelie containers 90 x h 120 cm • YELLOW	1 box x 250 pcs

## BAG HOLDER TROLLEY



Sack holder trolley for separated waste collection, 3 x 100 litre sacks.  
In white painted steel, complete with 4 non-marking wheels, 2 with brake.  
Rubber bumpers.  
Easy assembly, extremely strong and manoeuvrable.

CODE	DESCRIPTION	DIMENSIONS
413 002 467	Bag holder trolley	833 x 360 x h 900 mm

## WHEELED CONTAINERS FOR SEPARATE WASTE COLLECTION WITH PEDAL OPENING



Polyethylene (PE) container: stable, strong and very manoeuvrable.  
Pedal opening system for cover.

CODE	DESCRIPTION	CAPACITY
413 003 957	Wheeled container for separate waste collection with pedal opening 380 x 500 x h 800 mm • WHITE	80 L
413 003 958	Wheeled container for separate waste collection with pedal opening 380 x 500 x h 800 mm • BLUE	80 L
413 003 959	Wheeled container for separate waste collection with pedal opening 380 x 500 x h 800 mm • GREY	80 L
413 003 960	Wheeled container for separate waste collection with pedal opening 380 x 500 x h 800 mm • GREEN	80 L
413 003 961	Wheeled container for separate waste collection with pedal opening 380 x 500 x h 800 mm • YELLOW	80 L
413 003 962	Wheeled container for separate waste collection with pedal opening 380 x 500 x h 800 mm • RED	80 L

## WASTE CONTAINER



Stainless-steel waste container. Epoxy powder-coated metal. Push-to-open stainless-steel lid. Side handles for easy movement. Galvanised internal bin with handle. ABS base.

CODE	DESCRIPTION	CAPACITY
413 004 224	Refuse container • satin stainless-steel	52 L
413 004 225	Refuse container • Black	52 L

## AUTOMATIC OPENING WASTE CONTAINER



Automatic opening stainless-steel waste container. Polished stainless-steel structure. Black ABS lid with heat sensor. Opens from all directions. Polypropylene internal bin with handle. Uses two 1.5V (type D) batteries, not included.

CODE	DESCRIPTION	CAPACITY
413 004 227	Automatic opening waste container Polished stainless steel	50 L

## TILT DOOR OPENING WASTE CONTAINER



Container made entirely of stainless steel, equipped with tilting door and removable cap to facilitate emptying operations.

CODE	DESCRIPTION	CAPACITY
413 004 615	Polished stainless steel waste container w/tilting cover	100 L

## CONTAINERS FOR SEPARATE WASTE COLLECTION IN STEEL

Stainless steel or epoxy powder coated steel containers.

Removable front for HACCP compliant use, elastic bag holder and foot pedal operated cover.

Rubber castors, practical and easy to manoeuvre.



- Wheeled pedal-operated
- Push-to-open
- Automatic opening

CODE	DESCRIPTION	CAPACITY
413 001 300	Wheeled container for separate waste collection in steel with pedal opening 480 x 420 x h 755 mm • WHITE painted	70 L
413 001 301	Wheeled container for separate waste collection in steel with pedal opening 480 x 420 x h 965 mm • WHITE painted	110 L
413 001 302	Wheeled container for separate waste collection in steel with pedal opening 480 x 420 x h 755 mm • in stainless steel	70 L
413 001 303	Wheeled container for separate waste collection in steel with pedal opening 480 x 420 x h 965 mm • in stainless steel	110 L

### CNPP CERTIFICATION ON REQUEST

CODE	DESCRIPTION	CAPACITY
413 001 304	Wheeled container for separate waste collection in steel with pedal opening 480 x 420 x h 965 mm • painted RED	110 L
413 001 305	Wheeled container for separate waste collection in steel with pedal opening 480 x 420 x h 965 mm • painted GREEN	110 L
413 001 306	Wheeled container for separate waste collection in steel with pedal opening 480 x 420 x h 965 mm • painted YELLOW	110 L
413 001 307	Wheeled container for separate waste collection in steel with pedal opening 480 x 420 x h 965 mm • painted BLUE	110 L

CODE	DESCRIPTION
413 001 200	Customisable waste identification label





## STACKABLE CONTAINERS FOR SEPARATE WASTE COLLECTION



### Wide opening cover

100% recyclable polypropylene (PP) and polyethylene (PE) containers, resistant to UV rays. Modern and compact design, large capacity, ideal for both residential and commercial waste collection, for indoor or outdoor use (dirt-resistant cover shaped to favour run-off of rain water).

CODE	DESCRIPTION	CAPACITY
413 003 939	Stackable container for separate waste collection, with wide opening cover 430 x 415 x h 510 mm • BLUE	50 L
413 003 940	Stackable container for separate waste collection, with wide opening cover 430 x 415 x h 510 mm • YELLOW	50 L
413 003 941	Stackable container for separate waste collection, with wide opening cover 430 x 415 x h 510 mm • GREEN	50 L
413 003 942	Stackable container for separate waste collection, with wide opening cover 430 x 415 x h 510 mm • ANTHRACITE	50 L
413 003 943	Stackable container for separate waste collection, with wide opening cover 430 x 415 x h 510 mm • WHITE	50 L



### Wide opening cover and front opening

100% recyclable polypropylene (PP) and polyethylene (PE) containers, resistant to UV rays. Fitted with a frontal push opening, the containers may be stacked to reduce ground surface coverage. Modern and compact design, large capacity, ideal for both residential and commercial waste collection, for indoor or outdoor use (dirt-resistant cover shaped to favour run-off of rain water).

Hatch size designed for even large waste, glass and plastic bottles. The handle built into the cover maintains full storage capacity.

CODE	DESCRIPTION	CAPACITY
413 002 468	Stackable container for separate waste collection with front opening 384 x 353 x h 420 mm • GREY	35 L
413 002 470	Stackable container for separate waste collection with front opening 384 x 353 x h 420 mm • GREEN	35 L
413 002 471	Stackable container for separate waste collection with front opening 384 x 353 x h 420 mm • WHITE	35 L
413 002 472	Stackable container for separate waste collection with front opening 384 x 353 x h 420 mm • BLUE	35 L
413 002 473	Stackable container for separate waste collection with front opening 384 x 353 x h 420 mm • YELLOW	35 L

## CARDBOARD CONTAINERS FOR WASTE MANAGEMENT STATIONS



Containers made from tough recycled cardboard with recycled PP cover; modular structure allows users to obtain their own ideal composition. Dedicated openings allow the containers to be fastened together to create a waste management station. The cover functions as a bag holder.

**Minimum total order quantity: 3 pcs (choice of quantities from the three available types)**

CODE	DESCRIPTION	CAPACITY
413 003 927	Cardboard container for waste management station • 320 x 285 x h 400 mm	15 L
413 003 928	Cardboard container for waste management station • 320 x 285 x h 500 mm	19 L
413 003 929	Cardboard container for waste management station • 320 x 285 x h 600 mm	23 L
413 003 930	Cardboard container for waste management station • 320 x 285 x h 700 mm	29 L

Cover colours: Blue - Green - Yellow - Brown - Grey



## ALUMINIUM CONTAINERS FOR WASTE MANAGEMENT STATIONS



Containers with a clean, linear design, ideal for use in public and private premises (stations, airports, shopping centres, sports grounds, offices etc.)

**Minimum total order quantity: 3 pcs (choice of quantities from the three available types)**

CODE	DESCRIPTION	CAPACITY
413 003 923	Aluminium container for waste management station • 320 x 285 x h 400 mm	15 L
413 003 924	Aluminium container for waste management station • 320 x 285 x h 500 mm	19 L
413 003 925	Aluminium container for waste management station • 320 x 285 x h 600 mm	23 L
413 003 926	Aluminium container for waste management station • 320 x 285 x h 700 mm	29 L

Cover colours: Blue – Green – Yellow – Brown - Grey

## PAINTED METAL CONTAINERS FOR SEPARATED WASTE COLLECTION



10/10 mm painted metal container. The drum has two holes for use as handles, and other holes for internal ventilation, as well as offering easy identification of the level of waste.

The container's ventilation type also makes it particularly suitable for separate waste collection.

Multiple modules can be used together to form an elegant waste management station.

The lid is easily released both for inserting the bin bag and for cleaning the inside of the container.

CODE	DESCRIPTION	CAPACITY
413 004 245	Painted metal container • 350 x 260 x h 700 mm	60 L
413 004 246	Painted metal container • 370 x 280 x h 750 mm	80 L
413 004 247	Painted metal container • 400 x 300 x h 800 mm	100 L

## WASTE MANAGEMENT STATIONS IN ALVEOLAR POLYPROPYLENE



Alveolar PP containers for separated waste collection of plastic, paper, metal, glass, organic waste and unsorted refuse.

The white drum has holes for aeration and to allow the quantity of waste contained to be easily determined; this aeration facilitates evaporation of the water contained in the organic waste, leading to reduced weight and foul odours. It is completely recyclable and ideal for offices, hospitals, schools, trade fairs, exhibitions and industry.

Resistant to impacts, water, fats and solvents.

Light, washable and long lasting.

Yellow, blue, grey, green, white and brown covers.

Adhesive labels to identify type of refuse.

CODE	DESCRIPTION	CAPACITY	PACK
413 003 057	Container for mini waste management station in alveolar PP • 300 x 400 x h 850 mm	100 L	30 pieces
413 003 350	Two-compartment container in alveolar PP 300 x 400 x h 850 mm	100 L	30 pieces

CODE	DESCRIPTION
413 003 351	Sticker for waste type

## STEEL WASTE MANAGEMENT STATION



Waste management station with an understated, linear design ideal for use in public and private indoor locations (stations, airports, shopping centres, sports facilities, offices etc.); composed of three compartments and a triangular locking cover, it is made entirely of electrogalvanised steel sheet. The build quality and quality of the components ensure functionality and durability.

CODE	DESCRIPTION	CAPACITY
413 003 919	Three-compartment waste management station for separate waste collection 620 x 360 x h 760 mm • WHITE	180 L
413 003 920	Three-compartment waste management station for separate waste collection 620 x 360 x h 760 mm • ALUMINIUM GREY	180 L



CODE	DESCRIPTION	CAPACITY
413 003 921	Four-compartment waste management station for separate waste collection 820 x 360 x h 760 mm • WHITE	240 L
413 003 922	Four-compartment waste management station for separate waste collection 820 x 360 x h 760 mm • ALUMINIUM GREY	240 L

Customisable graphics

ON REQUEST



CODE	DESCRIPTION
413 004 611	Rain cover for waste management station code 413003919 - 413003920
413 004 612	Rain cover for waste management station code 413003921 - 413003922

## 3, 4 AND 5-COMPARTMENT SEPARATE WASTE COLLECTION CONTAINER



Innovative and indispensable container. Made from brushed AISI 430 stainless steel. Complete with four removable plastic bins and casters for easy movement.

CODE	DESCRIPTION	CAPACITY
413 004 616	Satin-finish stainless-steel 3-compartment container • 450 x 360 x h 690 mm	58 L
413 004 235	Satin-finish stainless-steel 4-compartment container • 560 x 350 x h 880 mm	72 L
413 004 236	Satin-finish stainless-steel 5-compartment container • 530 x 350 x h 720 mm	64 L





## ADHESIVE LABELS FOR SEPARATED WASTE COLLECTION



Set of identification labels to be stuck to recycling waste containers. Printed on plastic coated PVC for longer life and higher resistance to atmospheric agents.

CODE	DESCRIPTION	COLOUR
413 002 449	"OTHER WASTE" adhesive label • 150 x 60 mm	ORANGE
413 002 450	"PAPER" adhesive label • 150 x 60 mm	BLUE
413 002 451	"PLASTIC" adhesive label • 150 x 60 mm	YELLOW
413 002 452	"MEDICINES" adhesive label • 150 x 60 mm	PURPLE
413 002 453	"METAL" adhesive label • 150 x 60 mm	RED
413 002 454	"COMPOSTABLE" adhesive label • 150 x 60 mm	BROWN
413 002 455	"BATTERIES" adhesive label • 150 x 60 mm	LIGHT BLUE
413 002 456	"GLASS" adhesive label • 150 x 60 mm	GREEN

## ALVEOLAR POLYPROPYLENE CONTAINERS



Strong, tough container for separate waste collection. Ideal for offices, hospitals, schools, trade fairs and other events; made from 3 mm thick alveolar polypropylene (PP), offering excellent impact resistance and chemical resistance to water, oil, fats, salt spray and some solvents. Lightweight, washable, easy-to-move material, reusable and long-lasting. The bins feature two handle holes and text indicating the specific contents. Text also on the cover, which has a 20x17 hexagonal opening. White. Fully recyclable

CODE	DESCRIPTION	CAPACITY
413 003 743	Alveolar PP containers - TONER - 260 x 360 x h 780 mm	70 L
413 003 744	Alveolar PP containers - MEDICINES - 260 x 360 x h 780 mm	70 L
413 003 745	Alveolar PP containers - MICRO WEEE - 260 x 360 x h 780 mm	70 L

Minimum total order quantity: 20 pcs (choice of quantities from the three available types)

Tough and strong container for separate waste collection of fluorescent tubes; ideal for electrical retailers, large retail outlets and SMEs. The material used is 3 mm thick alveolar polypropylene (PP), offering excellent impact resistance and chemical resistance to water, oil, fats, saline solutions and some solvents. A lightweight, washable, easy-to-move material, which is reusable and long-lasting. Text indicating the type of waste on the two walls without holes, and indications on the side walls, including a black "R" on yellow background. Polypropylene is a material which is not affected by water, and so can be washed and the walls can also be treated with solvents. The container slots into the base, making it easy to remove, but at the same time it can be weighted down internally (e.g. with a brick), allowing the container to be positioned in partially covered areas as well. Fully recyclable.

CODE	DESCRIPTION	CAPACITY	PACK
413 003 754	Alveolar PP containers - fluorescent tubes 300 x 400 x h 750 mm	48 fluorescent tubes	10 pieces

CODE	DESCRIPTION
413 003 351	Sticker for waste type

## EXPIRED MEDICINE CONTAINERS



413 002 911



413 002 912



413 002 913



413 002 914

High density polyethylene (HDPE) containers with ballast base.  
High resistance to knocks, ageing and colour fading.  
With anti-intrusion cover in robust, easy to clean methacrylate ABS.

CODE	DESCRIPTION	CAPACITY
413 002 911	Expired medicine container, rectangular base with polyethylene (PE) ballast base • 480 x 430 x h 1050 mm	90 L
413 002 912	Expired medicine container, rectangular base with metal base • 480 x 430 x h 1010 mm	90 L
413 002 913	Expired medicine container, circular base 510 x 480 x h 950 mm	105 L
413 002 914	Expired medicine container, circular base with metal base • 430 x 480 x h 1080 mm	105 L

## MEDICAL WASTE CONTAINERS



413 003 093



413 002 957



413 004 458

In the hospital/pharmaceutical sector, there is a need for plastic containers for special hazardous waste that are qualitatively superior. Special waste subject to containment can be very dangerous due to its infectious and potentially contagious nature, which is why these plastic containers for special and dangerous waste are made to dispose of these materials in complete safety. Only the best materials are used to manufacture these packages, such as polypropylene (PP), thanks to which plastic containers for special and hazardous waste can be disposed of by incineration with maximum safety.

CODE	DESCRIPTION	CAPACITY
413 003 093	Container for medical waste (sharps and other special waste) Ø 220 x h 203 mm	6.7 L
413 002 957	Container for medical waste (sharps and other special waste) 418 x 310 x 373 mm	30 L
413 004 458	Yellow polypropylene container for medical waste, ADR approved. Final closure • ADR 3H2/Y32/S approval Top dim. 418 x 310 Bottom dim. 347 x 245 h 575 mm	63 L

## CARDBOARD CONTAINER FOR INFECTIOUS WASTE - ADR APPROVED



Containers for special waste, built with corrugated cardboard of excellent quality or in polypropylene, perfectly matching the qualitative and dimensional characteristics of the prototypes approved by the BVT institute and compliant with current ADR regulations.

They have passed all the necessary tests to obtain the type approval required by current legislation on the collection and transport of hazardous health waste at infectious risk. Inside the container, there is a polyethylene bag that can be closed with the special clamp supplied. The lid is equipped with a temporary and final closure to ensure that material does not leak even in case of falls. The containers are approved for all types of transport: by land, rail, sea and air.

CODE	DESCRIPTION	CAPACITY	PACK
413 004 456	Cardboard container for infectious waste - ADR approved. With bag and clamp • 377 x 278 x h 542 mm	60 L	65 pcs
413 004 457	Cardboard container for infectious waste - ADR approved. With bag and clamp • 350 x 350 x h 650 mm	80 L	65 pcs

## STEEL CONTAINERS FOR USED OIL FILTERS



Steel container, composed of two distinct and separable stacked modules: Upper module: with hinged lid with safety rod to prevent accidental closing at 45° and 90° and upper handle, galvanised steel grid base to allow the passage of liquids, liquid collection sump on base: removable from upper module with quick coupling via steel snap-locking levers.

Square shape, vertical axis, flat base and walls. Corrosion-resistant galvanised steel structure for permanent exposure to the elements, unpainted.

Side handles for movement. Vertical adhesive text identifying the waste type on the container body. Stickers with mandatory safety signage.

CODE	DESCRIPTION	CAPACITY
413 004 231	Steel container for used oil filters • 500 x 500 x h 1000 mm	250 L



Galvanised steel container, yellow powder coated, vertical cylindrical shape, flat base. Corrosion-resistant galvanised steel for permanent exposure to the elements, with external powder coating. Standard yellow colour. Side plastic handles. Hinged opening upper cover, with chromed handle.

Locking lid with key. Adhesive text identifying the waste type on the container. Non-drip inner PE bin.

CODE	DESCRIPTION	CAPACITY
413 004 084	Steel container for used oil filters • Ø 400 x h 840 mm	100 L

## HAZARDOUS WASTE CONTAINER



Rotomoulded polyethylene (PE) container to guarantee resistance to wear, ageing and discolouration. The cover is thermoformed ABS and is fastened to the container with a triangular catch, complete with vandal-proof door. Emptying is performed with a bag of appropriate thickness to guarantee complete safety to the operator. The base is in roto-moulded polyethylene (PE), weighing 18 kg, with the possibility to add ballast.

CODE	DESCRIPTION	CAPACITY
413 003 284	Hazardous waste container • 400 x h 1050 mm	90 L

## SPRAY CAN COLLECTION CONTAINER



Approved container made of antistatic plastic for collecting empty or partially empty spray cans. Upper opening for inserting spray cans, even with the lid closed, lid with perimeter rubber gasket and locking system, integrated side ventilation for air circulation, load capacity up to 150 kg. Absorbent cloth supplied (to be placed on the bottom) for any liquid spillage and "UN 1950" signalling stickers.

CODE	DESCRIPTION	CAPACITY	TYPE APPROVAL
413 004 856	Spray can collection container 49.5 x 55.4 x h 96 cm	120 L	1H2W/X150/S...



Wheels and ventilation opening



Cover with perimeter seal



Absorbent pad supplied

## STAINLESS STEEL ASHTRAY



413 002 482 413 002 929

Stainless-steel ashtray with internal stubber grille and lock. Support foot in plastic for ground fastening (column version) and kit for wall fastening (wall version).

CODE	DESCRIPTION	CAPACITY
413 002 482	Black painted stainless steel column ashtray Ø 300 x h 1010 mm	4 L
413 002 929	Satined stainless-steel wall ashtray Ø 180 x h 645 mm	5 L



## CONTAINER FOR EXHAUSTED TONER CARTRIDGES



Roto-moulded polyethylene (PE) container to guarantee resistance to wear, ageing and discolouration. The cover is thermoformed ABS and is fastened to the container with a triangular catch, complete with vandal-proof door. Emptying is performed with a bag of appropriate thickness to guarantee complete safety to the operator. The base is in roto-moulded polyethylene (PE), weighing 18 kg, with the possibility to add ballast.

CODE	DESCRIPTION	CAPACITY
413 003 286	Container for collection of exhausted toner cartridges • 400 x h 1050 mm	90 L

## CONTAINERS FOR EXHAUSTED BATTERIES



413 003 346

Semi-cylindrical PP container with transparent front in SAN, rear and base in yellow or according to warehouse availability. Support base in synthetic impact- and acid-resistant material; upper click cover with battery introduction slot.

CODE	DESCRIPTION	CAPACITY
413 003 346	PP container for used battery collection • 180 x 90 x h 800 mm	10 L



413 002 924

High density polyethylene (HDPE) battery container with ballast base. High resistance to knocks, ageing and colour fading. With anti-intrusion cover in robust, easy to clean methacrylate ABS.

CODE	DESCRIPTION	CAPACITY
413 002 924	Polyethylene (PE) container for collection of used batteries 460 x 480 x h 740 mm	50 L

413 001 318  
413 001 320

413 002 925

Vertical battery container with flat bottom. Made in black painted steel with bronze band. Upper hinged cover with safety lock. Shaped inlet opening.

CODE	DESCRIPTION	CAPACITY
413 001 318	Enamelled steel container for collection of used batteries • Ø 220 x h 400 mm	16 L
413 002 925	Enamelled steel container for collection of used batteries • Ø 420 x h 800 mm	100 L
CODE	DESCRIPTION	
413 001 320	Support post with anchoring base for code 413 001 318	

## CONTAINER FOR MICRO WEEE COLLECTION



Roto-moulded polyethylene (PE) container to guarantee resistance to wear, ageing and discolouration. The cover is thermoformed ABS and is fastened to the container with a triangular catch, complete with vandal-proof door.

Emptying is performed with a bag of appropriate thickness to guarantee complete safety to the operator.

The base is in roto-moulded polyethylene (PE), weighing 18 kg, with the possibility to add ballast.

CODE	DESCRIPTION	CAPACITY
413 003 285	Micro WEEE collection container • 400 x h 1050 mm	90 L

## SOLID MUNICIPAL WASTE BINS



413 001 358 - 413 001 359

Injection-moulded high density polyethylene (HDPE) bins, resistant to decay, frost, heat and chemicals.

With galvanized metal parts, solid rubber quiet-running wheels and grip handles for easy handling.

Suitable for all equipment and systems fitted with DIN couplings.

EN 840 compliant.

CODE	DESCRIPTION	CAPACITY
413 001 358	Bin for SUW collection • 1370 x 850 x h 1250 mm FLAT COVER	660 L
413 001 359	Bin for SUW collection • 1370 x 1115 x h 1470 mm FLAT COVER	1100 L







# PRODUCTS FOR LOGISTICS AND HANDLING

14 LOGISTICS AND DRUM AND CARGO PALLET HANDLING EQUIPMENT ..... page 264



## DRUM-HANDLERS

Drum handlers represent the fastest and most economical system for managing drums in working areas. They are made entirely of painted steel and are equipped with 2 fixed wheels and 2 pivoting wheels to facilitate their movement.

### MOBILE DRUM STANDS



414 001 361

414 001 362

- Mobile drum stand for 210 L drums
- Tilts drums from vertical to horizontal resting position
- Two fixed wheels and two castors for mobility
- Height of drum from ground: 330 mm
- Max. capacity: 220 Kg

CODE	DESCRIPTION
414 001 361	Mobile drum stand
414 001 362	Mobile drum stand with drum rollers

## DRUM TROLLEYS

### THREE-WHEEL DRUM TROLLEY FOR 200 L METAL DRUMS



- 2 x Ø 260 mm solid rubber wheels and 1 castor with brake
- Ergonomic handgrip
- Sliding clip secures drum firmly
- Capacity: 400 Kg
- Weight: 20 Kg

CODE	DESCRIPTION
414 001 365	Three-wheel drum trolley

### TWO-WHEEL DRUM TROLLEY FOR 200 L METAL OR POLYETHYLENE (PE) DRUMS



- 260 mm Ø solid rubber wheels
- Capacity: 400 Kg
- Weight: 23 Kg

CODE	DESCRIPTION
414 001 366	Two-wheel drum trolley

**CAGES FOR 50 LITRE GAS CYLINDER HANDLING**



Galvanized steel cage for safe gas cylinder handling and transport. Handling can be done with forklift truck or crane, as the cage is equipped with both fork passage and anchor eyelets. A fixing and protection bracket allows the cylinders to be locked, preventing them from falling during handling. CE mark.

CODE	DESCRIPTION
414 004 814	Cage for handling 4 x 50 litre gas cylinders 806 x 650 x h 1115 mm
414 004 815	Cage for handling 8 x 50 litre gas cylinders 806 x 1170 x h 1115 mm
414 004 816	Cage for handling 12 x 50 litre gas cylinders 1030 x 805 x h 1225 mm



**HYDRAULIC DRUM FORKLIFT - STANDARD CAPACITY**



- For standard 200 L drums
- Minimum effort thanks to the manual hydraulic pump
- Holding jaw on upper edge
- With two large diameter fixed wheels and 1 castor
- Max. lifting height 245 mm
- Dimensions: 800 x 820 x h 1050 mm
- Internal wheelbase 630 mm

CODE	DESCRIPTION	CAPACITY
414 001 430	Hydraulic drum forklift - standard capacity	250 Kg

Pictures indicated in this catalogue are representative and not binding for the supplier in terms of layout and colours. They may be subject to changes by the supplier without prior notice.

**PORTABLE DRUM FORKLIFT**



- Lifts, transports, rotates and drains standard 200 L metal drums
- Safe drum grip by steel sheet drum holder with safety lock
- Max. height from ground of horizontal drum: 450 mm
- Double manual assembly
- With two large diameter fixed wheels and 1 castor

CODE	DESCRIPTION	CAPACITY
414 001 433	Portable drum forklift	365 Kg



**DRUM DOLLIES**



414 001 367



414 001 368

- Drum dolly with 4 castors
- Weight: 5 Kg

CODE	DESCRIPTION
414 001 367	Drum dolly • Capacity 300 Kg
414 001 368	Drum dolly • Capacity 400 Kg

**JERRYCAN TRANSFER STAND**



Stainless steel stand, with tank fastening system. It facilitates pouring of liquid contained in the tanks, also suitable for pouring of acidic and alkaline liquid substances.

CODE	DESCRIPTION
414 004 857	Transfer stand for 30 litre tanks • 67 x 39 x h 74 cm
414 004 858	Transfer stand for 60 litre tanks • 67 x 47 x h 82 cm



Pictures indicated in this catalogue are representative and not binding for the supplier in terms of layout and colours. They may be subject to changes by the supplier without prior notice.

**RIMMED DRUM HANDLING TROLLEY**



Trolley with accessory for moving rimmed steel or plastic drums:

**Suitable for movement and handling of drums with the following specifications:**

- Drum diameter between 36 and 71 cm
- Drum height between 79 and 104 cm
- Steel drums from 114 - 210 litres
- Steel safety overpack of 320 litres
- Rimmed plastic drums
- Cardboard drums with rim sufficient to accommodate the attachment hook

**The trolley allows:**

- Easy movement of the drum
- Emptying the drum by placing it in a horizontal position
- Passing safely through narrow sections thanks to the "U" profile which protects the hands
- Loading and unloading the drums from the pallets

**Trolley characteristics**

- The trolley is self supporting, bearing all the weight of the drum without the need for operator intervention.
- The hook assists gripping and releasing the drum
- The "U"-shaped handle protects the hands
- The 20 cm wheels support the weight and facilitate movement

CODE	DESCRIPTION	CAPACITY
414 004 123	Trolley for moving rimmed steel or plastic drums	454 Kg

**NON-RIMMED DRUM HANDLING TROLLEY**



Trolley with accessory for moving rimmed or non-rimmed steel or plastic drums:

**Suitable for movement and handling of drums with the following specifications:**

- Drum diameter between 36 and 71 cm
- Drum height between 79 and 104 cm
- Steel drums from 114 - 210 litres
- Steel safety overpack of 320 litres
- Rimmed plastic drums
- Cardboard drums with rim sufficient to accommodate the attachment hook

**The optional "belt" included in the price allows movement of:**

- Non-rimmed drums
- Smaller drums with height below 78.7 cm
- Drums up to 61 cm in diameter

**The trolley allows:**

- Easy movement of the drum
- Emptying the drum by placing it in a horizontal position
- Passing safely through narrow sections thanks to the "U" profile which protects the hands
- Loading and unloading the drums from the pallets

**Trolley characteristics**

- The trolley is self supporting, bearing all the weight of the drum without the need for operator intervention.
- The hook assists gripping and releasing the drum
- The "U"-shaped handle protects the hands
- The 20 cm wheels support the weight and facilitate movement

CODE	DESCRIPTION	CAPACITY
414 004 124	Trolley for moving rimmed and non-rimmed steel or plastic drums	454 kg

Pictures indicated in this catalogue are representative and not binding for the supplier in terms of layout and colours. They may be subject to changes by the supplier without prior notice.



## FORKLIFT DRUM HANDLER ATTACHMENTS

The attachments are certified compliant with the Machinery Directive 2006/42/EC.

### FORK HOOK WITH TWO FORK OPENINGS



- Double forklift sleeve attachment c/w swivel & hook
- This model slides on to the truck fork. Turn the T-screw to secure it to the fork
- Capacity: 2500 Kg
- Fork section: 150 x 70 mm

CODE	DESCRIPTION
414 001 372	Fork hook with two fork openings

## GAS CYLINDER HAND TRUCKS

The whole range of gas cylinder hand trucks is certified compliant with the Machinery Directive 2006/42/EC.

### HAND TRUCK FOR 1 X 10, 20, 30, 40, 50 LITRE GAS CYLINDERS



- Dimensions: 660 x 600 x h 1360 mm
- Rubber covered wheels Ø 200 mm
- Cylinder diameter: 140 - 250 mm

CODE	DESCRIPTION
414 003 779	Hand truck for 1 x 10, 20, 30, 40, 50 litre gas cylinders

### HAND TRUCK FOR 2 X 40/50 LITRE GAS CYLINDERS



- Dimensions: 700 x h 1380 mm
- Rubber covered wheels Ø 400 mm

CODE	DESCRIPTION
414 003 812	Hand truck for 2 x 40/50 litre gas cylinders

 AIRBANK EXCLUSIVE

**MORSE** 

## BELOW-THE-HOOK DRUM LIFTER

These drum lifters are suitable for picking up, lifting and moving various types of drums (steel or PE) in total safety using a hook. All products are certified compliant with the Machinery Directive 2006/42/EC, as required by legislation.

### STEEL VERTI-KARRIER DRUM LIFTER FOR RIMMED STEEL DRUMS



- Suitable for grabbing, lifting, handling and placing 200 litre drums
- It automatically grabs the drum and the grip will not disconnect until drum has been fully placed down
- Time saving without dangerous handling
- Shipping dimensions: 790 x 530 x h 230 mm

CODE	DESCRIPTION	CAPACITY
414 001 377	Steel verti-karrier drum lifter for rimmed drums	454 Kg

### STEEL VERTI-KARRIER DRUM LIFTER FOR PLACING 200 OR 320 L DRUMS INTO OVERPACKS



- Allows you to place a 200 litre drum quickly into an overpack or salvage 320 litre drum
- The narrow profile enables it to lower the drum completely into an overpack drum
- Shipping dimensions: 508 x 228 x h 432 mm

CODE	DESCRIPTION	CAPACITY
414 001 380	Steel verti-karrier drum lifter for placing drums into overpacks	454 Kg

### STEEL VERTI-KARRIER DRUM LIFTERS FOR RIMMED DRUMS



- Automatically grips various closed head drums under the rim
- Suitable for moving and handling polyethylene (PE), steel and cardboard drums with underrim diameter from 457 to 660 mm and polyethylene (PE) drums from 110 to 200 L
- Shipping dimensions: 508 x 228 x h 432 mm

CODE	DESCRIPTION	CAPACITY
414 001 381	Steel verti-karrier drum lifter for rimmed drums	454 Kg
414 001 383	AISI 304 stainless-steel verti-karrier drum lifter for rimmed drums	454 Kg

### VERTICAL DRUM HANDLER ATTACHMENT



- Can be used with the hook slung under a hoist or crane for lifting and handling of heavy drums
- Equipped with a steel lifting ring
- Suitable for 200 L steel drums of 860 to 920 mm height
- Shipping dimensions: 510 x 130 x h 100 mm

CODE	DESCRIPTION	CAPACITY
414 001 384	Steel vertical drum handler attachment	454 Kg

Pictures indicated in this catalogue are representative and not binding for the supplier in terms of layout and colours. They may be subject to changes by the supplier without prior notice.

**STEEL STAND FOR VERTICAL LIFTING OF POLYETHYLENE (PE), STEEL OR CARDBOARD DRUMS**



- To be used for transport of 200 litre drums in upright position
- Safely holds drums thanks to the ratchet mechanism
- For moving steel, polyethylene (PE) or cardboard drums
- Drum diameter: from 558 to 596 mm
- Drum height: from 584 to 965 mm
- Shipping dimensions: 710 x 480 x h 760 mm

CODE	DESCRIPTION	CAPACITY
414 001 387	Steel stand for vertical lifting of polyethylene (PE) drums drums	454 Kg

\*Compatible accessories: code 414 001 405 - 406 (see page 272)

**STEEL STAND FOR LIFTING AND TILTING DRUMS**



Three-piece drum holder installed on drum rotator code 414 001 389

- Suitable for handling 200 L steel drums
- Manual control of the tilt angle for fast dumping or controlled dispensing operations
- The tilt angle block holds the drum in the vertical position for transport or horizontal position for pouring operations
- Shipping dimensions: 991 x 686 x h 229 mm

CODE	DESCRIPTION	CAPACITY
414 001 388	Steel stand for lifting and tilting drums, with chain grip system	363 Kg
414 001 389	Steel stand with three-piece drum holder for lifting and tilting drums	363 Kg
414 001 391*	AISI 304 stainless-steel stand for lifting and tilting drums, with chain grip system	363 Kg

\*Compatible accessories: code 414 003 216 - 217 (see page 272)



Gripper system with jack and chain



Drum holder

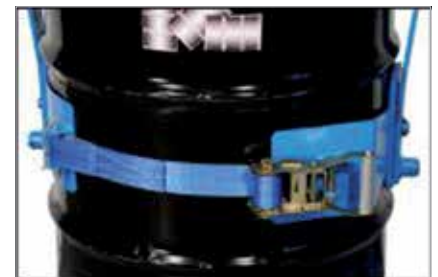

Belt grip system

Pictures indicated in this catalogue are representative and not binding for the supplier in terms of layout and colours. They may be subject to changes by the supplier without prior notice.

# BELOW-HOOK DRUM ROTATOR WITH MANUAL TILT CONTROL

 AIRBANK EXCLUSIVE



The drum lifters/rotators allow tilting of the drum (steel or polyethylene (PE)) to perform decanting operations in maximum safety by allowing manual tilt control. All products are certified compliant with the Machinery Directive 2006/42/EC, as required by legislation.

## STEEL DRUM ROTATORS - STANDARD CAPACITY



- The pull chain control allows a rotation ratio of 30:1
- Equipped with a traction chain pulley to control pouring at elevated heights
- Shipping dimensions: 991 x 864 x h 254 mm

CODE	DESCRIPTION	CAPACITY
414 001 392*	Steel drum rotator - standard capacity - chain grip system	363 Kg
414 001 393	Steel drum rotator with three-piece drum holder - standard capacity Drum holder	363 Kg

Three-piece drum holder installed on drum rotator code 414 001 393



\*Compatible accessories: code 414 003 216 - 217 (see page 272)

## STEEL DRUM ROTATOR - MEDIUM CAPACITY



- Improved tilt control with 60:1 ratio gear and sprocket drive
- The standard models are equipped with a traction chain pulley to control pouring at elevated heights
- Shipping dimensions: 990 x 864 x h 254 mm

CODE	DESCRIPTION	CAPACITY
414 001 396*	Steel drum rotator - medium capacity - drum holder	680 Kg
414 001 397	Steel drum rotator with three-piece drum holder - medium capacity chain grip system	680 Kg

Three-piece drum holder installed on drum rotator code 414 001 397



\*Compatible accessories: code 414 003 216 - 217 (see page 272)

Pictures indicated in this catalogue are representative and not binding for the supplier in terms of layout and colours. They may be subject to changes by the supplier without prior notice.



### STEEL DRUM ROTATORS - HIGH CAPACITY



- Worm gear speed reducer with 60:1 ratio for extra load capacity
- Ideal for handling 200 L steel drums
- Pulley with drag chain and 330 mm ring
- Shipping dimensions: 1067 x 1067 x h 381 mm

CODE	DESCRIPTION	CAPACITY
414 001 400	Steel drum rotator - high capacity - chain grip system	909 Kg

### POWER TILT STEEL DRUM ROTATOR



- 360° electric drum rotation in either direction
- Remote-controlled tilt control
- Pneumatic or electric motor
- For handling 200 L steel drums
- Shipping dimensions: 1143 x 610 x h 1016 mm

CODE	DESCRIPTION	CAPACITY
414 001 403*	Power tilt steel drum rotator - 230 V motor	680 Kg
414 001 404*	Power tilt steel drum rotator - pneumatic motor	680 Kg

\*Compatible accessories: code 414 003 216 - 217

### ACCESSORIES FOR DRUM CARRIERS AND ROTATORS



- Diameter adaptors to handle smaller drums
- Quickly inserted into and removed from normal and anti-spark drum carriers

CODE	DESCRIPTION
414 001 405	Adaptor for 60 L steel drums
414 001 406	Adaptor for 110 L steel drums

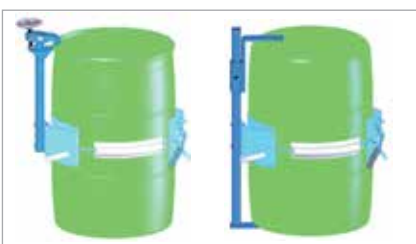

414 003 217

414 003 216

- Suitable for preventing sliding of drums from stands
- Necessary for movement of polyethylene (PE) and cardboard drums

CODE	DESCRIPTION
414 003 216	Stand for non-rimmed polyethylene (PE) or cardboard drums
414 003 217	Stand for rimmed polyethylene (PE) or cardboard drums

# FORKLIFT ATTACHMENTS FOR LIFTING, MOVING AND POURING DRUMS

 AIRBANK EXCLUSIVE



This equipment is designed to move and handle all types of drums in complete safety and to facilitate pouring. The Karriers are easily hooked onto forklift trucks. All products are certified compliant with the Machinery Directive 2006/42/EC.

## STEEL DRUM KARRIER - STANDARD CAPACITY



- Rotation ratio 30:1
- Complete with pulley and chain for manual tilt control by the forklift driver
- Suitable for handling 200 L steel drums
- The forklift karrier can also be used for handling drums with smaller dimensions by adding a reducer
- Fork pocket opening dimensions: 16.5 x h 6.35 cm
- Fork opening distance: 622 mm

CODE	DESCRIPTION	CAPACITY
414 001 407*	Steel drum karrier - standard capacity - chain grip system	360 Kg
414 001 409	Steel karrier with three-piece drum holder - standard capacity Drum holder	360 Kg

Three-piece drum holder installed on drum rotator code 414 001 409



**\*Compatible accessories: code 414 003 216 - 217 (see page 272)**

Pictures indicated in this catalogue are representative and not binding for the supplier in terms of layout and colours. They may be subject to changes by the supplier without prior notice.

**STEEL DRUM KARRIER - HIGH CAPACITY**



- To obtain improved load and better tilt control, the heavy-duty models are equipped with an additional 2:1 gear-wheel, to provide a rotation ratio of 60:1
- The standard models are equipped with traction chain and pulley for tilt control from the driving seat of the forklift
- Ideal for handling 200 L steel drums
- The forklift karrier can also be used for handling drums with smaller dimensions by adding a reducer
- Fork pocket opening dimensions: 16.5 x h 6.35 cm
- Fork opening distance: 622 mm
- Shipping dimensions: 1016 x 737 x h 610 mm

CODE	DESCRIPTION	CAPACITY
414 001 410*	Steel drum karrier - high capacity	680 Kg
414 001 412	Steel karrier with three-piece drum holder - high capacity	680 Kg
414 001 413	Steel drum karrier for non-rimmed polyethylene (PE) drums - high capacity	680 Kg

Three-piece drum holder installed on drum rotator code 414 001 412



\*Compatible accessories: code 414 003 216 - 217 (see page 272)

**ACCESSORIES FOR VERTICAL MOVEMENT OF DRUMS WITH FORKLIFTS**



414 001 415

- Suitable for handling of rimmed steel or polyethylene (PE) drums
- Ideal for grasping, lifting and handling drums while remaining at the controls of the forklift
- Easily installed on the fork without the need for tools
- The compact steel jaw grasps the rim of the barrel solidly, ensuring safe handling

CODE	DESCRIPTION	CAPACITY
414 001 415	Accessory for vertical movement of drums with forklifts	360 Kg
414 001 416		680 Kg



414 001 416

Pictures indicated in this catalogue are representative and not binding for the supplier in terms of layout and colours. They may be subject to changes by the supplier without prior notice.

## DRUM LIFTERS



414 001 417



414 001 418

- Simple system for handling 200 L steel drums
- Gripping and releasing are controlled directly from the forklift driver's seat

CODE	DESCRIPTION	CAPACITY
414 001 417	1 x 200 L drum clamp Fork section 140 x 50 mm	680 Kg
414 001 418	2 x 200 L drum clamp Fork section 150 x 55 mm	2 x 450 kg



414 001 419

- Handles 200 L steel or plastic drums
- Ideal for moving drum from upright to horizontal position, or vice versa
- Can be used to rack or move drums or load trucks
- Automatic structure allows operator to manage drum handling from the forklift driving seat

CODE	DESCRIPTION	CAPACITY
414 001 419	1 x 200 L drum clamp Fork section 150 x 60 mm	400 Kg



Pictures indicated in this catalogue are representative and not binding for the supplier in terms of layout and colours. They may be subject to changes by the supplier without prior notice.



## DRUM PALLETIZERS

Equipment for simply and effectively lifting, transporting and positioning drums during pallet loading and unloading operations. All products are certified compliant with the Machinery Directive 2006/42/EC.

### MANUAL DRUM PALLETIZER

 AIRBANK EXCLUSIVE

**MORSE** 



- Manual drum palletizer for 200 L steel drums
- Angular shape and double grip allow perfect balance of the drum when it is picked up from the pallet

CODE	DESCRIPTION	CAPACITY
414 001 838	Manual drum palletizer	360 Kg

### DRUM PALLETIZER WITH MANUAL TILT

 AIRBANK EXCLUSIVE

**MORSE** 



- Suitable for lifting, transporting and pouring heavy drums
- It is possible to lock the drum in the vertical position to avoid accidental spills
- Suitable for 200 L steel drums
- Raising height 508 mm

CODE	DESCRIPTION	CAPACITY
414 001 432*	Manual-tilt drum palletizer	272 Kg

\*Compatible accessories: code 414 003 216 - 217 (see page 272)

### HYDRAULIC DRUM PALLETIZER HIGH CAPACITY

 AIRBANK EXCLUSIVE

**MORSE** 



- Suitable for positioning drums on pallets
- Automatic engagement and release of drums
- Raises drums up to 483 mm above floor level

CODE	DESCRIPTION	CAPACITY
414 001 431	Hydraulic drum palletizer - high capacity	454 Kg

**FRONT HYDRAULIC DRUM-LIFT PALLETIZER**



Hydraulic front drum lift palletizer for steel drums, powder coated for heavy loads, 210 litre steel drums. These trolleys are designed to load and unload drums on and off pallets and/or drum sumps. They allow a single operator to pick up and transport full or empty steel drums with minimal effort and in total safety. They are easy to position and have a hydraulic gripper that grips and lifts the drum from the edge, which means that the operator must not manoeuvre or touch the drum by hand. A touch-sensitive release valve lowers the drum slowly and safely.

CODE	DESCRIPTION	CAPACITY
414 004 923	Front hydraulic drum-lift palletizer 2 fixed wheels and 2 wheels with brake 980 x 820 x h 1200 mm • Max. lifting height 280 mm Distance between forks 800 mm	250 Kg



Pictures indicated in this catalogue are representative and not binding for the supplier in terms of layout and colours. They may be subject to changes by the supplier without prior notice.

## DRUM ROTATORS



Machine designed to guarantee the homogeneity of the drum contents by mixing ingredients which might have settled to the bottom of the container. All products are certified compliant with the Machinery Directive 2006/42/EC.

### STATIONARY DRUM ROTATOR



- For moving steel drums (dia. from 152 mm to 660 mm and 1016 mm maximum height)
- Liquid load capacity: 450 Kg
- Dry load capacity: 180 Kg
- Just load the drum vertically on the platform, tilt it with the electrical system and activate mixing
- Models supplied with safety interlock and fence.

CODE	DESCRIPTION	RPM
414 001 434	Stationary drum rotator - 1HP single phase - 220 V	5 - 20
414 001 435	Stationary drum rotator - 1HP three-phase - 380 V	5 - 20

### COMPACT DRUM ROTATOR



- For moving steel drums (dia. from 152 mm to 711 mm and 1016 mm maximum height)
- Liquid load capacity: 450 Kg

CODE	DESCRIPTION	RPM
414 001 439*	Compact drum rotator - 220 V	20

\* Models supplied with safety interlock and fence.

## DRUM RACKERS



- Ideal for lifting, tilting, pouring and racking heavy drums
- Suitable for positioning drums on shelves up to 1820 mm in height
- Extremely strong lifting components
- Suitable for handling 200 L steel drums
- Capacity with full drum: 363 Kg
- Shipping dimensions: 1829 x 1270 x h 1397 mm

CODE	DESCRIPTION	CAPACITY
414 001 424	Drum racker with electric lift and tilt - 1 HP - 220 V	363 Kg
414 001 425	Drum racker with pneumatic lift and tilt	363 Kg
414 001 426	Drum racker with electric lift and manual tilt - 1 HP - 220 V	363 Kg
414 001 427	Drum racker with manual lift and tilt	363 Kg

Pictures indicated in this catalogue are representative and not binding for the supplier in terms of layout and colours. They may be subject to changes by the supplier without prior notice.

# DRUM TUMBLERS



All products are certified compliant with the Machinery Directive 2006/42/EC.

## "CORNER OVER CORNER" MIXING DRUM TUMBLERS



414 001 450 - 451

- Electrical tilt system for lifting the drum from the vertical to the required rotation position
- Ideal both for steel and polyethylene (PE) drums with Ø from 457 to 596 mm and height from 736 to 939 mm
- Capacity: 363 Kg

CODE	DESCRIPTION	RPM
414 001 450*	"Corner Over Corner" mixing drum tumbler 2 HP - Single phase - 220 V	4 - 16
414 001 451*	"Corner Over Corner" mixing drum tumbler 2 HP - Three-phase - 380 V	4 - 16

\* Models supplied with safety interlock and fence.

## CAN TUMBLERS

- Thorough "corner over corner" mixing action
- Ideal for containers and buckets from 4 to 19 L (with Ø max 317 mm and height from 120 to 420 mm)
- Capacity: 45 kg per container

**\*Version for 1 container:**



CODE	DESCRIPTION	RPM
414 001 465	Single-container tumbler - ¼ HP • Single phase with timer - 220 V	19
414 001 466	Single-container tumbler - ¼ HP • Three-phase - 380 V	19
414 001 467	Single-container tumbler - Pneumatic	23

**\*Version for 2 containers:**



CODE	DESCRIPTION	RPM
414 001 470	Two-container tumbler - ¼ HP • Single phase with timer - 220 V	19
414 001 471	Two-container tumbler - ¼ HP • Three-phase - 380 V	19
414 001 472	Two-container tumbler - Pneumatic	23

\* Available with mesh side protection and control panel

Pictures indicated in this catalogue are representative and not binding for the supplier in terms of layout and colours. They may be subject to changes by the supplier without prior notice.









# PRODUCTS FOR EMERGENCIES

15 EMERGENCY AND CIVIL PROTECTION EQUIPMENT..... page 282

16 SPECIAL EQUIPMENT..... page 287

### PLUGS

The plugs can be used to obstruct, bypass and control ducts with both air and water. The plugs are a quick and effective solution to many situations. They can be used, for instance, in emergency circumstances to block manhole covers and pipes, thus preventing hazardous liquids from leaking and polluting the environment.

#### FEATURES

- The inflation pressure provides excellent surface adhesion with the pipe to be blocked, hindering any movement
- The plugs are designed to resist backpressure up to 1.0 Bar
- The bypass series plugs can be used for air, water and vacuum controls
- The plugs are available in a wide variety of diameters
- The high quality of the product with rubber reinforcement guarantees a long and durable life
- The raised profile on the rubber allows a perfect seal between the plug and the pipe

#### PLUGS



CODE	DESCRIPTION	PRESSURE OF INFLATION REQUIRED	DEFLATED PLUG DIMENSION	WEIGHT	MEASUREMENT OF RING THREAD	INFLATION VALVE (THREAD DIM.)
415 001 520	Plug • Ø from 40 to 70 mm	2.5 bars	Ø 35 x 195 mm	0.3 Kg	6	R 1/4"
415 001 521	Plug • Ø from 70 to 150 mm	2.5 bars	Ø 68 x 335 mm	0.6 Kg	6	R 1/4"
415 001 522	Plug • Ø from 100 to 200 mm	2.5 bars	Ø 92 x 535 mm	1.1 Kg	6	R 1/4"
415 001 523	Plug • Ø from 150 to 200 mm	2.5 bars	Ø 142 x 385 mm	1.8 Kg	8	R 1/4"
415 001 524	Plug • Ø from 150 to 300 mm	2.5 bars	Ø 142 x 575 mm	1.9 Kg	8	R 1/4"
415 001 525	Plug • Ø from 200 to 400 mm	2.5 bars	Ø 192 x 635 mm	3.0 Kg	8	R 1/4"
415 001 526	Plug • Ø from 300 to 525 mm	2.5 bars	Ø 272 x 675 mm	6.0 Kg	8	R 1/4"
415 001 527	Plug • Ø from 350 to 600 mm	2.5 bars	Ø 322 x 865 mm	8.4 Kg	10	R 1/4"
415 001 528	Plug • Ø from 375 to 750 mm	2.5 bars	Ø 342 x 1085 mm	10.9 Kg	10	R 1/4"
415 001 529	Plug • Ø from 500 to 800 mm	2.5 bars	Ø 472 x 1185 mm	17.3 Kg	10	R 1/4"
415 001 530	Plug • Ø from 500 to 1000 mm	1.5 bars	Ø 472 x 1185 mm	17.3 Kg	10	R 1/4"
415 001 531	Plug • Ø from 600 to 1200 mm	1.5 bars	Ø 574 x 1500 mm	39.0 Kg	10	2 x R 3/8"
415 001 532	Plug • Ø from 750 to 1500 mm	1.0 bars	Ø 600 x 2300 mm	65.0 Kg	10	2 x R 1/4"



**PLUGS WITH BYPASS**

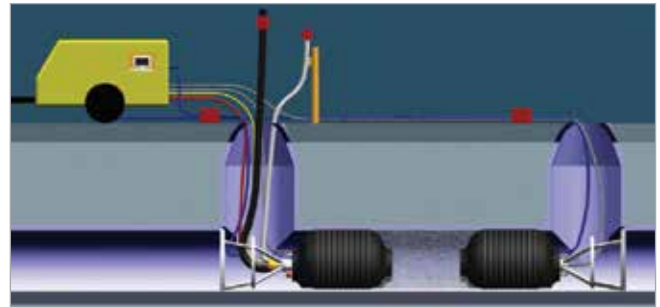

CODE	DESCRIPTION	PRESSURE OF INFLATION REQUIRED	DEFLATED PLUG DIMENSION	WEIGHT	MEASUREMENT OF RING THREAD	INFLATION VALVE (THREAD DIM.)	MEASUREMENT Ø BYPASS
415 001 533	Bypass plug • Ø from 70 to 150 mm	2.5 bars	Ø 68 x 350 mm	1.7 Kg	6	R 1/4"	1/2"
415 001 534	Bypass plug • Ø from 100 to 200 mm	2.5 bars	Ø 92 x 550 mm	2.6 Kg	6	R 1/4"	1"
415 001 535	Bypass plug • Ø from 150 to 200 mm	2.5 bars	Ø 142 x 420 mm	3.2 Kg	8	R 1/4"	1"
415 001 536	Bypass plug • Ø from 150 to 300 mm	2.5 bars	Ø 142 x 590 mm	4.4 Kg	8	R 1/4"	1"
415 001 537	Bypass plug • Ø from 200 to 400 mm	2.5 bars	Ø 192 x 635 mm	6.3 Kg	8	R 1/4"	2"
415 001 538	Bypass plug • Ø from 300 to 525 mm	2.5 bars	Ø 272 x 675 mm	11.9 Kg	8	R 1/4"	2"
415 001 539	Bypass plug • Ø from 350 to 600 mm	2.5 bars	Ø 322 x 865 mm	16.6 Kg	10	R 1/4"	2"
415 001 540	Bypass plug • Ø from 375 to 750 mm	2.5 bars	Ø 342 x 1085 mm	19.7 Kg	10	R 1/4"	2"
415 001 541	Bypass plug • Ø from 500 to 800 mm	2.5 bars	Ø 472 x 1185 mm	31.3 Kg	10	R 1/4"	2"
415 001 542	Bypass plug • Ø from 500 to 1000 mm	1.5 bars	Ø 472 x 1185 mm	31.3 Kg	10	R 1/4"	2"
415 001 543	Bypass plug • Ø from 600 to 1200 mm	1.5 bars	Ø 574 x 1500 mm	46.0 Kg	10	2 x R 3/8"	4"
415 001 544	Bypass plug • Ø from 750 to 1500 mm	1.0 bars	Ø 600 x 2300 mm	75.0 Kg	10	2 x R 1/4"	4"

**ACCESSORIES FOR PLUGS**



Protective circular sleeve apply where impurities may damage the plug

CODE	DESCRIPTION
415 001 545	Protective sleeve for plugs Ø from 350 to 600 mm
415 001 546	Protective sleeve for plugs Ø from 375 to 750 mm
415 001 547	Protective sleeve for plugs Ø from 500 to 1000 mm
415 001 548	Protective sleeve for plugs Ø from 600 to 1200 mm
415 001 549	Protective sleeve for plugs Ø from 750 to 1500 mm



Compressed air cylinder



Pressure regulator



Control panel

CODE	DESCRIPTION
415 001 550	Compressed air cylinder 300 bar 6 L
415 001 551	Pressure reducer from 300 / 200 bar to 12 bar
415 001 552	Single controller from 12 Bar to 2.5 Bar
415 001 553	Single controller from 12 Bar to 1.5 Bar
415 001 554	Single controller from 12 Bar to 1.0 Bar
415 001 555	Inflating hose, 10 m, RED
415 001 556	Inflating hose: 10 m, BLUE
415 001 557	Inflating hose, 10 m, YELLOW



Inflating hoses



## HIGH-PRESSURE AIR BAGS, 8 BAR



These air bags are designed for lifting heavy loads in emergency situations such as civil protection and firefighting, and for use by engineering and maintenance companies in situations such as extracting entrapped persons, lifting vehicles damaged in accidents, adjusting the height of machinery etc.

These lifting devices are available in a wide range of formats (from 1 to 65 tonnes), offering lifting heights of up to 500 mm, and comply with NF EN 13731 which guarantees safety during these kinds of operations.

Air bags offer numerous advantages: their non-slip finish ensures good adherence to the surface of the object to be lifted, and allows them to be stacked. The inflation pressure is 8 bar. The air bags are fitted with a self-sealing valve which stops them from deflating.

CODE	DESCRIPTION	LIFTING CAPACITY	MAX. LIFTING CAPACITY
415 004 300	High-pressure air bags, 8 bar • 150 x 150 x h 25 mm	1000 Kg	90 mm
415 004 301	High-pressure air bags, 8 bar • 200 x 200 x h 25 mm	3000 Kg	115 mm
415 004 302	High-pressure air bags, 8 bar • 300 x 300 x h 25 mm	6000 Kg	175 mm
415 004 303	High-pressure air bags, 8 bar • 380 x 380 x h 25 mm	10000 Kg	220 mm
415 004 304	High-pressure air bags, 8 bar • 420 x 420 x h 25 mm	14000 Kg	245 mm
415 004 305	High-pressure air bags, 8 bar • 510 x 510 x h 25 mm	19000 Kg	295 mm
415 004 306	High-pressure air bags, 8 bar • 560 x 560 x h 25 mm	24000 Kg	320 mm
415 004 307	High-pressure air bags, 8 bar • 1000 x 320 x h 25 mm	24000 Kg	215 mm
415 004 308	High-pressure air bags, 8 bar • 620 x 620 x h 25 mm	30000 Kg	345 mm
415 004 309	High-pressure air bags, 8 bar • 750 x 750 x h 25 mm	43000 Kg	410 mm
415 004 310	High-pressure air bags, 8 bar • 840 x 840 x h 25 mm	54000 Kg	465 mm
415 004 311	High-pressure air bags, 8 bar • 920 x 920 x h 25 mm	65000 Kg	515 mm



**ACCESSORIES FOR AIR BAGS**



CODE	DESCRIPTION
415 004 312	One-way control panel, 1/4" 8bar
415 004 313	Two-way control panel, 1/4" 8bar
415 004 314	Inflating hose, 5 m, RED
415 004 315	Inflating hose, 10 m, RED
415 004 316	Inflating hose, 5 m, BLUE
415 004 317	Inflating hose, 10 m, BLUE
415 004 318	Inflating hose, 5 m, YELLOW
415 004 319	Inflating hose, 10 m, YELLOW
415 004 320	200 bar / 10 bar pressure regulator

**MEDIUM-PRESSURE AIR BAGS, 1 BAR**



They are ideally suited for rescuing persons trapped under a vehicle in road accidents, plane crashes, or collapsed tunnels, bridges and formworks, namely in situations where conventional rescue methods cannot be employed or would require too much preparation. This type of air bags works well even on soft, uneven or snow- and ice-covered terrain.

**FEATURES**

- Made of a combination of materials that provides a high level of safety during use
- The base and the top of the bag are textile-reinforced rubber, which provides good puncture resistance
- The inflatable part is made of polyamide fabric with a safety factor of 3-4 times the operating pressure (operating pressure / burst pressure)



CODE	DESCRIPTION	THICKNESS	MAX. LIFTING HEIGHT	LIFTING CAPACITY
415 001 578	Kit with 2 air bags medium pressure, 1 bar Ø 610 mm	50 mm	430 mm	2976 Kg
415 001 579	Kit with 2 air bags medium pressure, 1 bar Ø 760 mm	50 mm	590 mm	4650 Kg
415 001 580	Kit with 2 air bags medium pressure, 1 bar Ø 910 mm	50 mm	610 mm	6694 Kg
415 001 581	Kit with 2 air bags medium pressure, 1 bar Ø 1220 mm	100 mm	1000 mm	11902 Kg



CODE	DESCRIPTION
415 001 582	Carry bag for 2 air bags Ø 610 mm
415 001 583	Carry bag for 2 air bags Ø 760 mm
415 001 584	Carry bag for 2 air bags Ø 910 mm
415 001 585	Carry bag for 2 air bags Ø 1220 mm
415 001 586	Inflating hose, 5 m, YELLOW
415 001 587	Inflating hose, 5 m, RED
415 001 588	Dual controller, 1 bar
415 001 589	Deadman 1 Bar
415 001 590	Pressure reducer

# FLEXIBLE TANKS FOR DRINKING WATER



Flexible tanks for storing small or large quantities of drinking water. They are not subject to drying, evaporation or corrosion, and are extremely strong in mechanical terms. 4 steel rings in corners. The colour depends on availability. Resistance to temperatures from -10°C to +60°C

## FEATURES

- 2 complete PVC ball valves
- 1 overflow valve



CODE	DESCRIPTION	CAPACITY
415 001 475	Flexible tank for drinking water • 1480 x 2750 x h 400 mm	1 m <sup>3</sup>
415 001 477	Flexible tank for drinking water • 2300 x 2960 x h 450 mm	2 m <sup>3</sup>
415 001 479	Flexible tank for drinking water • 2850 x 2960 x h 600 mm	3 m <sup>3</sup>
415 001 481	Flexible tank for drinking water • 2960 x 3300 x h 650 mm	4 m <sup>3</sup>
415 001 483	Flexible tank for drinking water • 2960 x 3900 x h 700 mm	5 m <sup>3</sup>
415 001 485	Flexible tank for drinking water • 2960 x 6200 x h 900 mm	10 m <sup>3</sup>
415 001 487	Flexible tank for drinking water • 4400 x 5300 x h 1000 mm	15 m <sup>3</sup>
415 001 489	Flexible tank for drinking water • 4400 x 6500 x h 1100 mm	20 m <sup>3</sup>
415 001 491	Flexible tank for drinking water • 4400 x 7600 x h 1250 mm	25 m <sup>3</sup>
415 001 493	Flexible tank for drinking water • 5920 x 6700 x h 1250 mm	30 m <sup>3</sup>
415 001 495	Flexible tank for drinking water • 5920 x 7200 x h 1300 mm	35 m <sup>3</sup>
415 001 497	Flexible tank for drinking water • 5920 x 8600 x h 1400 mm	45 m <sup>3</sup>
415 001 499	Flexible tank for drinking water • 5920 x 9400 x h 1400 mm	50 m <sup>3</sup>
415 001 501	Flexible tank for drinking water • 5920 x 10500 x h 1500 mm	60 m <sup>3</sup>
415 001 503	Flexible tank for drinking water • 7400 x 9100 x h 1550 mm	70 m <sup>3</sup>
415 001 505	Flexible tank for drinking water • 7400 x 10300 x h 1550 mm	80 m <sup>3</sup>

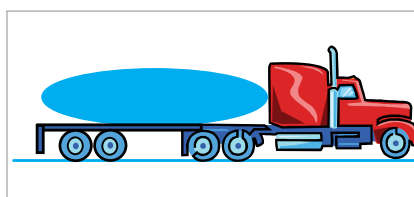

## LDPE WASHING BASINS

These washing basins allow removal of oily residue, encrustations and dirt from mechanical parts and components during ordinary and extraordinary maintenance of machine tools and mechanical equipment.

These operations allow an increase in the efficiency of such machinery and a related reduction in risk from their use, pursuant to Italian Legislative Decree 81/08.

The LDPE WASHING BASINS operate without solvents and help you meet the high requirements of current solvent regulations:

- Directive 1999/13/EC
- Directive 2004/2/EC
- Italian Ministerial Decree no.44 of 16 January 2004

Water-based degreasing uses natural micro-organisms, without the use of any solvent or cold degreaser, thus protecting the operative and the environment from hazardous volatile emissions. Oil biodegradation oils ensures a long life for the bath. Zero hazardous substances, zero hazardous goods, zero fire/flame risk. Equipped with a flexible system incorporating a rubber hose with brush and a flat tap.



416 002 495



416 002 496



CODE	DESCRIPTION	WORKING SURFACE H	CAPACITY	POWER SUPPLY
416 002 495	LDPE washing basin (W x D) 730 x 520 mm	910 - 980 mm	90 L	230V – 50 Hz
416 002 496	LDPE washing basin (W x D) 810 x 520 mm	860 - 1030 mm	100 L	230V – 50 Hz

## WASHING FLUID

Dermatologically tested washing fluid, dissolves and eliminates machining oil, cutting oil, corrosion protection products, light grease, dirt and dirt particles from parts.

Ready to use, it eliminates the risk of incorrect dilution and variations in quality, as well as the need to regularly analyse the bath. As it is a water-based liquid, it does not perforate surfaces, and can be used for cleaning any material, from plastic to steel.

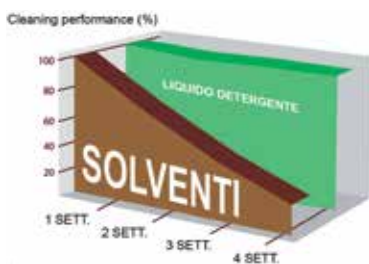

CODE	DESCRIPTION	PACK
416 002 505	Cleaning fluid for washing basins 416002495 and 416002496	20 L



## PAINTED STEEL SPRAYERS



416 001 600

416 001 601



416 001 602

Painted steel sprayer tanks for detergents, low density lubricants. Independent operation after addition of compressed air from 3-7 bar supply. Flow rate depending on nozzle installed. All models are equipped with a valve calibrated to max. 7 bar. Coupling: M 1/4" BSP.

CODE	DESCRIPTION	CAPACITY	MAXIMUM PRESSURE
416 001 600	Painted steel sprayer 400 x 310 x h 700 mm	16 L	7 bars
416 001 601	Painted steel sprayer 370 x 340 x h 820 mm	24 L	7 bars
416 001 602	Painted steel sprayer 400 x 430 x h 1020 mm	40 L	5 bars

## AISI 304 STAINLESS-STEEL SPRAYERS



416 001 603

416 001 604



416 001 605

Stainless-steel sprayer tank for detergents, low density lubricants. Independent operation after addition of compressed air from 3-7 bar supply. Flow rate depending on nozzle installed. All models are equipped with a valve calibrated to max. 7 bar. Coupling: M 1/4" BSP.

CODE	DESCRIPTION	CAPACITY	MAXIMUM PRESSURE
416 001 603	AISI 304 STAINLESS-STEEL sprayer Polyurethane hose • 400 x 310 x h 700 mm	24 L	7 bars
416 001 604	AISI 304 STAINLESS-STEEL sprayer Spiral hose • 370 x 340 x h 820 mm	24 L	7 bars
416 001 605	AISI 304 STAINLESS-STEEL sprayer Spiral hose • 400 x 430 x h 1020 mm	40 L	5 bars

## POLYETHYLENE (PE) SPRAYERS



416 002 526



416 002 527

Manual sprayers suitable for a wide range of industrial chemical products / degreasing agents and other liquids including oils, kerosene and solvents compatible with low density polyethylene (LDPE). All sprayers are equipped with pressure limiting valve, telescopic stainless-steel lance and adjustable nozzle.

CODE	DESCRIPTION	CAPACITY	PRESSURE
416 002 526	Polyethylene sprayer 220 x 220 x h 570 mm	9 L	0,4 MPa
416 002 527	Polyethylene backpack sprayer 410 x 170 x h 610 mm	16 L	0,3 MPa



416 003 951



416 003 952

CODE	DESCRIPTION	CAPACITY
416 003 951	Polyethylene (PE) sprayer • 100 x 100 x h 220 mm	0.5 L
416 003 952	Polyethylene (PE) sprayer • 115 x 115 x h 275 mm	1 L



Container equipped with rear wheels for easy movement. 12V diaphragm electric pump, flow rate 8.3 L/min, maximum pressure 4.8 bar. Continuous duty, Honeywell MICRO SWITCH™ pressure switch. Santoprene™ membrane and chemical-resistant Viton® valves. 4.5 m hose. Aluminium dispensing lance with gun. Flow rate 9m horizontally + 6m vertically. Power cable with pliers for connection to the power battery (e.g. vehicle battery), and switch.

CODE	DESCRIPTION	CAPACITY
416 004 501	Wheeled electric sprayer • 440 x 450 x h 1100 mm	110 L





# PRODUCTS FOR SAFETY AND MAINTENANCE

17	PROTECTIVE COATINGS FOR INDOOR/OUTDOOR SURFACES .....	page 292
	ANCHORING SYSTEMS .....	page 301
18	LABEL PRINTERS.....	page 303
	SAFETY SIGNAGE.....	page 305



# POTHOLESS



**The new cold-mix bituminous conglomerate, created with modified bitumen and structural fibres for urgent maintenance operations**

Different in its raw materials, POTHOLESS is the first cold-mix bituminous conglomerate created with bitumen modified with plastomers/polymers and structural fibres suitably mixed with a mostly basaltic grit (size 0-8 mm) in a unique production process. All this, besides giving the product excellent performance alongside ease of use, bestows an unusual but refined opacity to this conglomerate. This opacity provides superior performance compared to competitor products: it means POTHOLESS does not stick to car tyres when traffic is reopened, avoiding the usual unwanted results of grit crumbling and scattering on the road surface; at the same time, it is this same feature which creates a strong link between the conglomerate particles.

## STRONG POINTS

- Ecologically friendly asphalt, as it is produced using a cold process, without atmospheric CO<sub>2</sub> emissions
- Immediate adherence to existing asphalt
- Easy to lay, does not require specific equipment
- Does not stick to vehicle tyres

## APPLICATIONS

- Roads
- Motorways
- Pavements
- Courtyards
- Ramps
- Car parks

## FEATURES

- Easy to use (when cold, simply levelling with a shovel or spade)
- Integrates with existing asphalt without crumbling and scattering
- Can also be used at low temperatures
- Resistant to extreme weather (snow, ice and heavy rain)
- Can be stored for up to 6-8 months

CODE	DESCRIPTION	PACKAGING
417 001 569	POTHOLESS cold-use eco asphalt	25 kg bag
417 001 570		60 bags x 25 kg



WATCH THE VIDEO



Pictures indicated in this catalogue are representative and not binding for the supplier in terms of layout and colours. They may be subject to changes by the supplier without prior notice.

# ICELESS

 AIRBANK PRODUCT



## Ice and snow melter which respects the roads, cars and the environment: the convenience of salt, without its disadvantages

Salt has always been the solution adopted to deal with the problem of icy roads. But what consequences can salt cause over the winter period? Salt is a corrosive substance, so the use of large quantities can damage road surfaces, in particular asphalt. This leads every year to the formation of holes in the road and the consequent use of costly additions to maintain and restore the road surface. Salt corrodes metal and so precipitates the formation of rust on car underbodies, alloy wheels and body shells, even damaging the reinforcing bar used in reinforced concrete. Each trolley will be provided with gasket and lock.



Polyethylene (PE) trunk  
code 413 001 357 page 250

### STRONG POINTS

- ICELESS guarantees optimal performance down to  $-28^{\circ}\text{C}$  (SALT, on the other hand, acts down to a temperature of  $-1^{\circ}\text{C}$ )
- ICELESS does not damage the asphalt, eliminating repair and maintenance costs (SALT, on the other hand, is a corrosive substance and damages the road surface)
- ICELESS, compared to salt, acts three times faster (SALT, on the other hand, has a herbicidal effect)

### APPLICATIONS

- Roads
- Motorways
- Pavements
- Courtyards
- Ramps
- Car parks
- Walkways

### FEATURES

- Environmentally friendly
- Does not damage cars or the road surface
- Acts down to  $-28^{\circ}\text{C}$
- Does not pollute the water table
- Easy to use
- Acts three times faster than salt



Trolley  
413 004 324 page 246

CODE	DESCRIPTION	PACKAGING
417 002 602	ICELESS ecological snow and ice melter	25 kg bag
417 002 603		40 bags x 25 kg



Pictures indicated in this catalogue are representative and not binding for the supplier in terms of layout and colours. They may be subject to changes by the supplier without prior notice.

# LIQUID ICELESS



## Snow and ice barrier

ICELESS LIQUID is a liquid calcium chloride-based agent, designed to be used both for ice prevention and de-icing. It is ideal for all sectors where ice and snow can cause problems for persons and machinery. Its most common uses are for pavements, roads, bridges, footbridges, slipways, parking bays, boulevards, squares and all areas for road traffic or pedestrian access. It must be sprayed on the external surface before precipitation to prevent any ice forming, also forming a barrier between the treated surface and snow, and preventing ice build-up. This allows any snow to be removed more easily, as it does not take hold on the surface.

### STRONG POINTS

- LIQUID ICELESS is ready to use
- LIQUID ICELESS does not damage asphalt, eliminating repair and maintenance costs (SALT, on the other hand, is a corrosive substance and damages the road surface)
- LIQUID ICELESS works down to -20°

### APPLICATIONS

- Roads
- Motorways
- Pavements
- Courtyards
- Ramps
- Car parks
- Walkways

### FEATURES

- Appearance: slightly milky liquid
- Colour: none
- Content: CaCl<sub>2</sub> 35%
- pH: 8

CODE	DESCRIPTION	PACKAGING
417 003 082	ICELESS snow and ice barrier	25 Kg jerrycan
417 003 081		250 Kg drum



Pictures indicated in this catalogue are representative and not binding for the supplier in terms of layout and colours. They may be subject to changes by the supplier without prior notice.

# MATS

## “LIGHT DUTY” SERIES MAT RUNNER

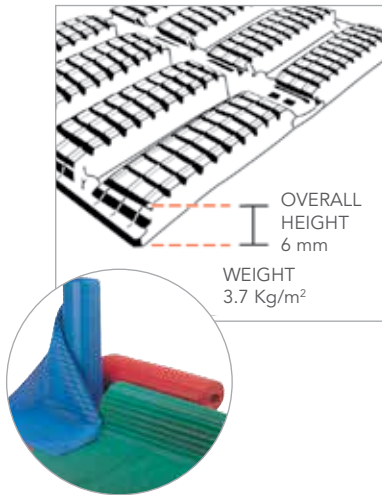

Light-weight, low-cost and comfortable, soft underfoot and decorative. Easy to roll up when cleaning, making it ideal for bars and catering facilities where occasional spills can occur. High performance thanks to its non-slip surface and open-grid design for fast draining.

CODE	DESCRIPTION	THICKNESS	COLOUR
417 001 662	Light-weight series mat runner • 600 mm x 10 m	6 mm	Green
417 001 663	Light-weight series mat runner • 910 mm x 10 m	6 mm	
417 001 665	Light-weight series mat runner • 600 mm x 10 m	6 mm	Blue
417 001 666	Light-weight series mat runner • 910 mm x 10 m	6 mm	
417 001 668	Light-weight series mat runner • 600 mm x 10 m	6 mm	Red
417 001 669	Light-weight series mat runner • 910 mm x 10 m	6 mm	

## “MEDIUM DUTY” SERIES MAT RUNNER

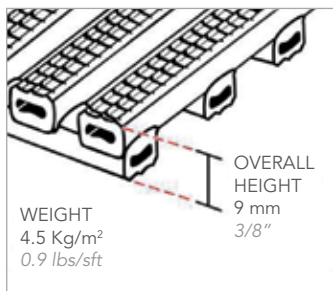

The open-grid design and 9 mm height deal effectively with water dispersion and spills. Its dual-layer tubular structure also provides excellent comfort and insulation where cold, hard floors are otherwise an issue, especially where workers must remain standing for lengthy periods.

CODE	DESCRIPTION	THICKNESS	COLOUR
417 001 671	Medium-weight series mat runner • 500 mm x 10 m	9 mm	Black
417 001 672	Medium-weight series mat runner • 750 mm x 10 m	9 mm	
417 001 673	Medium-weight series mat runner • 1000 mm x 10 m	9 mm	

## “HEAVY DUTY” SERIES MAT RUNNER

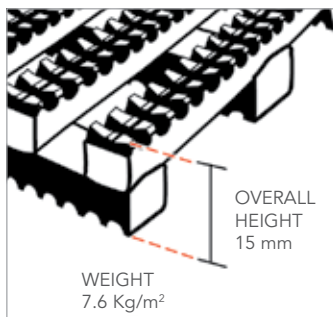

This mat runner carries the UK's highest slip resistance rating (DIN 51130) as a result of its tread pattern. Excellent slip resistance is coupled with a top liquid drainage rating (meeting the UK's highest DIN standards). Open grid design to effectively remove liquid and debris. It is hygienic, easy to clean and provides excellent cushioning, thermal and sound damping properties. It is made from two layers of non-porous, flexible PVC which are welded together to create extra strong joints.

CODE	DESCRIPTION	THICKNESS	COLOUR
417 001 674	Heavy-weight series mat runner • 600 mm x 10 m	15 mm	Black
417 001 675	Heavy-weight series mat runner • 910 mm x 10 m	15 mm	
417 001 676	Heavy-weight series mat runner • 1220 mm x 10 m	15 mm	
417 001 677	Heavy-weight series mat runner • 600 mm x 10 m	15 mm	Blue
417 001 678	Heavy-weight series mat runner • 910 mm x 10 m	15 mm	
417 001 679	Heavy-weight series mat runner • 1220 mm x 10 m	15 mm	
417 001 680	Heavy-weight series mat runner • 600 mm x 10 m	15 mm	Red
417 001 681	Heavy-weight series mat runner • 910 mm x 10 m	15 mm	
417 001 682	Heavy-weight series mat runner • 1220 mm x 10 m	15 mm	
417 001 682	Heavy-weight series mat runner • 1220 mm x 10 m	15 mm	

Pictures indicated in this catalogue are representative and not binding for the supplier in terms of layout and colours. They may be subject to changes by the supplier without prior notice.



# RUNNER FOR THE FOOD INDUSTRY

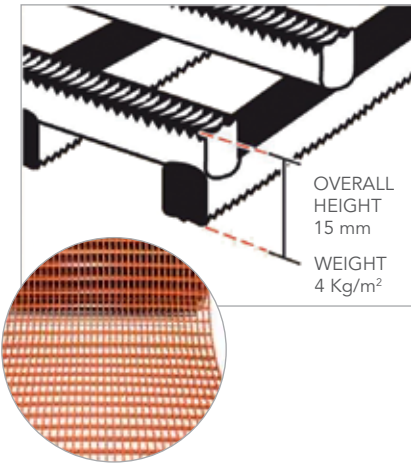

Made from top-quality materials. Excellent anti-slip qualities. The material is treated with anti-bacterial and anti-fungal products, and is therefore suitable for use in the food industry. Featuring a coarse weave for better fluid drainage, it is also resistant to corrosion from animal fats.

CODE	DESCRIPTION	THICKNESS	COLOUR
417 003 795	Runner for the food sector - 600 mm x 5 m	15 mm	Terracotta

## FLOOR MATS

### “LIGHT-WEIGHT” SERIES ANTI-FATIGUE FLOOR MAT AND RUNNER

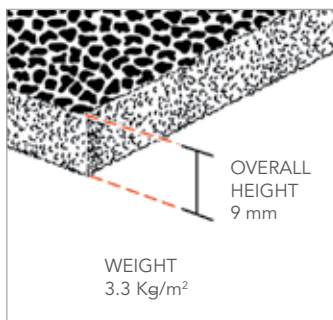

Anti-static.  
Composed of high molecular density foam with bounce properties up to 4 times as effective as standard foam matting.  
Improves working conditions for employees who must spend long periods standing up.  
Also provides protection from accidental damage to dropped items.

CODE	DESCRIPTION	THICKNESS	COLOUR
417 001 685	Light-weight series anti-fatigue floor mat • 600 mm x 910 mm	9 mm	Grey
417 001 686	Light-weight series anti-fatigue floor mat • 910 mm x 1500 mm	9 mm	
417 001 687	Light-weight series anti-fatigue floor mat • 910 mm x 3000 mm	9 mm	
417 001 688	Light-weight series anti-fatigue floor mat • 600 mm x 910 mm	9 mm	Blue
417 001 689	Light-weight series anti-fatigue floor mat • 910 mm x 1500 mm	9 mm	
417 001 690	Light-weight series anti-fatigue floor mat • 910 mm x 3000 mm	9 mm	

CODE	DESCRIPTION	THICKNESS	COLOUR
417 001 683	Light-weight series anti-fatigue runner • 910 mm x 18 m	9 mm	Grey
417 001 684	Light-weight series anti-fatigue runner • 910 mm x 18 m	9 mm	Blue

### “ECO” SERIES ANTI-FATIGUE FLOOR MAT AND RUNNER

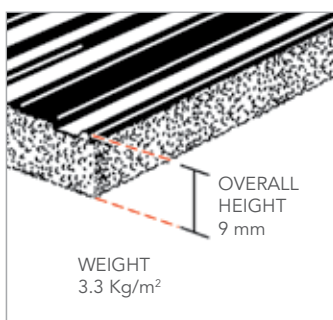

Good value, hard-wearing, anti-fatigue matting of closed-cell PVC foam composition with a ribbed anti-slip surface for light duty use. It also reduces impact noise and protects accidentally dropped items.

CODE	DESCRIPTION	THICKNESS	COLOUR
417 001 697	ECO series anti-fatigue floor mat • 600 mm x 910 mm	9 mm	Grey
417 001 698	ECO series anti-fatigue floor mat • 910 mm x 1500 mm	9 mm	
417 001 699	ECO series anti-fatigue floor mat • 910 mm x 3000 mm	9 mm	

CODE	DESCRIPTION	THICKNESS	COLOUR
417 001 700	ECO series anti-fatigue runner • 910 mm x 18 m	9 mm	Grey

Pictures indicated in this catalogue are representative and not binding for the supplier in terms of layout and colours. They may be subject to changes by the supplier without prior notice.

### “MEDIUM-WEIGHT” SERIES ANTI-FATIGUE FLOOR MAT

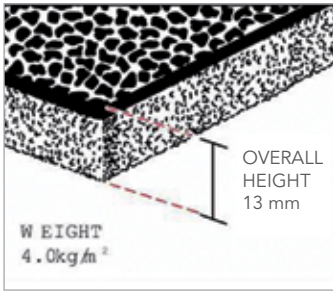

A convenient, robust closed-cell anti-fatigue floor mat with a grained anti-slip layer and good wear resistance.

Thicker PVC foam for greater comfort and lifespan.

It also reduces impact noise and protects accidentally dropped items.

CODE	DESCRIPTION	THICKNESS	COLOUR
417 003 319	“Medium-weight” series anti-fatigue floor mat 600 mm x 910 mm	13 mm	Grey
417 003 320	“Medium-weight” series anti-fatigue floor mat 910 mm x 1500 mm	13 mm	
417 003 321	“Medium-weight” series anti-fatigue floor mat 910 mm x 3000 mm	13 mm	

### “HEAVY-WEIGHT” SERIES ANTI-FATIGUE FLOOR MAT AND RUNNER

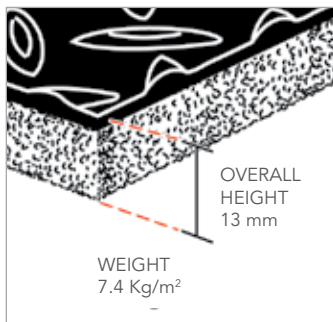

Multi-function anti-fatigue matting composed of a foam which is thermally fused with a robust anti-slip covering with a checkerboard design. Chemical, oil and acid resistant.

CODE	DESCRIPTION	THICKNESS	COLOUR
417 001 691	Heavy-weight series anti-fatigue floor mat • 600 mm x 910 mm	13 mm	Black
417 001 692	Heavy-weight series anti-fatigue floor mat • 910 mm x 1500 mm	13 mm	
417 001 693	Heavy-weight series anti-fatigue floor mat • 910 mm x 3000 mm	13 mm	

CODE	DESCRIPTION	THICKNESS	COLOUR
417 001 694	Heavy-weight series anti-fatigue runner • 910 mm x 18 m	13 mm	Black
417 001 696	Heavy-weight series anti-fatigue runner • 910 mm x 18 m	13 mm	Black with yellow edging

### ANTI-FATIGUE AND ANTI-SPARK FLOOR MAT

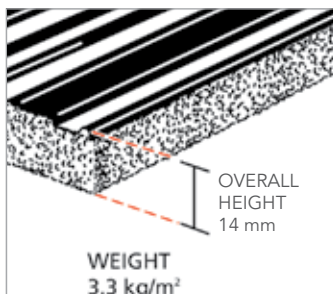

Anti-static and anti-slip mat composed of two layers of rubber.

Heat resistant and suitable for use in the presence of sparks and fragments of hot metal.

CODE	DESCRIPTION	THICKNESS	COLOUR
417 003 322	Anti-fatigue and anti-spark floor mat • 600 mm x 910 mm	14 mm	Black
417 003 323	Anti-fatigue and anti-spark floor mat • 910 mm x 1500 mm	14 mm	

Pictures indicated in this catalogue are representative and not binding for the supplier in terms of layout and colours. They may be subject to changes by the supplier without prior notice.

## DECONTAMINATING MAT

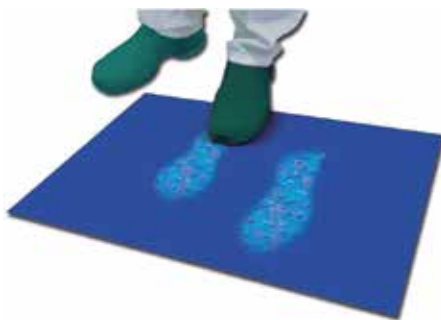

Decontaminating mat with numerical indicator to be applied on floors for removing dirt from shoes and trolley wheels.

### FEATURES

- Material: LDPE
- Colour: blue
- Packaging: Cardboard boxes with 8 pieces with 30 layers per mat.
- Characteristics: Thickness 50 micron  $\pm$  10%
- Sticker: 6 g/sqm  $\pm$  1 g/sqm
- Indicator: from 30 to 1
- Bacteriostatic agent: Ethyl acetate
- Bactericide: Isothiazoline

**Storage:** Decontaminating mats must be stored strictly in a horizontal position and possibly sealed and protected against contact with air and dust, in a clean dry place and away from direct heat sources. Be careful to prevent the alteration of the adhesive power that would occur if the package were left open and in contact with moisture or excessive heat.

**Notes:** Latex free – The material does not produce dioxins in case of incineration

CODE	DESCRIPTION	PACKAGING
417 004 474	Decontaminating mat with numerical indicator 90 x 115 cm	8 mats of 30 sheets each

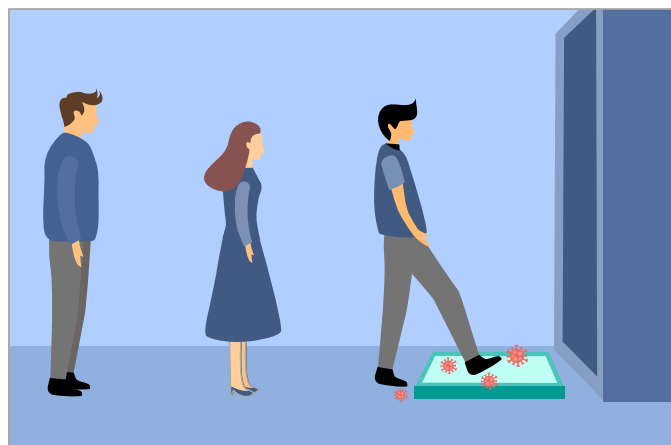

Pictures indicated in this catalogue are representative and not binding for the supplier in terms of layout and colours. They may be subject to changes by the supplier without prior notice.

# CABLE PROTECTOR RAMP

Rubber cable protection ramp with folding high-visibility yellow anti-slip cover.  
 Two-channel cable protector ramp: capacity 3000 Kg.  
 Three-channel cable protector ramp: capacity 5000 Kg.



CODE	DESCRIPTION	CONDUIT DIMENSIONS
417 003 062	2-channel cable protector ramp • 1000 x 250 x h 35 mm	20 x 30 mm
417 003 063	Corner for 2-channel cable protector ramp • 30° angle section	20 x 30 mm
417 002 946	3-channel cable protector ramp • 960 x 600 x h 75 mm	55 x 50 mm 68 x 50 mm 68 x 50 mm
417 003 061	Corner for 3-channel cable protector ramp • 45° angle section (Pack of 2 pcs)	55 x 50 mm 68 x 50 mm 68 x 50 mm



Pictures indicated in this catalogue are representative and not binding for the supplier in terms of layout and colours. They may be subject to changes by the supplier without prior notice.



# DROPLESS



## Liquid to make surfaces oil- and water-repellent

DROPLESS is a next-generation nanotechnology product for long-lasting water- and oil-proofing protection of any type of porous surface. After applying the product, the treated surfaces and equipment will be easier to handle as they are cleaner and safer. The product is ready to use and can be applied by brush, roller or airless spray; the surface to be treated must be clean, dry and free of grease before application. The quantity required will depend on the surface porosity and roughness, but as an approximate guide allow for 30 to 80 ml/m<sup>2</sup>; drying time is approximately 24 hours at ambient temperature, although higher temperatures may accelerate hardening.



### STRONG POINTS

- Makes surfaces water- and oil-repellent
- Repels dirt
- Resistant to bad weather
- Easy to apply
- Biocompatible
- UV-resistant
- Permanent
- Breathable

### APPLICATIONS

- All kinds of natural stone
- Bricks
- Concrete
- Concrete blocks
- Tools
- Fabrics
- Untreated wood
- Porous flooring
- Exterior building cladding

### FEATURES

- Consistency: liquid
- Colour: transparent
- Working temperature: +5° to +35°C
- Solubility: forms emulsion in water

CODE	DESCRIPTION	PACKAGING
408 002 808	DROPLESS liquid to make surfaces oil- and water-repellent	5 L jerrycan
408 002 809		25 L jerrycan
417 002 989	DROPLESS display kit	9 x 500 ml spray bottles



417 002 989



WATCH THE VIDEO



Pictures indicated in this catalogue are representative and not binding for the supplier in terms of layout and colours. They may be subject to changes by the supplier without prior notice.

# VALVE LOCKOUTS

## LOCKOUTS FOR BALL VALVES IN CLOSED POSITION



Locks quarter-turn ball valves in OFF position. To be used together with a padlock.

CODE	DESCRIPTION	MIN. SHACKLE CLEARANCE	Ø MAX LOCK HOLE
800 065 666	Lockouts for ball valves, nylon • valve lever width 6-25 mm	25 mm	7.5 mm
800 065 692	Lockouts for ball valves, steel • valve lever width 6-25 mm	19 mm	10 mm
800 065 669	Lockouts for ball valves, steel • valve lever width 36-76 mm	19 mm	7.5 mm
800 065 693	Lockouts for ball valves, steel • valve lever width 36-76 mm	19 mm	10 mm

## HANDWHEEL VALVE LOCKOUT



Safe and simple locking system for gate valves. Made of durable polypropylene (PP), resistant to chemicals, high and low temperatures.

CODE	DESCRIPTION	COLOUR
800 065 560	Handwheel valve lockout • handwheel Ø: 25-64 mm	RED
800 065 590	Handwheel valve lockout • handwheel Ø: 25-64 mm	YELLOW
800 065 595	Handwheel valve lockout • handwheel Ø: 25-64 mm	GREEN
800 065 585	Handwheel valve lockout • handwheel Ø: 25-64 mm	BLUE
800 065 561	Handwheel valve lockout • handwheel Ø: 64-127 mm	RED
800 065 591	Handwheel valve lockout • handwheel Ø: 64-127 mm	YELLOW
800 065 596	Handwheel valve lockout • handwheel Ø: 64-127 mm	GREEN
800 065 586	Handwheel valve lockout • handwheel Ø: 64-127 mm	BLUE
800 065 562	Handwheel valve lockout • handwheel Ø: 127-165 mm	RED
800 065 592	Handwheel valve lockout • handwheel Ø: 127-165 mm	YELLOW
800 065 597	Handwheel valve lockout • handwheel Ø: 127-165 mm	GREEN
800 065 587	Handwheel valve lockout • handwheel Ø: 127-165 mm	BLUE
800 065 563	Handwheel valve lockout • handwheel Ø: 165-254 mm	RED
800 065 593	Handwheel valve lockout • handwheel Ø: 165-254 mm	YELLOW
800 065 598	Handwheel valve lockout • handwheel Ø: 165-254 mm	GREEN
800 065 588	Handwheel valve lockout • handwheel Ø: 165-254 mm	BLUE
800 065 564	Handwheel valve lockout • handwheel Ø: 254-320 mm	RED
800 065 594	Handwheel valve lockout • handwheel Ø: 254-320 mm	YELLOW
800 065 599	Handwheel valve lockout • handwheel Ø: 254-320 mm	GREEN
800 065 589	Handwheel valve lockout • handwheel Ø: 254-320 mm	BLUE

## SAFETY LOCKOUT



Allow 6 workers to lock out a single energy source, in vinyl covered stainless steel, rust-proof.

Max shackle diameter: 9.5 mm.

CODE	DESCRIPTION	PACKAGING
800 805 840	Multiple safety lockout • ring Ø: 25 mm • RED	12 pieces
800 805 841	Multiple safety lockout • ring Ø: 38 mm • RED	12 pieces
800 805 842	Multiple safety lockout • ring Ø: 25 mm • YELLOW	12 pieces
800 805 843	Multiple safety lockout • ring Ø: 38 mm • YELLOW	12 pieces

Pictures indicated in this catalogue are representative and not binding for the supplier in terms of layout and colours. They may be subject to changes by the supplier without prior notice.

## LOCKOUTS FOR EUROPEAN CIRCUIT BREAKERS



Effective method for locking out European Circuit Breakers.  
Easily installs with the aid of a push button.  
The TBLO (Tie Bar LOCKout) model has a thumb wheel for quick application.  
Robust, glass-filled nylon.  
To be used with a padlock with shackle diameter up to 6 mm.

CODE	DESCRIPTION	PACKAGING
800 090 844	Lockout for European circuit breakers • POS system	1 piece
800 090 845	Lockout for European circuit breakers • POS system	6 pieces
800 090 847	Lockout for European circuit breakers • PIS system	1 piece
800 090 848	Lockout for European circuit breakers • PIS system	6 pieces
800 090 850	Lockout for European circuit breakers • POW system	1 piece
800 090 851	Lockout for European circuit breakers • POW system	6 pieces
800 090 853	Lockout for European circuit breakers • TBLO system	1 piece
800 090 854	Lockout for European circuit breakers • TBLO system	6 pieces

POS = Pin Out Standard  
PIS = Pin In Standard  
POW = Pin Out Wide  
TBLO = Tie Bar Lock Out

## OSHA SAFETY PADLOCKS

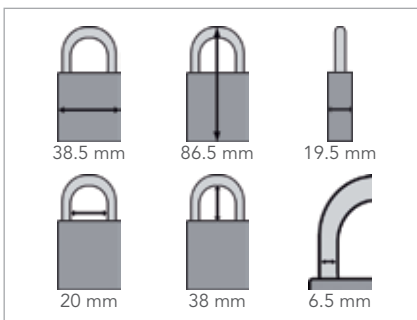

Unique padlock design to be used for safety lockout applications.  
Durable, corrosion- and chemical-resistant construction.  
Each padlock is supplied with one key and two labels; the pack contains 6 padlocks.

CODE	DESCRIPTION	PACKAGING
800 051 344	OSHA safety padlocks • BLUE	6 pieces
800 051 339	OSHA safety padlocks • RED	6 pieces
800 051 353	OSHA safety padlocks • BLACK	6 pieces
800 051 346	OSHA safety padlocks • YELLOW	6 pieces
800 051 345	OSHA safety padlocks • GREEN	6 pieces
800 051 347	OSHA safety padlocks • ORANGE	6 pieces

Pictures indicated in this catalogue are representative and not binding for the supplier in terms of layout and colours. They may be subject to changes by the supplier without prior notice.



## i3300

### Safety signs and label printer

New printer ideal for industrial signs and labels. Easy to use, it features a large LCD touchscreen display, an intuitive home screen and a full QWERTY keyboard for easy and quick label creation using text, symbols and bar codes. Use as a stand-alone printer or connected to a PC by USB cable. Fast 3 IPS printing. 300 dpi print resolution. Large colour touchscreen display. Prints on labels 13 to 100 mm wide. 8 print ribbon colours. 13 different materials in 16 different colours.

### PACKAGE INCLUDES

- USB cable
- Cleaning kit
- Cutter cleaning tool
- Quick Start Guide
- Case for printer documentation
- CD drivers
- Drivers
- User manuals in 11 languages
- Mouse

### SOME FUNCTIONS

- Multiple language and character sets for use in different areas
- Supplies are easy to load
- Automatic label formatting thanks to the "Smart chip" material which communicates the label type, size and colour to the printer.
- Automatic character size
- Printing mouth width 46 mm
- Length up to 101.60 mm

## OUTDOOR ADHESIVE TAPES WITH 2-YEAR WARRANTY

CODE	DESCRIPTION
800 149 553	i3300 WIFI PRINTER - Stand alone
800 241 118	i3300 WIFI PRINTER + Workstation Software
800 142 117	Dust cover for printer
800 142 116	Cutter tool

### Colored tape

CODE	DESCRIPTION
800 118 084	BLACK print ribbon • (Width 110 mm - Length 61 m)
800 118 088	ORANGE print ribbon • (Width 110 mm - Length 61 m)
800 118 091	YELLOW print ribbon • (Width 110 mm - Length 61 m)
800 118 086	GREEN print ribbon • (Width 110 mm - Length 61 m)
800 118 089	RED print ribbon • (Width 110 mm - Length 61 m)
800 118 085	BLUE print ribbon • (Width 110 mm - Length 61 m)
800 118 090	WHITE print ribbon • (Width 110 mm - Length 61 m)

Pictures indicated in this catalogue are representative and not binding for the supplier in terms of layout and colours. They may be subject to changes by the supplier without prior notice.



#### Vinyl tape

CODE	DESCRIPTION	CODE	DESCRIPTION
<b>Height 13 mm - Length 30 m</b>		<b>Height 57 mm - Length 30 m</b>	
800 141 990	Vinyl adhesive tape BLACK • 30 m x h 13 mm	800 141 988	Vinyl adhesive tape BLACK • 30 m x h 57 mm
800 141 994	Vinyl adhesive tape BLUE • 30 m x h 13 mm	800 141 992	Vinyl adhesive tape BLUE • 30 m x h 57 mm
800 141 998	Vinyl adhesive tape BROWN • 30 m x h 13 mm	800 141 996	Vinyl adhesive tape BROWN • 30 m x h 57 mm
800 142 002	Vinyl adhesive tape TRANSPARENT • 30 m x h 13 mm	800 142 000	Vinyl adhesive tape TRANSPARENT • 30 m x h 57 mm
800 142 006	Vinyl adhesive tape GOLD • 30 m x h 13 mm	800 142 004	Vinyl adhesive tape GOLD • 30 m x h 57 mm
800 142 010	Vinyl adhesive tape GREEN • 30 m x h 13 mm	800 142 008	Vinyl adhesive tape GREEN • 30 m x h 57 mm
800 142 014	Vinyl adhesive tape GREY • 30 m x h 13 mm	800 142 012	Vinyl adhesive tape GREY • 30 m x h 57 mm
800 142 018	Vinyl adhesive tape ORANGE • 30 m x h 13 mm	800 142 016	Vinyl adhesive tape ORANGE • 30 m x h 57 mm
800 142 022	Vinyl adhesive tape PURPLE • 30 m x h 13 mm	800 142 020	Vinyl adhesive tape PURPLE • 30 m x h 57 mm
800 142 026	Vinyl adhesive tape RED • 30 m x h 13 mm	800 142 024	Vinyl adhesive tape RED • 30 m x h 57 mm
800 142 031	Vinyl adhesive tape WHITE • 30 m x h 13 mm	800 142 029	Vinyl adhesive tape WHITE • 30 m x h 57 mm
800 142 036	Vinyl adhesive tape YELLOW • 30 m x h 13 mm	800 142 034	Vinyl adhesive tape YELLOW • 30 m x h 57 mm
<b>Height 29 mm - Length 30 m</b>		<b>Height 76 mm - Length 30 m</b>	
800 141 989	Vinyl adhesive tape BLACK • 30 m x h 29 mm	800 142 028	Vinyl adhesive tape WHITE • 30 m x h 76 mm
800 141 997	Vinyl adhesive tape BROWN • 30 m x h 29 mm	800 142 033	Vinyl adhesive tape YELLOW • 30 m x h 76 mm
800 142 001	Vinyl adhesive tape TRANSPARENT • 30 m x h 29 mm	<b>Height 100 mm - Length 30 m</b>	
800 142 005	Vinyl adhesive tape GOLD • 30 m x h 29 mm	800 141 991	Vinyl adhesive tape BLUE • 30 m x h 100 mm
800 142 009	Vinyl adhesive tape GREEN • 30 m x h 29 mm	800 141 995	Vinyl adhesive tape BROWN • 30 m x h 100 mm
800 142 013	Vinyl adhesive tape GREY • 30 m x h 29 mm	800 141 999	Vinyl adhesive tape TRANSPARENT • 30 m x h 100 mm
800 142 017	Vinyl adhesive tape ORANGE • 30 m x h 29 mm	800 142 003	Vinyl adhesive tape GOLD • 30 m x h 100 mm
800 142 021	Vinyl adhesive tape PURPLE • 30 m x h 29 mm	800 142 007	Vinyl adhesive tape GREEN • 30 m x h 100 mm
800 142 025	Vinyl adhesive tape RED • 30 m x h 29 mm	800 142 011	Vinyl adhesive tape GREY • 30 m x h 100 mm
800 142 030	Vinyl adhesive tape WHITE • 30 m x h 29 mm	800 142 015	Vinyl adhesive tape ORANGE • 30 m x h 100 mm
800 142 035	Vinyl adhesive tape YELLOW • 30 m x h 29 mm	800 142 019	Vinyl adhesive tape PURPLE • 30 m x h 100 mm
800 146 042	Vinyl adhesive tape OCHRE • 30 m x h 29 mm	800 142 023	Vinyl adhesive tape RED • 30 m x h 100 mm
		800 142 027	Vinyl adhesive tape WHITE • 30 m x h 100 mm
		800 142 032	Vinyl adhesive tape YELLOW • 30 m x h 100 mm
		800 146 044	Vinyl adhesive tape OCHRE • 30 m x h 100 mm



Pictures indicated in this catalogue are representative and not binding for the supplier in terms of layout and colours. They may be subject to changes by the supplier without prior notice.

## ADHESIVE TAPE FOR FLOOR MARKING/SIGNAGE

ON REQUEST

These adhesive tapes for floor marking/signage are made of a new polyester, ideal for marking out corridors, aisles, wards, storage areas, safety equipment and exit routes.

### FEATURES

- Longer lasting
- Easy to apply
- High visibility (glossy surface)
- Punched shapes with different colours, pre-spaced for dashed lines, dots and arrows
- Resistant to corrosive chemicals



## INSPECTION STICKERS AND TAGS

ON REQUEST

Establishing the maintenance and repair status of machinery is key for the safety of the work environment. Stickers with the inspection date can be used whenever a machine requires frequent or regular inspections. Simply punch the sticker and apply it where it is required. Inspection stickers are suitable for machinery and equipment with a flat surface on which to apply them.

Unitag, Microtag and Nanotag are all designed to clearly indicate, at the point of use, the date of the next inspection/test, or the safe working load (SWL) of a machine. The inspection tags are suitable for equipment for which fastening with an openable ring or strap is preferable. The most common applications are, for example, safety wiring and lifting equipment.

All tags are based on an exclusive system composed of an insert and an insert holder, which guarantee immediate visibility of the current state of the equipment at the point of use. If the equipment passes the inspection, the insert is fitted into the insert holder so as to show up-to-date information on the equipment to any user. If the equipment does not pass any point of the inspection, just remove the insert from the insert holder to display the message "DO NOT USE".

The range of colours available for the inserts makes the information conveyed more visually immediate.



Pictures indicated in this catalogue are representative and not binding for the supplier in terms of layout and colours. They may be subject to changes by the supplier without prior notice.







# PRODUCTS FOR STORAGE AND TRANSPORT OF LITHIUM BATTERIES

19 PRODUCTS FOR STORAGE AND TRANSPORT OF LITHIUM BATTERIES .....page 308



# LITHIUM BATTERIES

In conditions of unusual operation of the lithium battery, the cells can undergo an uncontrolled process called "thermal runaway". Thermal runaway implies a rapid rise in the battery cells' temperature, accompanied by the release of flammable gases, which could easily be triggered by the high temperature reached by the battery, causing a fire. Thermal runaway can also be responsible for mechanical effects, such as the projection of fragments and the release of toxic gases and vapours. Among the various products, emissions of fluorine compounds are the most worrying. Hydrofluoric acid (HF) is one of these, but there are also others, such as phosphorus oxyfluoride (POF3). These compounds are formed by the fluorine contained within the components of the lithium ion cell, such as the binder (PVDF) or lithium salt, most commonly used in the electrolyte (LiPF6). Hydrofluoric acid is extremely toxic both by inhalation of its gaseous form and by contact with the aqueous solution.

The total amount of HF varies considerably based on the cell types.

Transport of lithium batteries and equipment containing them is configured as transport of dangerous goods, therefore UN approved containers will be required for this scope.

Typically, lithium batteries are transported in Class 9 and assigned to the following headings:

CODE	DESCRIPTION
3090	LITHIUM METAL BATTERIES (including lithium alloy batteries)
3091	LITHIUM METAL BATTERIES CONTAINED IN EQUIPMENT (including lithium alloy batteries)
3091	LITHIUM METAL BATTERIES PACKED WITH EQUIPMENT (including lithium alloy batteries)
3480	LITHIUM ION BATTERIES (including lithium ion polymer batteries)
3481	LITHIUM ION BATTERIES CONTAINED IN EQUIPMENT (including lithium ion polymer batteries)
3481	LITHIUM ION BATTERIES PACKED WITH EQUIPMENT (including lithium ion polymer batteries)
3536	LITHIUM BATTERIES INSTALLED IN FREIGHT UNITS lithium ion batteries or lithium metal batteries

Elements and batteries must be protected so as to prevent short circuits. This includes protection against contact with conductive materials within the same packaging that could cause a short circuit.

Even when these batteries and the equipment containing them reach the end of their life and become waste, they must be transported in suitable ADR approved containers for road transport.

Source: "Risks associated with the storage of lithium-ion batteries, ENEA"



Pictures indicated in this catalogue are representative and not binding for the supplier in terms of layout and colours. They may be subject to changes by the supplier without prior notice.

# FLEXIBLE, PORTABLE TANKS FOR ELECTRIC AND HYBRID VEHICLE MAINTENANCE

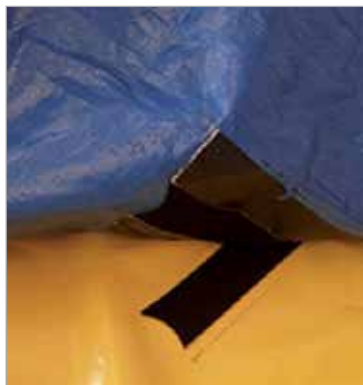

Detail of the fixing between the tank and the liner.



Flexible and portable PVC tanks, with polyethylene liner. These devices allow you to work safely in spillage situations related to electric and hybrid car battery failures during maintenance.

CODE	DESCRIPTION	DIMENSIONS	CAPACITY
419 004 627	Flexible PVC tank + PE liner	5 x 3 x h 0.10 m	1,500 L
419 004 628	Flexible PVC tank + PE liner	5 x 3 x h 0.15 m	2,250 L
419 004 629	PE liner for tank 410 004 627	5 x 3 x h 0.10 m	1,500 L
419 004 630	PE liner for tank 410 004 628	5 x 3 x h 0.15 m	2,250 L



Pictures indicated in this catalogue are representative and not binding for the supplier in terms of layout and colours. They may be subject to changes by the supplier without prior notice.

# SAFETY CABINETS FOR LITHIUM BATTERY STORAGE



## MANUFACTURED IN COMPLIANCE WITH STANDARD DIN EN 14470-1

Fire resistant safety cabinets, suitable for storing lithium batteries. Fire resistance 90 minutes according to DIN EN 14470-1 for internal and external fire.

### FEATURES

- Shelf load capacity: 60 kg
- Total weight: approx. 235 kg
- Lower collecting tank capacity: 49 L
- GS and CE certified
- Made of non-flammable material (class A2), with external coating
- Cabinet body external finish: light grey, similar to RAL 7035
- With cable passage preset
- Ventilation openings on the back, with automatic closure in case of fire
- Drawer with automatic stop, with automatic closure in case of fire
- Closable with cylinder lock, including closing indicator
- Wheels for floor handling

CODE	DESCRIPTION	DIMENSIONS
419 004 594	Lithium battery safety cabinet w/drawer	External 110 x 57 x h 63 cm • Internal 87 x 43 x h 46.6 cm



### FEATURES

- Shelf load capacity: 75 kg
- Total weight: approx. 600 kg
- Lower collecting tank capacity: 44 L
- GS and CE certified
- Made of non-flammable material (class A2), with external coating
- Cabinet body external finish: light grey, similar to RAL 7035
- Dual-leaf door with lock;
- Automatic closing of the doors in case of fire (via integrated release unit)
- Stainless steel hinges, metal handle
- Easily removable bottom baseboard for forklift movement
- Adjustable feet for easy positioning and levelling
- Earthing preset
- Ventilation and exhaust on the top of the cabinet (DN 100 mm connection)
- Ventilation and power supply closure via heat sensor
- Height-adjustable shelves (at regular 32 mm intervals)

### Internal configuration:

- 3 painted sheet metal shelves;
- 1 steel grid floor

CODE	DESCRIPTION	DIMENSIONS	SHELVES
419 004 595	Lithium battery safety cabinet w/shelves	External 120 x 59.5 x h 196 cm • 111.6 x 48.3 x h 160.30 cm	4

Pictures indicated in this catalogue are representative and not binding for the supplier in terms of layout and colours. They may be subject to changes by the supplier without prior notice.

# SAFETY CABINET FOR LITHIUM BATTERY STORAGE AND CHARGING WITH FEET



## MANUFACTURED IN COMPLIANCE WITH STANDARD DIN EN 1363-1

For charging lithium batteries; great attention is paid to fire protection. This cabinet is equipped with important safety devices; the fire hazard posed by these batteries can be reduced to a minimum, thus increasing safety in the company.

### FEATURES

- Preventive alarm in case of damage
- Compliance with all relevant safety rules relating to charging lithium batteries
- MPA certified fire resistance for up to 60 minutes inside-to-outside, in compliance with DIN EN 1363-1
- Fire resistant, non-flammable construction
- Special fire protection gasket that guarantees perfect sealing
- Low smoke density closure system
- Transportable for easy positioning in the place of use
- Two-leaf doors, lockable
- Orange door painting, to RAL 2004; grey body, RAL 7035
- Fan extraction of heat developed during charging operations
- Power supply through multi-socket (3500 W, 16 A)
- Power failure when opening doors
- Interruption of charging operations in the event of malfunction
- Automatic closure of the ventilation grids.
- Steel feet to allow handling by pallet truck. The feet allow easier handling and also to stack more cabinets.



### OPTIONALS:

- Metal shelving for practical positioning of 2 cabinets
- Internal shelf: doubles the surface and allows a better use of the internal space
- Wheel kit: for easy and quick handling (even in the event of movement required by an emergency)

CODE	DESCRIPTION	DIMENSIONS
419 004 888	Safety cabinet feet with for lithium battery storage and charging	Outside: 80 x 66 x h 62 cm Inside: 73 x 53 x h 45 cm



Pictures indicated in this catalogue are representative and not binding for the supplier in terms of layout and colours. They may be subject to changes by the supplier without prior notice.



## CONTAINER FOR LITHIUM BATTERIES



ON REQUEST

Fire-resistant REI/EI container suitable for containing used or new lithium batteries, according to the indications provided by the manufacturers.  
The containers will be equipped with air conditioning systems to keep the temperature within the limits imposed by manufacturers for correct storage.  
Containers may be fitted with cut-off switches to prevent the spread of fires.  
Each container will be made to measure and on a case-by-case basis, based on storage needs and the indications provided by the manufacturers of each battery.

DESCRIPTION	DIMENSIONS
Container for storage of lithium batteries	Tailor-made product

## APPROVED STEEL DRUM FOR LITHIUM BATTERIES



Galvanised steel drum, equipped with tie cover and pressure relief valve, in case of damage to the drum. Designed for transporting and storing lithium batteries UN 3480 and UN 3090 of 0.5 – 5 kg. Approved container for solid dangerous goods with a maximum weight of 60 kg. For fire protection, spent batteries must be stored and transported in combination with the appropriate packaging material: vermiculite. All containers are supplied with a PE bag.

CODE	DESCRIPTION	CAPACITY
419 004 600	Approved steel drum for lithium batteries • 38 x h 66 cm	60 L

Pictures indicated in this catalogue are representative and not binding for the supplier in terms of layout and colours. They may be subject to changes by the supplier without prior notice.

# CONTAINERS FOR STORAGE AND TRANSPORT of LITHIUM BATTERIES



419 004 597 - 419 004 598



419 004 861 - 419 004 862



## POLYETHYLENE

HDPE polyethylene stackable container, for transporting and storing lithium batteries. Approved UN container for solid dangerous goods (classified in packing group II and III). For fire protection, spent batteries must be stored and transported in combination with the appropriate packaging material: vermiculite. All containers are supplied with a cover, fastening straps and PE bag. Containers 419 004 861 and 419 004 862 are equipped with protective and stackable pillows.

CODE	DESCRIPTION	DIMENSIONS	CAPACITY
419 004 597	Polyethylene container for lithium batteries	External 120 x 80 x h 40 cm Internal 111.5 x 71.5 x h 24.5 cm	195 L
419 004 598	Polyethylene container for lithium batteries	External 120 x 100 x h 76 cm Internal 112 x 92 x h 60 cm	610 L
419 004 861	Container for transporting and storing lithium batteries with internal packaging (2 pillows)	External 40 x 30 x h 21.5 cm Internal 30 x 19 x h 9 cm	10 kg <b>new</b>
419 004 862	Container for transporting and storing lithium batteries with internal packaging (3 pillows)	External 40 x 30 x h 34 cm Internal 30 x 19 x h 21.5 cm	12 kg <b>new</b>
419 004 887	Protective pillow for lithium battery containers code 419004861 and 419004862		Box: 3 pcs <b>new</b>



419 004 887

## STEEL

Galvanized steel container, equipped with stackable closing buckles, designed for transporting and storing lithium batteries. Approved UN container for solid dangerous goods (classified in packing group II and III). For fire protection, spent batteries must be stored and transported in combination with the appropriate packaging material: vermiculite. All containers are supplied with a PE bag.

CODE	DESCRIPTION	DIMENSIONS	CAPACITY
419 004 599	Steel container for lithium batteries	External 71.5 x 71.5 x h 58 cm Internal 58 x 58 x h 39	120 L

Pictures indicated in this catalogue are representative and not binding for the supplier in terms of layout and colours. They may be subject to changes by the supplier without prior notice.



**CARDBOARD**

UN approved cardboard box for transportation of goods.  
Lithium batteries can be inserted into the box.  
Maximum weight allowed within the box: 14 kg/each Includes a PE bag.

CODE	DESCRIPTION	DIMENSIONS	CAPACITY
419 004 943	4GV/X14/S Box	360 x 360 x 340 mm	Box: 25 boxes

**ABSORBENT FOR STORAGE AND TRANSPORT OF LITHIUM BATTERIES**



Mineral-based absorbent powder used in combination with different packaging for transporting lithium batteries in ADR.

CODE	DESCRIPTION	CAPACITY
402 004 601	Vermiculite - 100 litre bag	-
402 004 619	Vermiculite - 400 kg box	Box: 40 x 100 litre bags

**HYDROFLUORIC ACID NEUTRALISER**



Hydrofluoric acid neutralising powder with colour change to indicate when the acid spill has been neutralised and is therefore ready to be removed. Greater neutralizing capacity compared to neutralizing liquids.  
Ideal in case of accidental spills due to rupture of lithium batteries.

CODE	DESCRIPTION	PACKAGING
404 004 617	Hydrofluoric Acid Neutraliser	4.5 kg bag



Pictures indicated in this catalogue are representative and not binding for the supplier in terms of layout and colours. They may be subject to changes by the supplier without prior notice.







**AIRBANK srl**

Via Luigi Bay • 29121 Piacenza

Tel. +39 0523 763134 • Fax +39 0523 763144

info@airbank.it • [www.airbank.it](http://www.airbank.it)

